

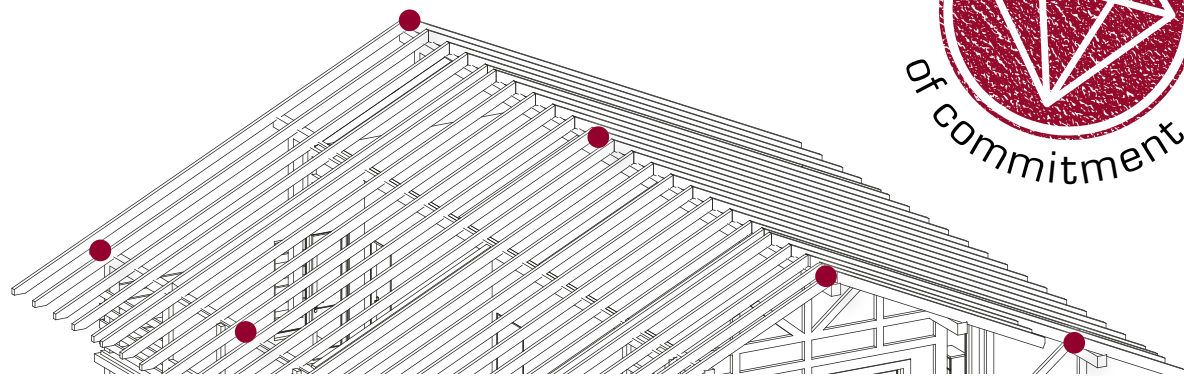

# TECHNICAL GUIDE

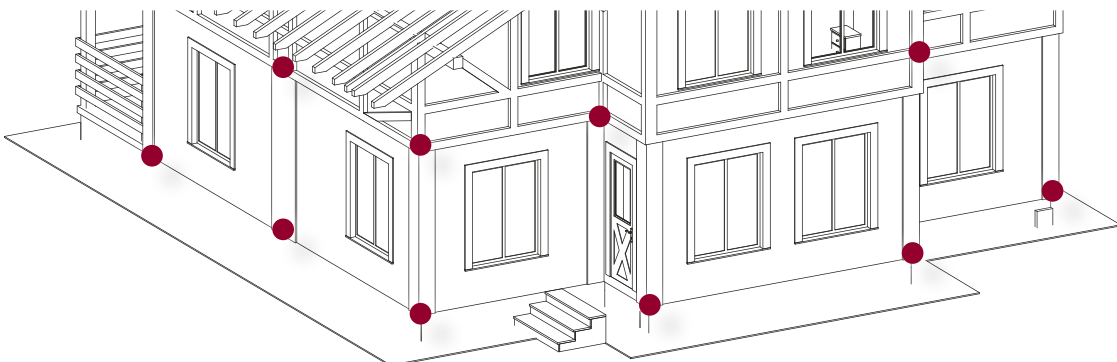

# THE CULLEN CONNECTION

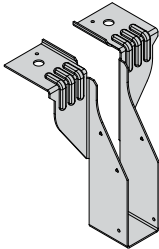
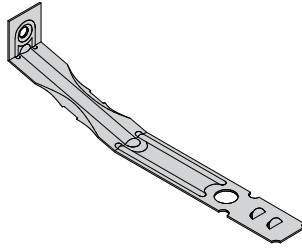
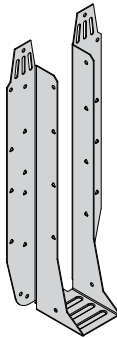

	<b>Page</b>
<b>Information &amp; Services:</b>	
	Company Profile & Services 4 - 5
	General Guidelines 6 - 7
	Fixings for Cullen Connectors 8 - 10
	Eurocode 5 11
<b>Timber To Masonry Connectors:</b>	
	Masonry Hanger Overview 12 - 13
	JHI Masonry Joist Hanger 14 - 15
	SB-JHIR Safe Build Masonry Joist Hanger 16 - 17
	RB-JHI Rapid Build Masonry Joist Hanger 18 - 19
	FMHI Flexible Masonry Hanger 20 - 22
	M-STD/M-RTN Very High Load Masonry Hanger 23
	VSM Variable Skew Masonry Hanger 24 - 25
	RA RANGE Restraint Angle Range 26 - 29
	HV-GR Hi-Vis Gripper 30 - 31
<b>Timber Frame:</b>	
	Timber Frame Overview 32
	ST-PFS/ST-PFS-M Timber Frame Holding Down Strap 33
	SP Sole Plate Anchor 34
	IR-CLIP Insulation Retaining Clip 35
	AWS Acoustic Wall Strap 36
	PWS Party Wall Strap 37
	PSTS Paslode Structural Screw (Open Panel Connection) 38
	Disproportionate Collapse Product Overview 39
	RD-DCR Disproportionate Collapse Restraint 40
	RD-HDCR Heavy Disproportionate Collapse Restraint 41
	RD-CDCR Corner Disproportionate Collapse Restraint 42
	Timber Frame Wall Ties Differential Movement 43
	FT Timber Frame / SIPs Wall Tie 44
	HMT High Movement Timber Frame Wall Tie 45
<b>EWP Connectors:</b>	
	EWP Timber Hanger Overview 46 - 47
	At A Glance UH & HUH Quick Reference Guides 48
	UH Universal Hanger (I-Joist Applications) 49 - 56
	UH Universal Hanger (Open Web Applications) 57 - 62
	FFI Face Fix I-Joist Hanger 63 - 66
	HUH Heavy Universal Hanger (I-Joist Applications) 67 - 70
	HUH Heavy Universal Hanger (Open Web Applications) 71 - 77
	<b>Steel Connections</b> 78 - 79
	MH RANGE Multi Hanger 80 - 81
	KM Mini Hanger 82
	FTHI Flexible Timber Hanger 83
	VS Variable Skewed Timber Hanger 84 - 85
	VRC Variable Ridge Connector 86 - 87
	ACE Adjustable Connector Eaves 88
	45L/R Face Fix 45° Hanger 89
	UZ-Clip Noggin Support 90 - 91
	I-Clip Multiple I-Joist Connector 92 - 93
	OW-Clip Multiple Joist Connector 94 - 95
	PSTS Paslode Structural Screw (Multiple Connections) 96 - 100
	SHI Service Hole I-Joist 101

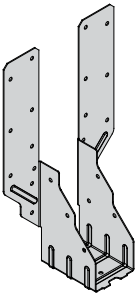
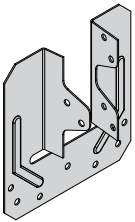
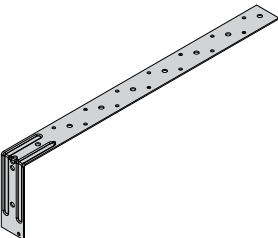
	<b>Page</b>
<b>Solid Timber/Roof Truss:</b>	
	
<b>Solid Timber/Roof Truss Overview</b>	102 - 103
<b>KM</b> Mini Hanger	104
<b>TM</b> Midi Shoe	105
<b>TS</b> Truss Shoe	106
<b>HMH</b> Heavy Multi Hanger	107
<b>HGG</b> Heavy Girder To Girder	108
<b>VHGG</b> Very Heavy Girder To Girder	109
<b>KH</b> Kwiki Hanger Standard Leg	110
<b>KHL</b> Kwiki Hanger Long Leg	111
<b>MH RANGE</b> Multi Hanger	112 - 113
<b>FTHI</b> Flexible Timber Hanger	114
<b>LAB</b> Angle Bracket	115
<b>SA-45</b> Skewed Angle 45° Hanger	116
<b>45L/R</b> Face Fix 45° Hanger	117
<b>VS</b> Variable Skewed Timber Hanger	118 - 119
<b>NP</b> Nail Plate	120
<b>SB</b> Support Bracket	121
<b>Truss To Wall Plate:</b>	
	
<b>Wallplate Connection Overview</b>	122
<b>TC</b> Truss Clip	123
<b>TA</b> Truss Anchor	124
<b>TA-1</b> Framing Anchor	125
<b>SS</b> Slide Shoe	126
<b>FAS</b> Framing Anchor	127
<b>Restraint Straps:</b>	
	
<b>Restraint Straps Overview</b>	128
<b>Restraint Straps (Domestic Roofs)</b>	129 - 131
<b>Restraint Straps (Domestic Floors)</b>	132 - 133
<b>VRS</b> Vertical Restraint Strap	134
<b>RST</b> Restraint Strap Twist	135
<b>PFS</b> Pre Formed Strap	136
<b>PS RANGE</b> Pre Formed Strap	137
<b>LDGS</b> Light Duty Galvanised Strap	138
<b>HDGS</b> Heavy Duty Galvanised Strap	139
<b>ST-ST-PFS</b> Stainless Steel Pre Formed Strap	140
<b>WBR</b> Window Bracket	141
<b>Notes</b>	142 - 143
<b>Product Range Index</b>	144

# Company Profile & Services



## ITW Construction Products

ITW Construction Products is one of seven major divisions of the Illinois Tool Works family, innovating, designing and manufacturing advanced industrial technology.

With five brands all at the forefront of technology and enterprise for their respective markets, ITW Construction Products are committed to providing advanced trade solutions for professional users.

### A leader in technology, research and development

ITW Construction Products are known for their problem solving nature, and as such always remain a leader in technology, research and development; a trait that enhances our interaction and relationship with our customer and generates increased productivity for our end users.



## Part of a Global Company: ITW Inc.

ITW – We are everywhere. With over 12,000 active patents ITW's products and solutions are at work all over the world, in deep-sea oil rigs, aerospace technology, bridges and wind turbines, supporting commercial buildings, healthcare, the spaces in which we live and work, the construction of those spaces, the cars we drive, and the mobile devices we rely on. We are never, whether we know it or not, more than a few steps from an innovative ITW solution.

We are committed to operational excellence and systematic new product development that helps our customers create the products and services that make our lives better.

**You are never more than a few steps from an innovative ITW solution**



## Cullen

Since 1977 Cullen has been a brand name synonymous with innovation, quality and customer service within the building industry.

**A brand synonymous with innovation, quality and customer service**

Becoming a part of ITW Construction Products in 2008, Cullen has benefitted from the expertise and resources of a global corporation allowing them to grow, invent and create more than before.

Designing and manufacturing a complete range of timber engineering connectors, Cullen is at the forefront of market trends, ideas and needs.

Chosen for their highest quality and European compliance of both EN792 – 13 and Eurocode 5, our timber engineering solutions will become a mainstay of your most valued business assets.

**Our Engineered Wood Product Brands:**



**ALPINE**

**GANG-NAIL**

**Our Construction Fixings Brands:**



## Innovation

At Cullen we follow a customer focused approach to new product development which allows us to research and interpret the true needs of our customers and their industry. Our product development begins on site, not in a lab.

Thanks to our dedicated focus on innovation, Cullen adds new products to its offering which are true problem solvers for the industry.

## Product development begins on site, not in a lab

Our state of the art research facility in Glenrothes, Scotland includes a test rig, timber conditioning chamber and computer controlled turret press for prototype work.



## Cullen App

The Cullen App was developed with the end user in mind showing, through detailed animations, how our products are correctly fixed in a multitude of different connection details. This App can be used by Building Inspectors, Site Managers, Construction Directors, anyone who needs to check for correct installation.



Available now for download on both Apple & Android. Check it out on Google Play and search Cullen Floor.



## Qualified Technical Support

You can be confident with Cullen that you are fully supported by a highly qualified technical team.

With almost 40 years of experience, our technical experts are ready to offer advice in timber engineering related matters.

Available Monday to Friday from 8.30am – 5:00pm.

**UK: 01592 777570**  
**cullentechnical@itwcp.com**

Our skilled professionals play a leading role in the industry's representative bodies finding solutions to future challenges.

## Customer Support

Our dedicated team of customer service advisors are always available to take your calls.

They can assist you with:

- Processing your orders
- Providing pricing and delivery information
- Answering questions and queries
- Putting you in touch with the correct member of our organization

Available Monday to Friday from 8:30am – 5:00pm.

**UK: 01592 771132**  
**orders@itwcp.com**

Get in touch with us today to see how we can assist you.

# General Guidelines



## Technical Information

The technical information contained in this brochure is correct at the time of updating, February 2017. ITW Construction Products reserve the right to amend, change or update the technical information without giving prior notice. For current product updates and technical information, visit our website [www.itwcp.com](http://www.itwcp.com).

The contents of this brochure and the latest product updates posted on the website supersede all previous Cullen publications including all brochures, installation guides, manuals and information sheets.

If you would like to receive technical bulletin updates and industry news, or would like to be informed of new Cullen products, please visit our website.

All safe working loads are derived from tests and are underwritten by ITW Construction Products. All characteristic values are derived from tests carried out by independent accredited test labs (unless otherwise stated). Cullen European Technical Approvals (ETA) have been submitted for approval using British Board of Agrément (BBA) as the approved notified body.

## General Installation Information

- Proper product installation and construction practices must be followed at all times
- Timber members and Engineered Wood Products may split when nailed; this may reduce their safe working load/characteristic capacity
- To achieve the safe working loads/characteristic capacities published all specified nails and fastenings must be used and installed as per the instructions set out in this brochure
- Failure to follow proper nailing procedures and instructions will reduce the safe working loads/characteristic capacities
- **Only bend Cullen connectors when directed to by the appropriate Cullen installation guide, and when necessary “only bend once”**

## Design Information

- The integrity of the building or structure must be validated by a suitably qualified Building Designer or Engineer (the “Designer”)
- The Designer is responsible for determining that the appropriate connector and/or hanger has been selected
- Location and spacing of straps must be specified by the Designer
- When selecting the appropriate connector and/or hanger, consideration must be given to the safe working loads or characteristic capacities required, bearing support and connection details within the building or structure
- **For all Engineered Wood Products (EWP), ITW Construction Products recommends the hanger height be at least 60% of the joist height for lateral stability**
- Any bespoke Cullen product designed by ITW Construction Products but manufactured by another (unless directed to by ITW Construction Products) will not be covered under ITW Construction Product’s warranty
- ITW Construction Products reserve the right to (i) change the design specifications and applications of any connector/hanger, or (ii) withdraw any connector or hanger without giving prior notice

**NB.** Any modification to any Cullen custom-made or manufactured connector and/or hanger product will void any warranty given by Cullen in relation to that particular connector and/or hanger product.

## Galvanised Protection

**Z275** galvanised coating is the minimum corrosion protection recommended for Service Class 2 applications (BS EN1995-1-1 Table 4.1 Examples of minimum specification for material protection against corrosion for fasteners).

**Z600** galvanised coating gives a greater corrosion protection for use with masonry applications (BS EN845-1 Annex A1, Table A.1 Materials and corrosion protection systems)

## Service Classes (BS EN1995-1-1 section 2.3.1.3)

- (1) P Structures shall be assigned to one of the service classes given below.

NOTE: The service class system is mainly aimed at assigning strength values and for calculating deformations under defined environmental conditions.

NOTE: Information on the assignment of structures to service classes given in (2)P, (3)P and 4(P) may be given in the National annex.

- (2) P Service class 1 is characterised by a moisture content in the materials corresponding to a temperature of 20°C and the relative humidity of the surrounding air only exceeding 65% for a few weeks per year.

NOTE: In service class 1 the average moisture content in most softwoods will not exceed 12%.

- (3) P Service class 2 is characterised by a moisture content in the materials corresponding to a temperature of 20°C and the relative humidity of the surrounding air only exceeding 85% for a few weeks per year.

NOTE: In service class 2 the average moisture content in most softwoods will not exceed 20%.

- (4) P Service class 3 is characterised by climatic conditions leading to higher moisture contents than in service class 2.

UK National annex to BS EN1995-1-1 states the following service classes for these applications:

Type of Construction	Service Class
Cold roofs	2
Warm roofs	1
Intermediate floors	1
Ground floors	2
Timber-frame walls, internal and party walls	1
Timber-frame walls, external walls	2
External uses where member is protected from direct wetting	2
External uses, fully exposed	3

# Fixings For Cullen Connectors

## Fixings for Cullen

This section sets out to simplify the specification of ITW Construction Products fasteners and fastening systems for use with Cullen timber engineered connectors. These fasteners have been tested in conjunction with the Cullen connectors, meaning that **published design values are underwritten by ITW Construction Products** if used together.

## Fastening Cullen Connectors

To achieve the safe working loads / characteristic capacities published in this Cullen Technical Guide and specified by roof truss or floor joist design software, connectors must be installed using the correct number and type of fasteners.

The fasteners in this section have been assessed and qualified as suitable for use with Cullen connectors. **All published values are underwritten by ITW Construction Products.** Using an unqualified or alternative fastener could result in a reduced connector capacity and the design values not being underwritten.

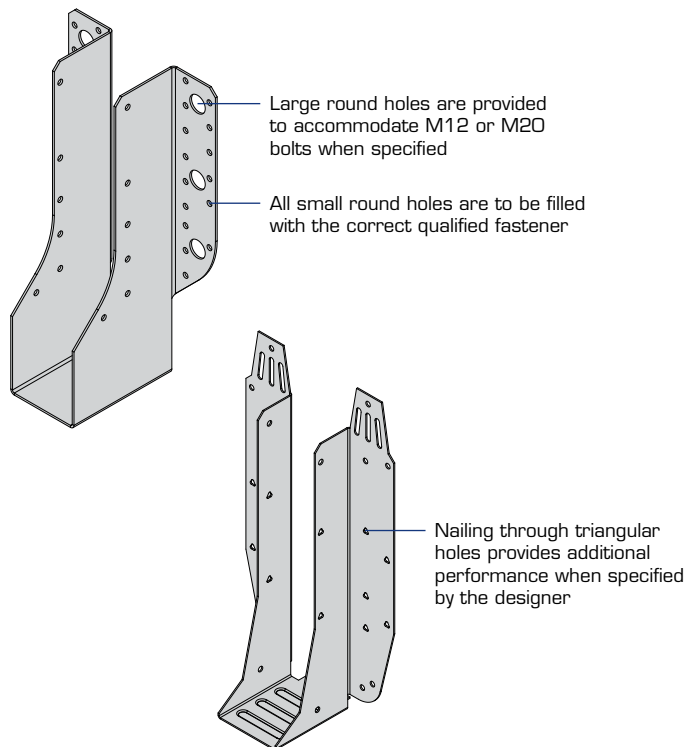

## PASLODE GAS POSITIVE PLACEMENT NAILER



Product Code	Description
014095	PPN35Ci Li-ion Gas Positive Placement Nailer



**Paslode PPN35Ci Li-ion Gas Positive Placement Nailer**  
Drives ETA approved, CE compliant hardened twist nails through connectors and hangers into solid wood beams.



### Nail Specification

Product Code:	141189	141185
Box Qty:	1,250	2,500
Shank Type:	Square Twist Hardened	
Shank Diameter:	3.4mm	
Length:	35mm	
Head Diameter:	7.0mm	
Average Profile Diameter:	3.7mm	
Finish:	12µm Electro Galv	



## PASLODE PNEUMATIC POSITIVE PLACEMENT NAILER



Product Code	Description
500855	F250S PP Pneumatic Positive Placement Nailer



**Paslode F250S PP Pneumatic Positive Placement Nailer**  
Drives ETA approved, CE compliant hardened twist nails through connectors and hangers into solid wood beams.



### Nail Specification

Product Code:	140588	
Box Qty:	3,000	
Shank Type:	Square Twist Hardened	
Shank Diameter:	3.4mm	
Length:	35mm	
Head Diameter:	7.0mm	
Average Profile Diameter:	3.7mm	
Finish:	12µm Electro Galv	





# Fixings For Cullen Connectors



## LOOSE FASTENERS

### 3.4 x 35mm Electro Galvanised Square Twist Nails



Product Code:	547389
Box Qty:	500
Shank Type:	Square Twist
Shank Diameter:	3.4mm
Length:	35mm
Head Diameter:	8.0mm
Average Profile Diameter:	3.7mm
Finish:	12µm Electro Galv

### Pozidrive S/Steel and TX20 Galvanised Screws

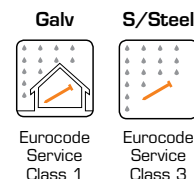

Product Code:	114386	150314
Box Qty:	200	200
Shank Type:	Sscrew Thread	Sscrew Thread
Shank Diameter:	3.0mm	3.0mm
Length:	25mm	25mm
Head Diameter:	9.5mm	9.5mm
Average Profile Diameter:	5.0mm	5.0mm
Finish:	Stainless Steel A2	5µm Electro Galv

### 3.35 x 50mm Stainless Steel Annular Ring Shank Nails



Product Code:	547297
Box Qty:	250
Shank Type:	Ring Shank
Shank Diameter:	3.35mm
Length:	50mm
Head Diameter:	-
Average Profile Diameter:	-
Finish:	Stainless Steel

### Paslode Structural Timber Screws



Product Code:	See page 94	See page 94
Box Qty:	100	100
Outer Thread Shank Diameter:	6.5mm	8.0mm
Plain Shank Diameter:	4.8mm	5.85mm
Length:	35 - 250mm	65 - 135mm
Head Diameter:	11.5mm	16mm
Finish:	5µm Electro Galv	5µm Electro Galv

## SPIT POWDER ACTUATED TOOL SYSTEM



### SPIT P370 Cordless Powder Actuated Tool For fixing to steel of thickness 5mm to 10mm.



Product Code	Description
011071	P370 Powder Actuated Tool with Magazine (includes Single Shot Adaptor)

### SC9 Collated Drive Pins

Product Code:	011340
Box Qty:	500
Shank Type:	Drive Pin
Shank Diameter:	4mm
Length:	15mm
Head Diameter:	9.0mm
Average Profile Diameter:	-
Finish:	7µm Electro Galv



# Fixings For Cullen Connectors



## BOLTS

### M12 BOLT

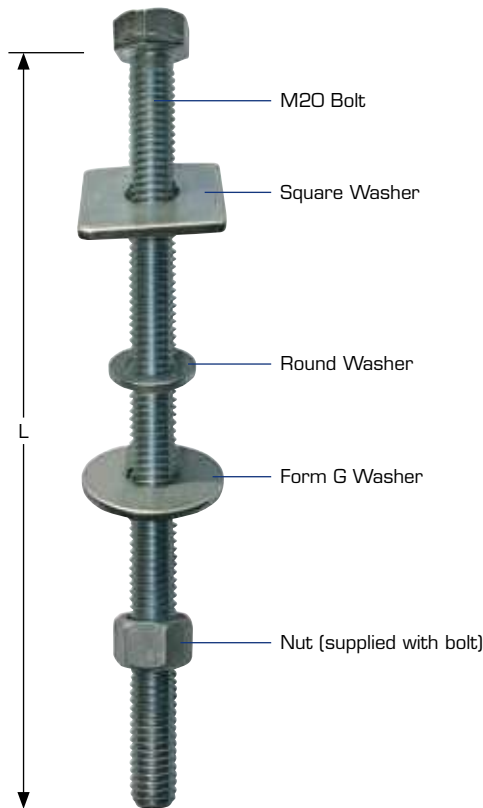

#### M12 Bolt General Specification

Shank Type:	Threaded
Shank Diameter:	M12
Head Diameter A/F:	19.0mm
Head Thickness:	7.5mm
Grade:	8.8
Finish:	>5µm Electro Galv

#### M12 Bolt Lengths

Product Code	Bolt Length (L) (mm)	Description
M-12-130-HRH-FULL-THREAD	130	M12 x 130mm HRH Bolt (full thread to suit 100 - 130mm bolt length) & Nut
M-12-180-HRH-FULL-THREAD	180	M12 x 180mm HRH Bolt (full thread to suit 140 - 180mm bolt length) & Nut
M-12-240-HRH-FULL-THREAD	240	M12 x 240mm HRH Bolt (full thread to suit 200 - 240mm bolt length) & Nut
M-12-300-HRH-FULL-THREAD	300	M12 x 300mm HRH Bolt (full thread to suit 260 - 300mm bolt length) & Nut

#### M12 Nuts & Washers

Product Code	Diameter / Length (mm)	Thickness (mm)	Description
M-12-SQUARE	50 x 50	3.0	M12 Square Washer
M-12-ROUND	24	2.5	M12 Round Washer
M-12-FORM-G	36	3.0	M12 Form G Washer
M-12-NUT	19 A/F	10.0	M12 Nut

### M20 BOLT

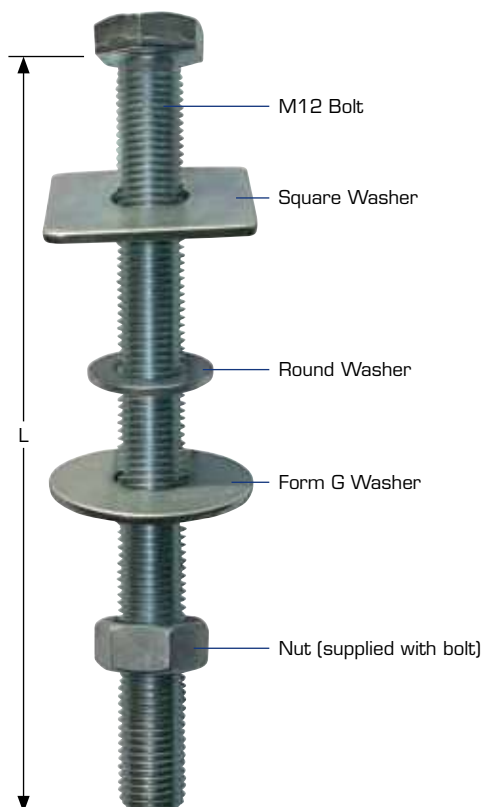

#### M20 Bolt General Specification

Shank Type:	Threaded
Shank Diameter:	M20
Head Diameter A/F:	30.0mm
Head Thickness:	12.5mm
Grade:	8.8
Finish:	>5µm Electro Galv

#### M20 Bolt Lengths

Product Code	Bolt Length (L) (mm)	Description
M-20-130-HRH-FULL-THREAD	130	M20 x 130mm HRH Bolt (full thread to suit 100 - 130mm bolt length) & Nut
M-20-180-HRH-FULL-THREAD	180	M20 x 180mm HRH Bolt (full thread to suit 140 - 180mm bolt length) & Nut
M-20-240-HRH-FULL-THREAD	240	M20 x 240mm HRH Bolt (full thread to suit 200 - 240mm bolt length) & Nut

#### M20 Nuts & Washers

Product Code	Diameter / Length (mm)	Thickness (mm)	Description
M-20-SQUARE	50 x 50	3.0	M20 Square Washer
M-20-ROUND	36	2.5	M20 Round Washer
M-20-FORM-G	60	5.0	M20 Form G Washer
M-20-NUT	30 A/F	16.0	M20 Nut

## Eurocode 5 (BS EN1995-1-1)

Presently timber designs in the UK can be carried out using national standards BS 5268 part 2 & 3 or using BS EN1995-1-1 (Eurocode 5).

Eurocode 5 is the harmonised European Standard covering the design of timber structures.

The purpose of the Eurocodes is to establish a common set of standards for the design of buildings across all European member states, although each member can have its own National Annex which is used in conjunction with the Eurocodes for design.

## Technical Approvals

All timber-to-timber hangers are tested to meet the requirements of ETAG O15 Guideline for European Technical Approval of three-dimensional nailing plates, which allows the hangers to be submitted for a European Technical Assessment which once issued enables the products to be CE Marked.

All timber-to-masonry products (hangers, straps and wall ties) are tested to meet the requirements of BS EN845-1 enabling them to be CE marked.

Fasteners for timber structures (nails, screw and bolts) are tested to meet the requirements of BS EN14592 enabling them to be CE marked.

## Load Tables

Presently in the UK timber design can be carried out to BS 5268-2:2006 which is based on permissible stress design, or BS EN1995-1-1:2004+A1:2014 (EC5) which is based on limit state design. The following brochure pages will state two different sets of values:

- Safe Workings Loads – permissible values calculated to BS 5268-2:2002 and have factors of safety applied to them e.g. Long Term-2.4, Medium Term-2.1 and Short Term-2.0
- Characteristic capacity of hanger is based on ultimate limit states and is unfactored

### Example Load Data: UH Hanger Standard Installation - I-Joist Header without Backer Block

Hanger Depth (mm) (Depth Dependent Only)	Fixings (3.4x35mm)			Safe Working Loads (kN)				Characteristic Capacity (kN)		
	Header		Incoming	Uplift - Short Term	Uplift - Long Term	I-Joist Header		Uplift	I-Joist Header	
	Face	Top				Long Term			Solid Flange	LVL Flange
195	8	2	2	2.10	1.75	4.83	4.83	3.97	11.13	12.94
220	8	2	4	2.10	1.75	4.83	4.83	3.97	11.13	12.94
235	8	2	4	2.10	1.75	4.50	4.63	3.97	11.89	11.79
300	8	2	4	2.10	1.75	4.50	4.63	3.97	11.89	11.79

## What does this mean for our products?

In addition to publishing safe working loads that have already been factored down, characteristic values for each product will be published. The characteristic value is the lower 5th percentile value obtained from test results.

A series of modification factors must be applied to the characteristic value to determine the Design Value.

## Timber to Timber Connectors

$$\text{Design Value} = (F_k \times K_{\text{mod}}) / Y_m$$

$F_k$  = Characteristic value

$K_{\text{mod}}$  = Modification factor for duration of load and moisture content (EN1995-1-1 table 3.1)

$Y_m$  = Partial factors for material properties and resistance (1.3 for connections – EN1995-1-1 table 2.3)

## Timber to Masonry Connectors

$$\text{Design Value} = F_k / Y_m$$

$F_k$  = Characteristic value

$Y_m$  = Partial factors for material properties and resistance (1.5 for masonry – EN845-1)

# Masonry Hanger Overview



## 3 COURSES OF MASONRY ABOVE (675MM)

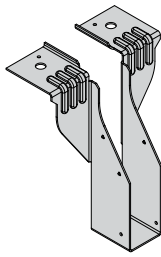

**JHI**  
Pages 14 - 15

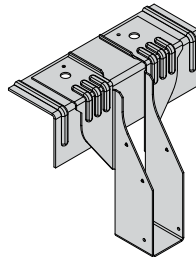

**RB-JHI**  
Pages 18 - 19

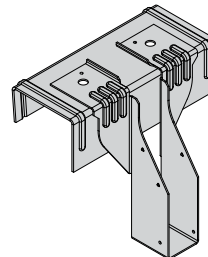

**RB-JHIR**  
Pages 18 - 19

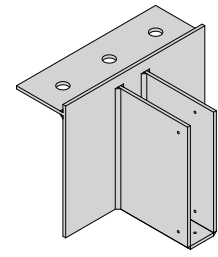

**MASONRY-STD**  
Page 23

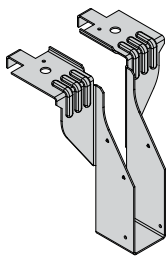

**JHIR**  
Pages 14 - 15

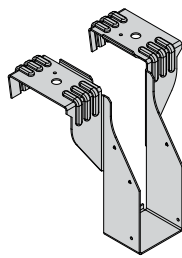

**SB-JHIR**  
Pages 16 - 17

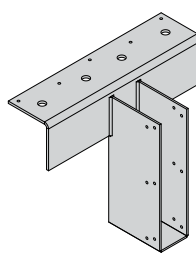

**FMHI**  
Pages 20 - 22

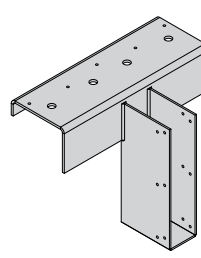

**FMHIR**  
Pages 20 - 22

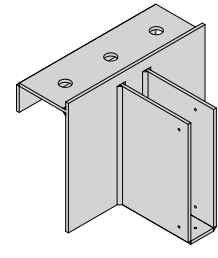

**MASONRY-RTN**  
Page 23

**STANDARD**

**HIGH LOAD**

**VERY HIGH LOAD**

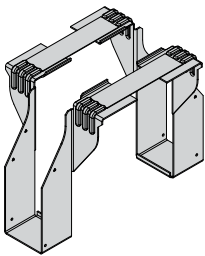

**JHIST**  
Pages 14 - 15

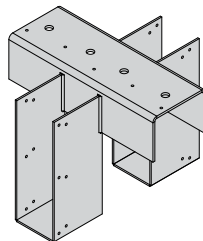

**FMHIST**  
Pages 20 - 22

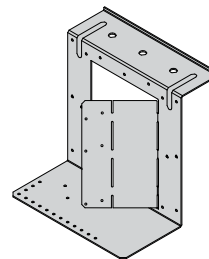

**VSM**  
Pages 24 - 25

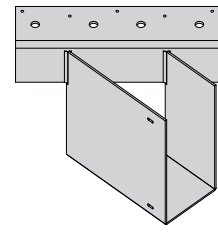

**FMHIS**  
Pages 20 - 22

**STRADDLE**

**SKewed**

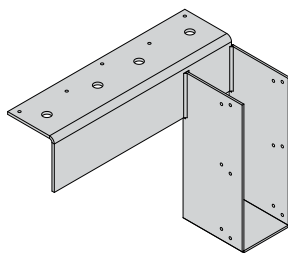

**FMHIO**  
Pages 20 - 22

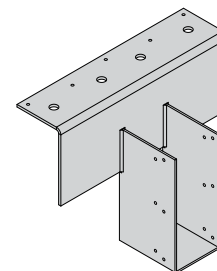

**FMHID**  
Pages 20 - 22

**OFFSET**

**DROPPED**

# Masonry Hanger Overview



## NO REQUIREMENT FOR MASONRY ABOVE

Unless specified to achieve higher load carrying capacity

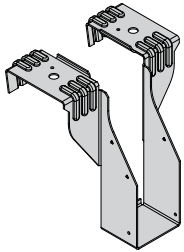

**SB-JHIR**  
Pages 16 - 17

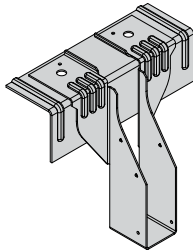

**RB-JHI**  
Pages 18 - 19

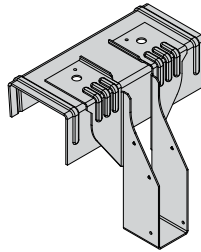

**RB-JHIR**  
Pages 18 - 19

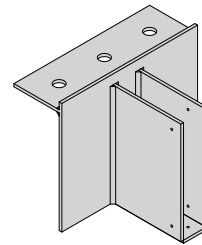

**MASONRY-STD**  
Page 23

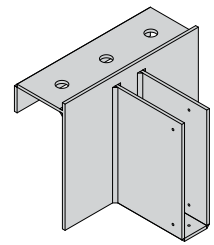

**MASONRY-RTN**  
Page 23

**STANDARD**

**HIGH LOAD**

**VERY HIGH LOAD**

FOR SKEWED HANGERS WITH LESS THAN 3 COURSES OF MASONRY ABOVE CONTACT CULLEN TECHNICAL

## RESTRAINT HANGERS

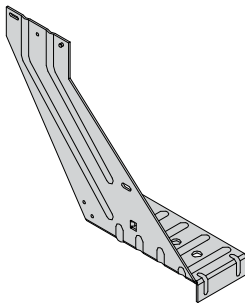

**RA**  
Pages 26 - 29

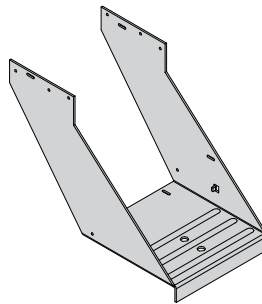

**HRAD**  
Pages 26 - 29

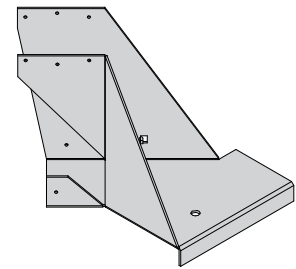

**RADS**  
Pages 26 - 29

**STANDARD**

**HIGH LOAD & >97MM WIDE**

**SKEWED**

## ANCILLARY PRODUCTS

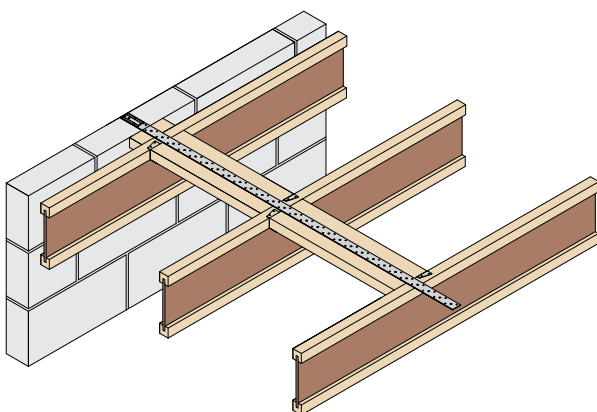

**Restraint Straps**  
Pages 132 - 133

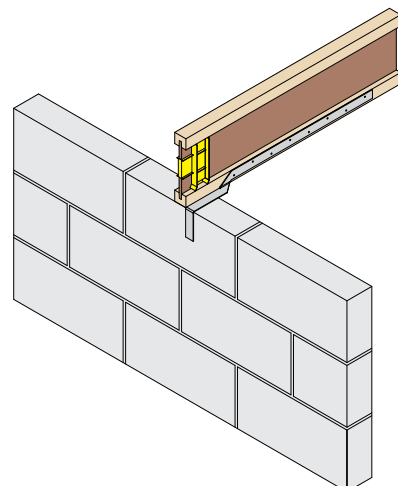

**I-Joist End Seal**  
Pages 30 - 31

## Masonry Joist Hanger

European Community Registered Design



The JHI hanger is a traditional timber to masonry hanger range designed for use with I-joists, open web & solid timber joists/trusses.

### Features & Benefits

- The same air leakage values of a wall with no protrusions, forming a major contribution towards Part L1 Building Regulations
- Approved and tested for use with H&H Thin Joint System (Contact Technical for approved installation guide)

### Material Specification

- Galvanised mild steel - Z600

### Fixings

Fixings required into incoming member only. No fixings required into masonry.

Code	Description	Box Qty
547389	3.4 x 35mm Square Twist Nails - LOOSE	500
141185	3.4 x 35mm Square Twist Nails - COLLATED*	2,500

\*For use with Paslode PPN35C

### Available Sizes

Hanger Width (W) (mm)	Hanger Depth (H) (mm)								
	150	175	195	225	240	250	300	350	400
39	JHI-39-150	JHI-39-175	JHI-39-195	JHI-39-225	JHI-39-240	JHI-39-250	JHI-39-300	JHI-39-350	JHI-39-400
46	JHI-46-150	JHI-46-175	JHI-46-195	JHI-46-225	JHI-46-240	JHI-46-250	JHI-46-300	JHI-46-350	JHI-46-400
50	JHI-50-150	JHI-50-175	JHI-50-195	JHI-50-225	JHI-50-240	JHI-50-250	JHI-50-300	JHI-50-350	JHI-50-400
55	-	-	-	JHI-55-225	JHI-55-240	-	JHI-55-300	-	-
61	-	-	JHI-61-195	JHI-61-225	JHI-61-240	-	JHI-61-300	JHI-61-350	JHI-61-400
65	JHI-65-150	JHI-65-175	JHI-65-195	JHI-65-225	JHI-65-240	JHI-65-250	JHI-65-300	JHI-65-350	JHI-65-400
72	-	-	JHI-72-195	JHI-72-225	JHI-72-240	-	JHI-72-300	JHI-72-350	JHI-72-400
75	JHI-75-150	JHI-75-175	JHI-75-195	JHI-75-225	JHI-75-240	JHI-75-250	JHI-75-300	JHI-75-350	JHI-75-400
78	-	-	JHI-78-195	JHI-78-225	JHI-78-240	JHI-78-250	JHI-78-300	JHI-78-350	JHI-78-400
92	JHI-92-150	JHI-92-175	JHI-92-195	JHI-92-225	JHI-92-240	JHI-92-250	JHI-92-300	JHI-92-350	JHI-92-400
100	JHI-100-150	JHI-100-175	JHI-100-195	JHI-100-225	JHI-100-240	JHI-100-250	JHI-100-300	JHI-100-350	JHI-100-400
110	-	-	-	JHI-110-225	JHI-110-240	-	JHI-110-300	-	-
122	-	-	JHI-122-195	JHI-122-225	JHI-122-240	-	JHI-122-300	JHI-122-350	JHI-122-400
125	-	-	JHI-125-195	JHI-125-225	JHI-125-240	JHI-125-250	JHI-125-300	JHI-125-350	JHI-125-400
130	-	-	JHI-130-195	JHI-130-225	JHI-130-240	-	JHI-130-300	JHI-130-350	-
138	-	-	JHI-138-195	JHI-138-225	JHI-138-240	JHI-138-250	JHI-138-300	JHI-138-350	JHI-138-400
144	-	-	JHI-144-195	JHI-144-225	JHI-144-240	-	JHI-144-300	JHI-144-350	JHI-144-400
150	-	-	JHI-150-195	JHI-150-225	JHI-150-240	JHI-150-250	JHI-150-300	JHI-150-350	JHI-150-400
156	-	-	-	JHI-156-225	JHI-156-240	-	-	-	-
183	-	-	JHI-183-195	JHI-183-225	JHI-183-240	-	JHI-183-300	JHI-183-350	JHI-183-400
198	-	-	JHI-198-195	JHI-198-225	JHI-198-240	JHI-198-250	JHI-198-300	JHI-198-350	JHI-198-400

### Dimensions (mm)

#### JHI - 39-138MM WIDE

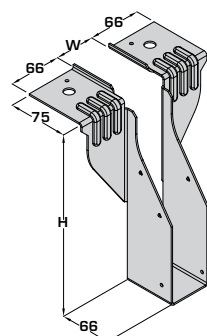

JHI-W-H  
Example: JHI-50-225

#### JHI - 144-198MM WIDE

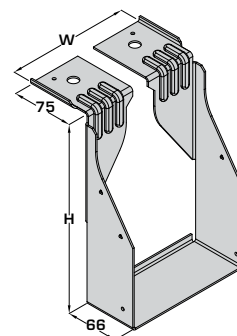

JHI-W-H  
Example: JHI-150-225

#### JHIR - RETURN

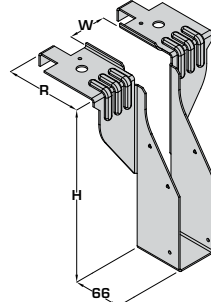

JHIR-W-H-R  
Example: JHIR-50-225-100  
(Returns available to suit 100 & 140mm wide block work)

#### JHIST - STRADDLE

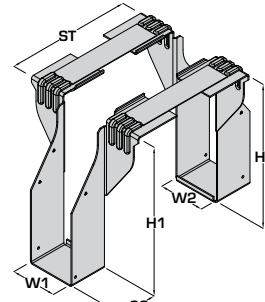

JHIST-W-H-ST or JHIST-W1-H1-ST-W2-H2  
Example: JHIST-50-225-100  
Example: JHIST-50-225-100-75-225

## Masonry Joist Hanger

### In Situ

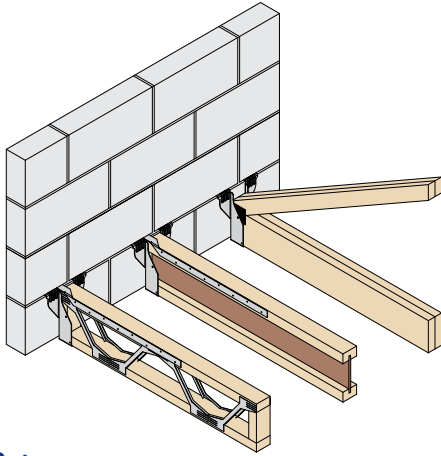

- Suitable for use with Open Web Joists, I-Joists and trusses
- Floor can be propped with acroprops and fully decked but must not be fully loaded until the masonry above has fully cured



- A minimum of **3 courses (675mm)** of masonry above is required for hanger to achieve loads stated
- The masonry above must be fully cured for **28 days** prior to loading the floor
- All hangers in this range do not provide restraint, therefore restraint straps may be required for joist applications (see pages 132 - 133)

### Load Data

Product Code	Masonry Above (Min 675mm)	Fixings (3.4 x 35mm)	Safe Working Loads (kN)					Characteristic Capacity (kN)				
			Uplift Short Term	Masonry Crushing Strength				Uplift	Masonry Crushing Strength			
				2.8N/mm <sup>2</sup>	3.5N/mm <sup>2</sup>	7.0N/mm <sup>2</sup>			2.8N/mm <sup>2</sup>	3.5N/mm <sup>2</sup>	7.0N/mm <sup>2</sup>	
				All widths	All widths	39 - 100mm wide	122 - 198mm wide		All widths	All widths	39 - 100mm wide	122 - 198mm wide
JHI JHIR JHIST	Yes	2	1.00	6.00	7.54	11.00	7.54	2.00*	11.17	13.97	23.04	13.97

### Enhanced Uplift

- Fixings into the incoming joist/truss are required to resist uplift
- Increased uplift figures can be achieved by nailing the additional triangular nail holes into the incoming member
- Web stiffeners required for I-Joists, 2No end blocks required for Open Web Joists & minimum bottom chord depth/vertical required for trusses

Fixings (3.4 x 35mm)	Safe Working Loads (kN)			Characteristic Capacity (kN)
	Incoming	Uplift - Short Term	Uplift - Long Term	
5	2.25	2.14	1.87	4.50

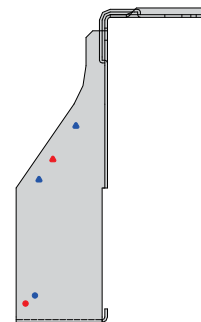

Hanger Depth (mm)	Min Timber Depth (mm)
150	84
175 - 195	122
225 - 240	172
250	195
300	235
350	300
400	350

### Incorrect Installation

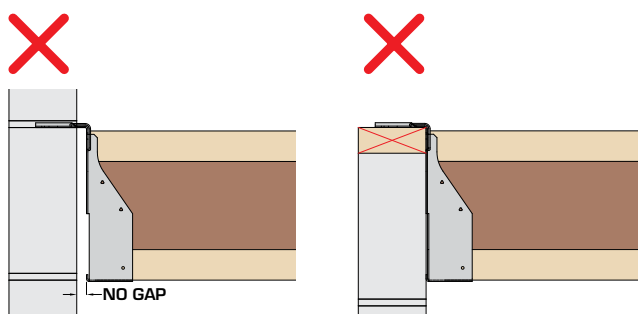

Do not install the hanger with a gap between the hanger and the face of the block work.

Do not install the hanger onto a timber wall plate.

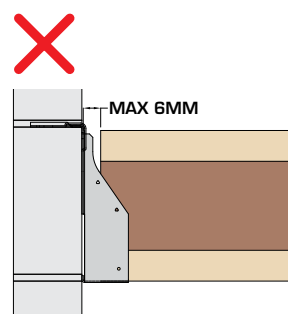

Do not install the hanger with a gap exceeding 6mm between the joist/truss and the hanger.

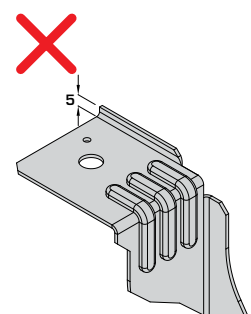

Do not flatten the 5mm upstands on the hanger top flanges. These are critical to the performance.

# SB-JHIR



## Safe Build Masonry Joist Hanger



**NEW**

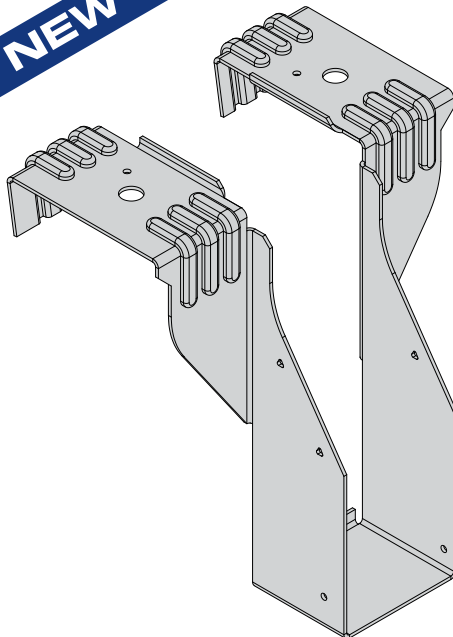

The **SB-JHIR** hanger is a new timber to masonry hanger range designed for use with I-Joists and open webs from masonry walls without the need for masonry above the top flange.

### Features & Benefits

- Requires no masonry above the hanger to achieve performance values stated
- Allows a safe working platform with no masonry above, reducing health and safety risks compared with traditional masonry hangers
- Supporting block work only needs to cure for 3 days instead of the standard 28 days for traditional masonry hangers, speeding up the build process

### Material Specification

- Galvanised mild steel - Z600

### Fixings

Fixings required into incoming member only. No fixings required into masonry.

Code	Description	Box Qty
547389	3.4 x 35mm Square Twist Nails - LOOSE	500
141185	3.4 x 35mm Square Twist Nails - COLLATED*	2,500

\*For use with Paslode PPN35Ci

### Available Sizes

Hanger Width (W) (mm)	Hanger Depth (H) (mm)
	225
46	SB-JHIR-46-225-100
50	SB-JHIR-50-225-100
61	SB-JHIR-61-225-100
65	SB-JHIR-65-225-100
72	SB-JHIR-72-225-100
75	SB-JHIR-75-225-100
92	SB-JHIR-92-225-100
100	SB-JHIR-100-225-100

### Dimensions (mm)

#### SB-JHIR-46-100MM WIDE

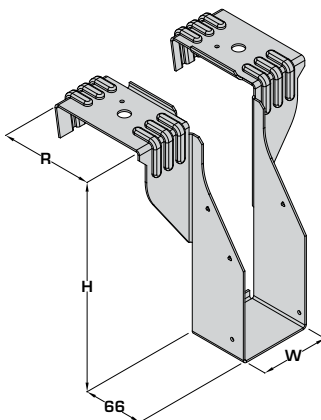

SB-JHIR-W-H-R

Example: SB-JHIR-50-225-100

(Return available to suit 100mm wide block work)



## Safe Build Masonry Joist Hanger

### In Situ

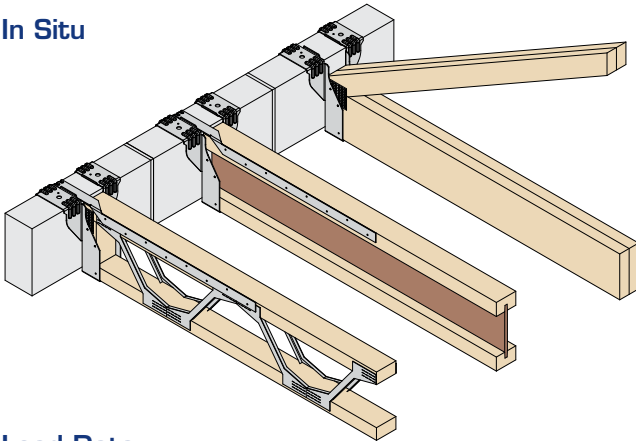

- Suitable for use with Open Web Joists, I-Joists and trusses
- No need for propping and allows safe working platform with no masonry above



- **No masonry** is required above the hanger
- The masonry supporting the hanger must be cured for **3 days** prior to loading the floor.
- The SB-JHIR does not provide restraint, therefore restraint straps may be required (see pages 132 - 133)

### Load Data

Hanger Type	Masonry Above (Min 675mm)	Fixings (3.4 x 35mm) Incoming	Safe Working Loads (kN)				Characteristic Capacity (kN)			
			Uplift Short Term	Masonry Crushing Strength			Uplift	Masonry Crushing Strength		
				2.8N/mm <sup>2</sup>	3.5N/mm <sup>2</sup>	7.0N/mm <sup>2</sup>		2.8N/mm <sup>2</sup>	3.5N/mm <sup>2</sup>	7.0N/mm <sup>2</sup>
SB-JHIR	No	2	n/a	3.68	4.60	4.60	n/a	6.61	8.27	8.27
SB-JHIR	Yes	2	1.00	6.00	7.54	11.00	2.00	11.17	13.97	23.04

### Enhanced Uplift

- Fixings into the incoming joist/truss are required to resist uplift
- Increased uplift figures can be achieved by nailing the additional triangular nail holes into the incoming member
- Web stiffeners required for I-Joists, 2No end blocks required for Open Web Joists & minimum bottom chord depth/vertical required for trusses

Fixings (3.4 x 35mm) Incoming	Safe Working Loads (kN)			Characteristic Capacity (kN)
	Uplift - Short Term	Uplift - Medium Term	Uplift - Long Term	Uplift
5	2.25	2.14	1.87	4.50

- Requires minimum **3 courses (675mm)** of masonry above to achieve values

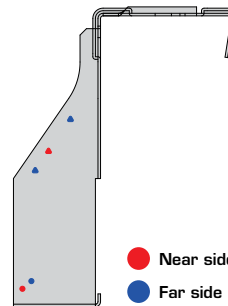

Hanger Depth (mm)	Min Timber Depth (mm)
225	172

### Incorrect Installation

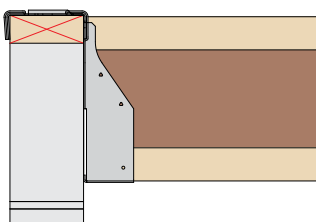

Do not install the hanger onto a timber wall plate.

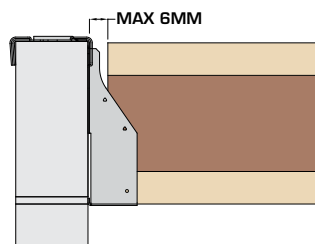

Do not install the hanger with a gap exceeding 6mm between the joist/truss and the hanger.

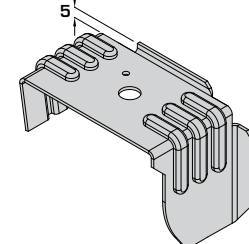

Do not flatten the 5mm upstands on the hanger top flanges. These are critical to the performance.

## Rapid Build Masonry Joist Hanger

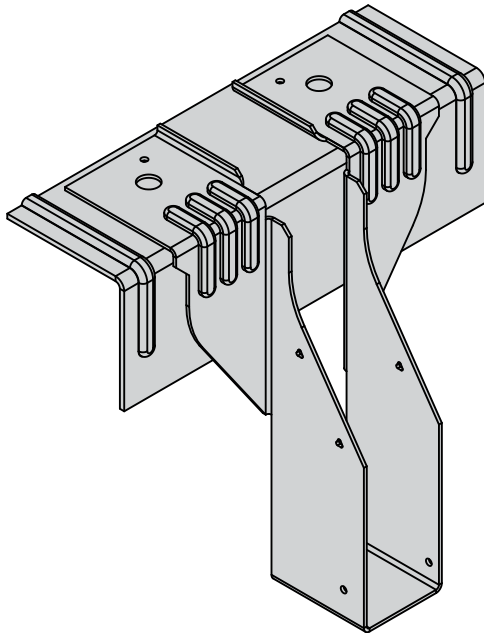

The RB-JHI hanger is a timber to masonry hanger range designed for use with I-Joists, open web & solid timber joists/trusses. The RB-JHI combines the standard JHI hanger with a reinforced top plate to provide a superior level of performance.

### Features & Benefits

- The addition of the reinforced top plate keeps the hanger in position eliminating the need for masonry above (unless required for further additional performance)
- Supporting block work only needs to cure for 3 days instead of the standard 28 days for traditional masonry hangers, speeding up the build process
- A major contribution to compliance with air leakage - Part L1 Building Regulations

### Material Specification

- Galvanised mild steel - Z600

### Fixings

Fixings required into incoming member only. No fixings required into masonry.

Code	Description	Box Qty
547389	3.4 x 35mm Square Twist Nails - LOOSE	500
141185	3.4 x 35mm Square Twist Nails - COLLATED*	2,500

\*For use with Paslode PPN35C

### Available Sizes

Hanger Width (W) (mm)	Hanger Depth (H) (mm)								
	150	175	195	225	240	250	300	350	400
39	RB-JHI-39-150	RB-JHI-39-175	RB-JHI-39-195	RB-JHI-39-225	RB-JHI-39-240	RB-JHI-39-250	RB-JHI-39-300	RB-JHI-39-350	RB-JHI-39-400
46	RB-JHI-46-150	RB-JHI-46-175	RB-JHI-46-195	RB-JHI-46-225	RB-JHI-46-240	RB-JHI-46-250	RB-JHI-46-300	RB-JHI-46-350	RB-JHI-46-400
50	RB-JHI-50-150	RB-JHI-50-175	RB-JHI-50-195	RB-JHI-50-225	RB-JHI-50-240	RB-JHI-50-250	RB-JHI-50-300	RB-JHI-50-350	RB-JHI-50-400
55	-	-	-	RB-JHI-55-225	RB-JHI-55-240	-	RB-JHI-55-300	-	-
61	-	-	RB-JHI-61-195	RB-JHI-61-225	RB-JHI-61-240	-	RB-JHI-61-300	RB-JHI-61-350	RB-JHI-61-400
65	RB-JHI-65-150	RB-JHI-65-175	RB-JHI-65-195	RB-JHI-65-225	RB-JHI-65-240	RB-JHI-65-250	RB-JHI-65-300	RB-JHI-65-350	RB-JHI-65-400
72	-	-	RB-JHI-72-195	RB-JHI-72-225	RB-JHI-72-240	-	RB-JHI-72-300	RB-JHI-72-350	RB-JHI-72-400
75	RB-JHI-75-150	RB-JHI-75-175	RB-JHI-75-195	RB-JHI-75-225	RB-JHI-75-240	RB-JHI-75-250	RB-JHI-75-300	RB-JHI-75-350	RB-JHI-75-400
78	-	-	RB-JHI-78-195	RB-JHI-78-225	RB-JHI-78-240	RB-JHI-78-250	RB-JHI-78-300	RB-JHI-78-350	RB-JHI-78-400
92	RB-JHI-92-150	RB-JHI-92-175	RB-JHI-92-195	RB-JHI-92-225	RB-JHI-92-240	RB-JHI-92-250	RB-JHI-92-300	RB-JHI-92-350	RB-JHI-92-400
100	RB-JHI-100-150	RB-JHI-100-175	RB-JHI-100-195	RB-JHI-100-225	RB-JHI-100-240	RB-JHI-100-250	RB-JHI-100-300	RB-JHI-100-350	RB-JHI-100-400
110	-	-	-	RB-JHI-110-225	RB-JHI-110-240	-	RB-JHI-110-300	-	-
122	-	-	RB-JHI-122-195	RB-JHI-122-225	RB-JHI-122-240	-	RB-JHI-122-300	RB-JHI-122-350	RB-JHI-122-400
125	-	-	RB-JHI-125-195	RB-JHI-125-225	RB-JHI-125-240	RB-JHI-125-250	RB-JHI-125-300	RB-JHI-125-350	RB-JHI-125-400
130	-	-	RB-JHI-130-195	RB-JHI-130-225	RB-JHI-130-240	-	RB-JHI-130-300	RB-JHI-130-350	-
138	-	-	RB-JHI-138-195	RB-JHI-138-225	RB-JHI-138-240	RB-JHI-138-250	RB-JHI-138-300	RB-JHI-138-350	RB-JHI-138-400
144	-	-	RB-JHI-144-195	RB-JHI-144-225	RB-JHI-144-240	-	RB-JHI-144-300	RB-JHI-144-350	RB-JHI-144-400
150	-	-	RB-JHI-150-195	RB-JHI-150-225	RB-JHI-150-240	RB-JHI-150-250	RB-JHI-150-300	RB-JHI-150-350	RB-JHI-150-400
156	-	-	-	RB-JHI-156-225	RB-JHI-156-240	-	-	-	-
183	-	-	RB-JHI-183-195	RB-JHI-183-225	RB-JHI-183-240	-	RB-JHI-183-300	RB-JHI-183-350	RB-JHI-183-400
198	-	-	RB-JHI-198-195	RB-JHI-198-225	RB-JHI-198-240	RB-JHI-198-250	RB-JHI-198-300	RB-JHI-198-350	RB-JHI-198-400
225	-	-	-	RB-JHI-225-225	RB-JHI-225-240	RB-JHI-225-250	RB-JHI-225-300	-	-
250	-	-	-	RB-JHI-250-225	RB-JHI-250-240	RB-JHI-250-250	RB-JHI-250-300	-	-

### Dimensions (mm)

#### RB-JHI - 39-138MM WIDE

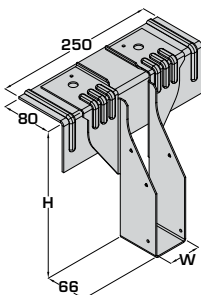

RB-JHI-W-H  
Example: RB-JHI-50-225

#### RB-JHI - 144-198MM WIDE

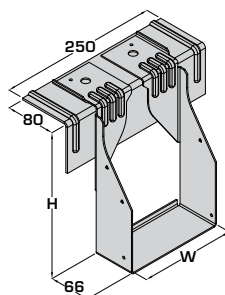

RB-JHI-W-H  
Example: RB-JHI-150-225

#### RB-JHIR - RETURN

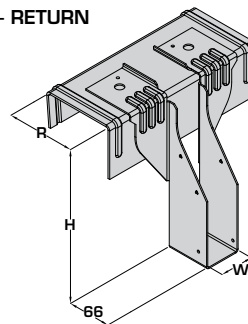

RB-JHIR-W-H-R  
Example: RB-JHIR-50-225-100  
(Returns available to suit 100 & 140mm wide block work)

## Rapid Build Masonry Joist Hanger

### In Situ

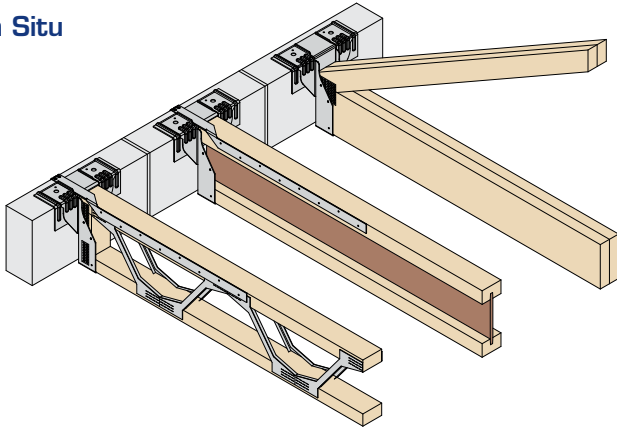

- Suitable for use with Open Web Joists, I-Joists and trusses
- Non return hangers are suitable with no masonry above. Return only required for increased load capacity



- **No masonry** is required above the hanger (unless stated for increased load capacity).
- The masonry supporting the hanger must be cured for **3 days** prior to loading the floor.
- The RB-JHI/RB-JHIR does not provide restraint, therefore restraint straps may be required (see pages 132 - 133)

### Load Data

Hanger Type	Masonry Above (Min 675mm)	Fixings (3.4 x 35mm)	Safe Working Loads (kN)				Characteristic Capacity (kN)			
			Uplift Short Term	Masonry Crushing Strength			Uplift	Masonry Crushing Strength		
				Incoming	2.8N/mm <sup>2</sup>	3.5N/mm <sup>2</sup>		7.0N/mm <sup>2</sup>	2.8N/mm <sup>2</sup>	3.5N/mm <sup>2</sup>
RB-JHI	No	2	n/a	6.98	8.73	11.66	n/a	12.56	15.71	21.26
RB-JHIR	No	2	n/a	8.82	11.03	15.73	n/a	16.00	20.01	28.31
RB-JHI	Yes	2	1.00	10.51	13.14	22.00	2.00	19.83	24.79	39.60
RB-JHIR	Yes	2	1.00	10.51	13.14	22.00	2.00	19.83	24.79	39.60

### Enhanced Uplift

- Fixings into the incoming joist/truss are required to resist uplift
- Increased uplift figures can be achieved by nailing the additional triangular nail holes into the incoming member
- Web stiffeners required for I-Joists, 2No end blocks required for Open Web Joists & minimum bottom chord depth/vertical required for trusses

Fixings (3.4 x 35mm)	Safe Working Loads (kN)			Characteristic Capacity (kN)
	Incoming	Uplift - Short Term	Uplift - Medium Term	Uplift
5	2.25	2.14	1.87	4.50

- Requires minimum **3 courses (675mm)** of masonry above to achieve values

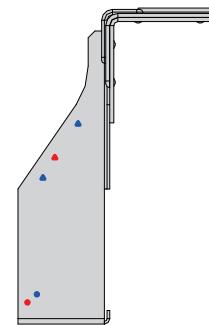

Hanger Depth (mm)	Min Timber Depth (mm)
150	84
175 - 195	122
225 - 240	172
250	195
300	235
350	300
400	350

### Incorrect Installation

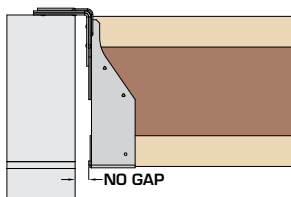

Do not install the hanger with a gap between the hanger and the face of the block work.

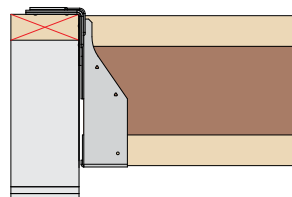

Do not install the hanger onto a timber wall plate.

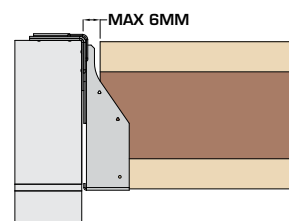

Do not install the hanger with a gap exceeding 6mm between the joist/truss and the hanger.

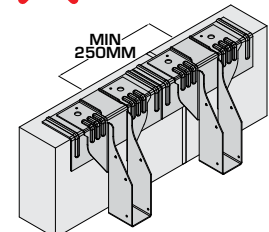

Do not cut/modify the top flanges. These are critical to the performance.

## Flexible Masonry Hanger



The FMHI hanger is used to support joists and trusses from masonry walls in high load situations with 675mm masonry above.

### Features & Benefits

- Increased top flange to allow for greater load distribution
- Options available for skewed, offset, dropped and straddle connections

### Material Specification

- 4mm top plate & 3mm stirrup - mild steel with zinc phosphate undercoat and an organic bituminous top coat to BS EN845-1:2013+A1:2016

### Fixings

Fixings required into incoming member only.

Code	Description	Box Qty
547389	3.4 x 35mm Square Twist Nails - LOOSE	500
141185	3.4 x 35mm Square Twist Nails - COLLATED*	2,500

\*For use with Paslode PPN35Ci

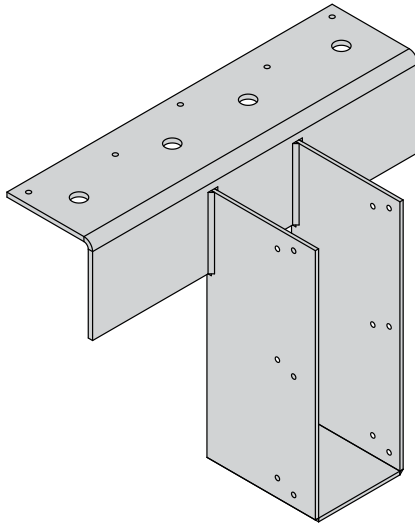

FMHI - 4mm top plate, 3mm stirrup, 100mm bearing  
 FTHI - 4mm top plate, 4mm stirrup, 150mm bearing

### Available Sizes

Hanger Width (W) (mm)	Hanger Depth (H) (mm)								
	150	175	195	225	240	250	300	350	400
39	-	-	FMHI-39-195	FMHI-39-225	FMHI-39-240	FMHI-39-250	FMHI-39-300	FMHI-39-350	FMHI-39-400
46	-	-	FMHI-46-195	FMHI-46-225	FMHI-46-240	FMHI-46-250	FMHI-46-300	FMHI-46-350	FMHI-46-400
50	-	-	FMHI-50-195	FMHI-50-225	FMHI-50-240	FMHI-50-250	FMHI-50-300	FMHI-50-350	-
55	-	-	-	RB-JHI-55-225**	RB-JHI-55-240**	-	RB-JHI-55-300**	-	-
61	-	-	FMHI-61-195	RB-JHI-61-225**	RB-JHI-61-240**	-	RB-JHI-61-300**	FMHI-61-350	FMHI-61-400
65	FMHI-65-150	-	FMHI-65-195	RB-JHI-65-225**	RB-JHI-65-240**	RB-JHI-65-250**	RB-JHI-65-300**	RB-JHI-65-350**	-
72	-	-	RB-JHI-72-195**	RB-JHI-72-225**	RB-JHI-72-240**	-	RB-JHI-72-300**	RB-JHI-72-350**	RB-JHI-72-400**
75	-	-	FMHI-75-195	FMHI-75-225	FMHI-75-240	FMHI-75-250	FMHI-75-300	FMHI-75-350	FMHI-75-400
78	-	-	FMHI-78-195	FMHI-78-225	FMHI-78-240	FMHI-78-250	FMHI-78-300	FMHI-78-350	FMHI-78-400
92	FMHI-92-150	FMHI-92-175	FMHI-92-195	FMHI-92-225	FMHI-92-240	FMHI-92-250	FMHI-92-300	FMHI-92-350	FMHI-92-400
100	-	-	FMHI-100-195	FMHI-100-225	FMHI-100-240	FMHI-100-250	FMHI-100-300	FMHI-100-350	FMHI-100-400
110	-	-	-	RB-JHI-110-225**	RB-JHI-110-240**	-	RB-JHI-110-300**	-	-
122	-	-	FMHI-122-195	RB-JHI-122-225**	RB-JHI-122-240**	-	RB-JHI-122-300**	RB-JHI-122-350**	RB-JHI-122-400**
125	-	-	FMHI-125-195	FMHI-125-225	FMHI-125-240	RB-JHI-125-250**	FMHI-125-300	FMHI-125-350	FMHI-125-400
130	-	-	FMHI-130-195	RB-JHI-130-225**	RB-JHI-130-240**	-	RB-JHI-130-300**	RB-JHI-130-350**	-
138	-	-	FMHI-138-195	RB-JHI-138-225**	RB-JHI-138-240**	RB-JHI-138-250**	RB-JHI-138-300**	RB-JHI-138-350**	RB-JHI-138-400**
144	-	-	FMHI-144-195	RB-JHI-144-225**	RB-JHI-144-240**	-	RB-JHI-144-300**	RB-JHI-144-350**	RB-JHI-144-400**
150	-	-	RB-JHI-150-195**	RB-JHI-150-225**	RB-JHI-150-240**	RB-JHI-150-250**	RB-JHI-150-300**	RB-JHI-150-350**	RB-JHI-150-400**
183	-	-	FMHI-183-195	RB-JHI-183-225**	RB-JHI-183-240**	-	RB-JHI-183-300**	RB-JHI-183-350**	RB-JHI-183-400**
198	-	-	FMHI-198-195	RB-JHI-198-225**	RB-JHI-198-240**	RB-JHI-198-250**	RB-JHI-198-300**	FMHI-198-350	FMHI-198-400
225	-	-	-	RB-JHI-225-225**	RB-JHI-225-240**	RB-JHI-225-250**	RB-JHI-225-300**	FMHI-225-350	FMHI-225-400
250	-	-	-	RB-JHI-250-225**	RB-JHI-250-240**	RB-JHI-250-250**	RB-JHI-250-300**	FMHI-250-350	FMHI-250-400
300	-	-	-	FMHI-300-225	-	FMHI-300-250	FMHI-300-300	FMHI-300-350	FMHI-300-400

\*\*FMHI hanger can be swapped directly with RB-JHI

### Dimensions (mm)

FMHI 39 - 144MM WIDE

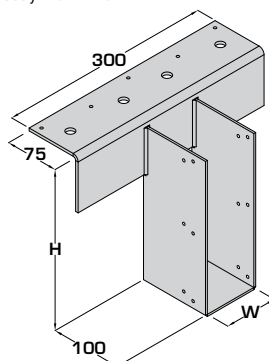

FMHI-W-H  
 Example: FMHI-100-225

FMHI 150 - 300MM WIDE

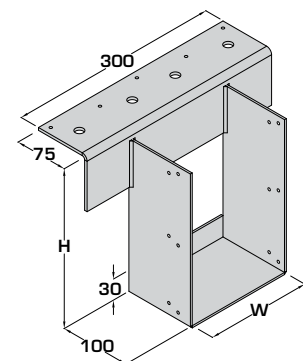

FMHI-W-H  
 Example: FMHI-225-350

## Flexible Masonry Hanger

### Dimensions (mm) - Continued

FMHI

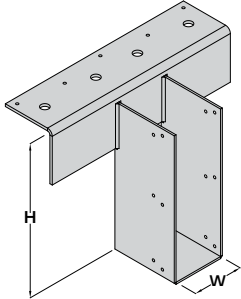

FMHI-W-H

Example:  
FMHI-75-225

FMHIR - RETURN

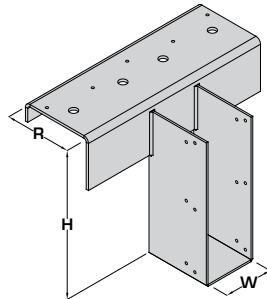

FMHIR-W-H-R

Example:  
FMHIR-100-225-100  
(2mm added to return for tolerance)

FMHIO - OFFSET

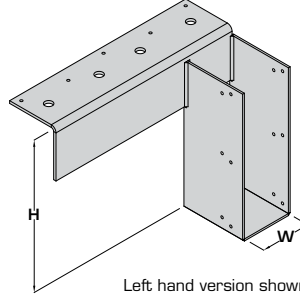

FMHIO-W-H-OFFSET DIRECTION

Example:  
FMHIO-75-225-R  
FMHIO-75-255-L

FMHIS - SKEW

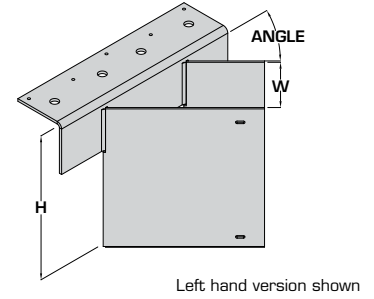

FMHIS-W-H-DIRECTION-ANGLE

Example:  
FMHIS-75-225-L-45  
FMHIS-100-250-R-67.5  
(skews from 30-87.5° in 2.5° increments)

FMHID - DROPPED

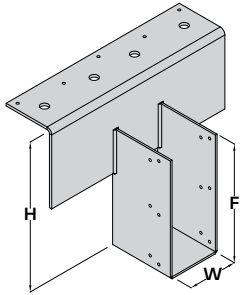

FMHID-W-H-F

Example:  
FMHID-75-260-240

FMHIST - STRADDLE

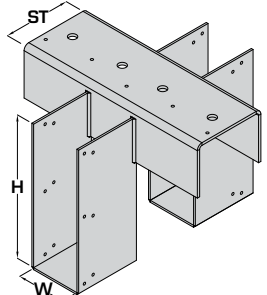

FMHIST-W-H-ST

Example:  
FMHIST-75-225-100  
(2mm added to straddle for tolerance)

FMHIOR - OFFSET & RETURN

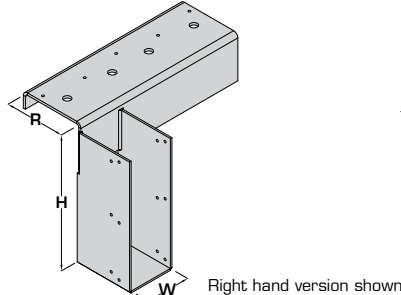

FMHIOR-W-H-OFFSET DIRECTION-R

Example:  
FMHIOR-75-225-R-100  
(2mm added to return for tolerance)

FMHIRS - SKEW & RETURN

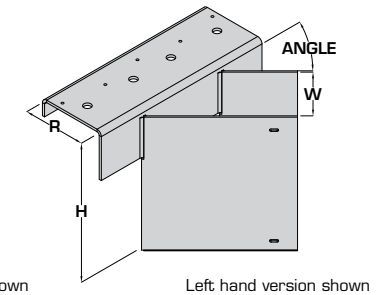

FMHIRS-W-H-DIRECTION-ANGLE-R

Example:  
FMHIRS-75-225-R-45-100  
FMHIRS-75-225-L-45-100

### In Situ

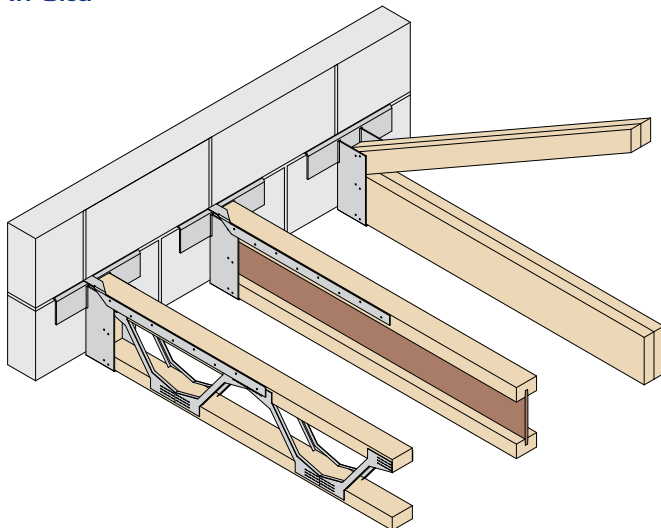

- Suitable for use with Open Web Joists, I-Joists and trusses
- Floor can be propped with acroprops and fully decked but must not be fully loaded until the masonry above has fully cured



- A minimum of **3 courses (675mm)** of masonry above is required for hanger to achieve loads stated
- The masonry above must be fully cured for **28 days** prior to loading the floor
- All hangers in this range do not provide restraint, therefore restraint straps may be required for joist applications (see pages 132 - 133)

## Flexible Masonry Hanger

### Load Data

Hanger Type	Fixings (3.4 x 35mm) Incoming	Angle	Safe Working Loads (kN)					Characteristic Capacity (kN)				
			Uplift Short Term	Masonry Crushing Strength				Uplift	Masonry Crushing Strength			
				2.8N/mm <sup>2</sup>	3.5N/mm <sup>2</sup>	7.0N/mm <sup>2</sup>	Padstone		2.8N/mm <sup>2</sup>	3.5N/mm <sup>2</sup>	7.0N/mm <sup>2</sup>	Padstone
FMHIS FMHIRS	4	30 - 42.5°	1.00	4.99	6.24	9.20	10.00	2.00	9.98	12.48	18.30	20.00
		45 - 57.5°	1.00	6.24	7.80	11.00	11.90	2.00	12.48	15.60	22.90	25.00
		60 - 72.5°	1.00	7.48	9.36	12.90	13.80	2.00	14.97	18.72	27.50	30.00
		75 - 87.5°	1.00	8.72	10.90	14.80	15.60	2.00	17.44	21.80	32.00	35.00
FMHI FMHIR FMHID FMHIO FMHIOR FMHIST	4	90°	1.00	10.51	13.14	21.60	21.60	2.00	19.83	24.79	43.00	43.00

### Enhanced Uplift

- Fixings into the incoming joist/truss are required to resist uplift
- Increased uplift figures can be achieved by nailing the additional triangular nail holes into the incoming member

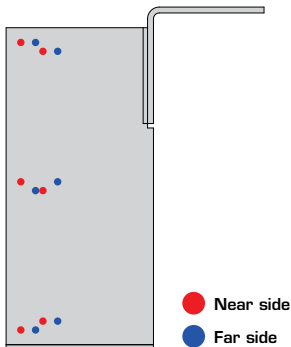

Hanger Depth (H) (mm)	Min Timber Depth (mm)	Fixings (3.4 x 35mm)	Safe Working Loads (kN)			Characteristic Capacity (kN)
		Incoming	Uplift - Short Term	Uplift - Medium Term	Uplift - Long Term	Uplift
150	97	8	2.54	2.41	2.11	4.67
175 - 195	122					
225 - 240	147					
250	147					
300	172					
350	197					
400	222	12	7.70	7.33	6.41	14.72
150 - 400	FULL DEPTH					

- Enhanced uplift only applicable for 90° hangers over 72mm wide

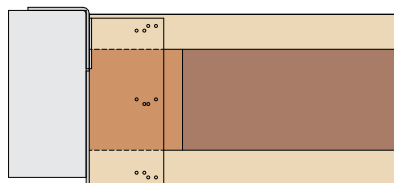

Web stiffeners required for I-Joists

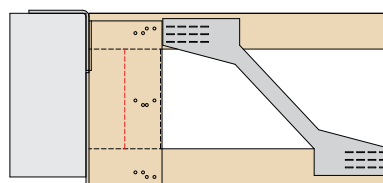

2No end blocks required for Open Web Joists  
Block must be the full width of the joist

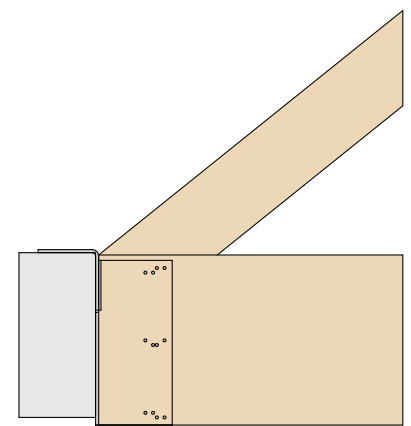

Minimum bottom chord depth or vertical required for trusses

Plates omitted for clarity

# M-STD/M-RTN



## Very High Load Masonry Hanger

The Masonry Standard and Masonry Return hangers are used to support joists and trusses from masonry walls in very high load situations.

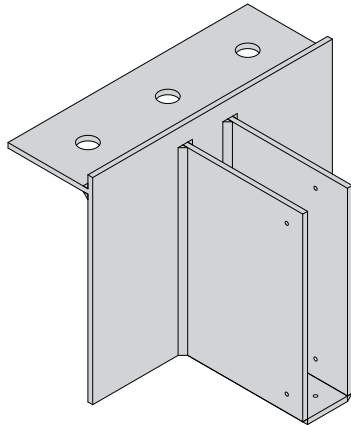

MASONRY-STD

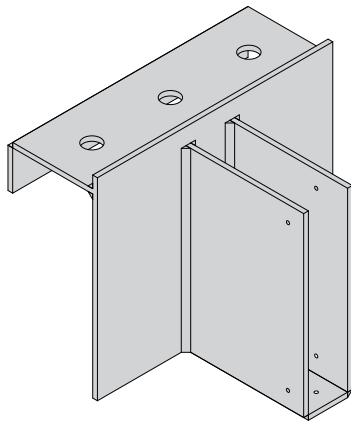

MASONRY-RTN

### Features & Benefits

- Partial penetration butt welds allow for greater performance over FMHI hanger
- Available in 2 thickness options to accommodate higher loads
- Return option available to keep hanger tight to masonry wall

### Material Specification

- 6mm & 8mm mild steel with zinc phosphate undercoat and an organic bituminous top coat to BS EN845-1:2013+A1:2016

### Fixings

Fixings required into incoming member only. No fixings required into masonry.

Code	Description	Box Qty
547389	3.4 x 35mm Square Twist Nails - LOOSE	500
141185	3.4 x 35mm Square Twist Nails - COLLATED*	2,500

\*For use with Paslode PPN35Ci

### Dimensions (mm)

#### MASONRY-STD

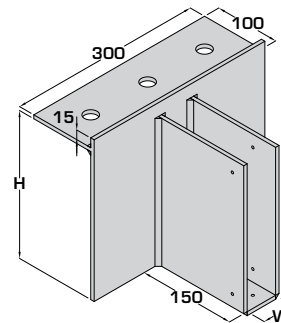

MASONRY-STD-THICKNESS-W-H

Example:  
MASONRY-STD-6MM-100-225

#### MASONRY-RTN

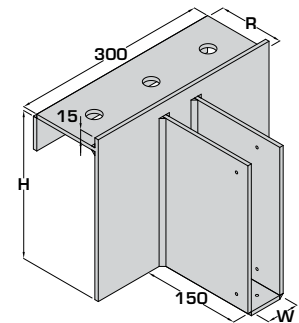

MASONRY-RTN-THICKNESS-W-H-R

Example:  
MASONRY-RTN-8MM-100-225-100

### Available Sizes

#### Hanger Widths (mm):

39, 46, 50, 55, 61, 65, 72, 75, 78, 92, 100, 110, 122, 125, 130, 138, 144, 150, 183, 198, 225, 250, 300

#### Hanger Depths (mm):

150, 175, 195, 225, 240, 250, 300, 350, 400

Contact Technical Support for skewed and straddle options

### Load Data (values based on no masonry above)

Hanger Thickness	Fixings (3.4 x 35mm) Incoming	Uplift Short Term***	Safe Working Loads (kN)				Characteristic Capacity (kN)				
			Masonry Crushing Strength				Uplift***	Masonry Crushing Strength			
			2.8N/mm <sup>2</sup>	3.5N/mm <sup>2</sup>	7.0N/mm <sup>2</sup>	Padstone (Min C30)		2.8N/mm <sup>2</sup>	3.5N/mm <sup>2</sup>	7.0N/mm <sup>2</sup>	Padstone (Min C30)
6mm	6	1.00	15.00	19.00	25.00**	35.00**	2.00	30.00	38.00	50.00**	70.00**
8mm	6	1.00	20.00	21.00	30.00**	45.00**	2.00	40.00	42.00	60.00**	90.00**

\*\*SPECIFY A RETURN TO KEEP HANGER TIGHT TO BLOCK

\*\*\*Minimum 675mm masonry required above to achieve uplift capacity.

## Variable Skew Masonry Hanger

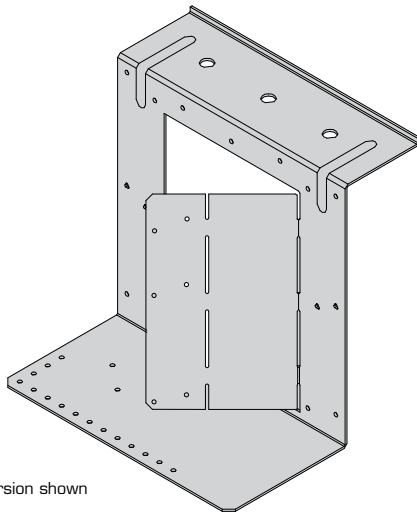

Right Hand version shown

The **VSM hanger** is used to support joists and trusses up to **97mm** wide from masonry walls in skewed applications between **30 - 90°**.

### Features & Benefits

- Unique hanger design provides a variable skew angle between 30° - 90°
- No need to mitre cut joists
- Angle scale on base to ease adjustment

### Material Specification

- Galvanised mild steel - Z600

### Fixings

Fixings required into incoming member only. No fixings required into masonry.

Code	Description	Box Qty
547389	3.4 x 35mm Square Twist Nails - LOOSE	500
141185	3.4 x 35mm Square Twist Nails - COLLATED*	2,500

\*For use with Paslode PPN35Ci

### Available Sizes

Min Joist Width (mm)	Max Joist Width (mm)	Handing	Hanger Depth (H) (mm)			
			225	240	300	>300
38	97	Right	VSM-225-R	VSM-240-R	VSM-300-R	See FMHIS on pages 18 - 20
38	97	Left	VSM-225-L	VSM-240-L	VSM-300-L	
>97			See FMHIS on pages 20 - 22			

### Dimensions (mm)

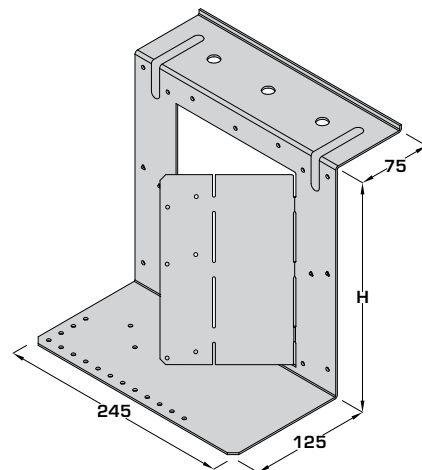

#### Left Hand

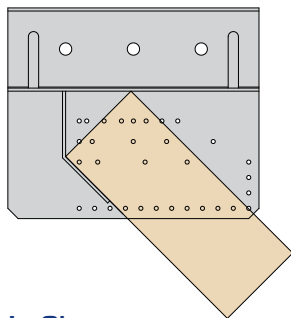

#### Right Hand

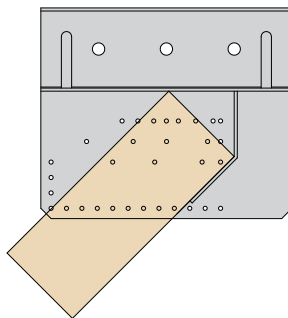

### In Situ

- Suitable for use with Open Web Joists, I-Joists and trusses.
- Floor can be propped with acroprops and fully decked but must not be fully loaded until the masonry above has fully cured.



- A minimum of **3 courses (675mm)** of masonry above is required for hanger to achieve loads stated.
- The masonry above must be fully cured for **28 days** prior to loading the floor.

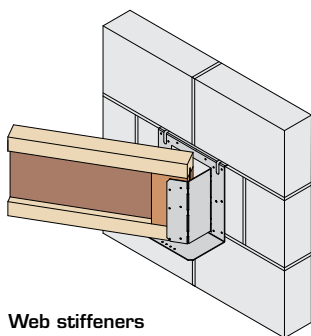

Web stiffeners required for I-Joists

Plates and additional block work have been omitted for clarity

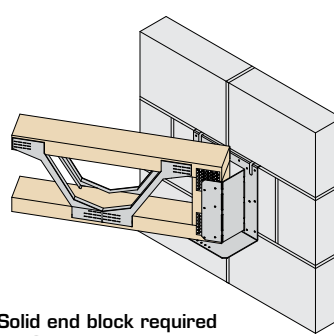

Solid end block required for Open Web Joists

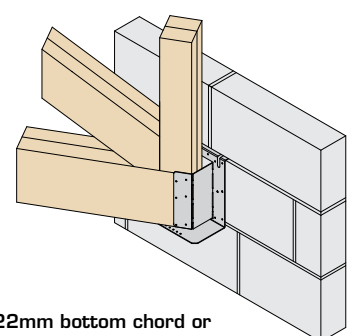

222mm bottom chord or vertical required for trusses



## Variable Skew Masonry Hanger

### Load Data

Hanger Depth (mm)	Fixings (3.4 x 35mm)	Safe Working Loads (kN)				Characteristic Capacity (kN)			
		Uplift - Short Term	Masonry Crushing Strength			Uplift	Masonry Crushing Strength		
			2.8N/mm <sup>2</sup>	3.5N/mm <sup>2</sup>	7.0N/mm <sup>2</sup>		2.8N/mm <sup>2</sup>	3.5N/mm <sup>2</sup>	7.0N/mm <sup>2</sup>
225/240/300	6	1.60	4.39	5.49	5.49	2.40	8.32	10.40	10.40

### Installation Instructions

#### STAGE 1

Adjust side plate to approximate angle between 30° and 90° using scale on base of hanger, bending only once. Refer to the angle table below to determine if one or two bends are required.

Single Bend	Joist Width (mm)	Single bend	Double Bend
		35	n/a
38	n/a	n/a	30-90°
44	n/a	n/a	30-90°
45	n/a	n/a	30-90°
47	n/a	n/a	30-90°
51	30-32°	>32-90°	>32-90°
53	30-32°	>32-90°	>32-90°
58	30-34°	>34-90°	>34-90°
59	30-34°	>34-90°	>34-90°
60	30-34°	>35-90°	>35-90°
63	30-37°	>37-90°	>37-90°
70	30-39°	>39-90°	>39-90°
72	30-40°	>40-90°	>40-90°
76	30-42°	>42-90°	>42-90°
88	30-46°	>46-90°	>46-90°
89	30-46°	>46-90°	>46-90°
90	30-46°	>46-90°	>46-90°
94	30-48°	>48-90°	>48-90°
97	30-49°	>49-90°	>49-90°

#### STAGE 2

Position VSM flush against masonry.

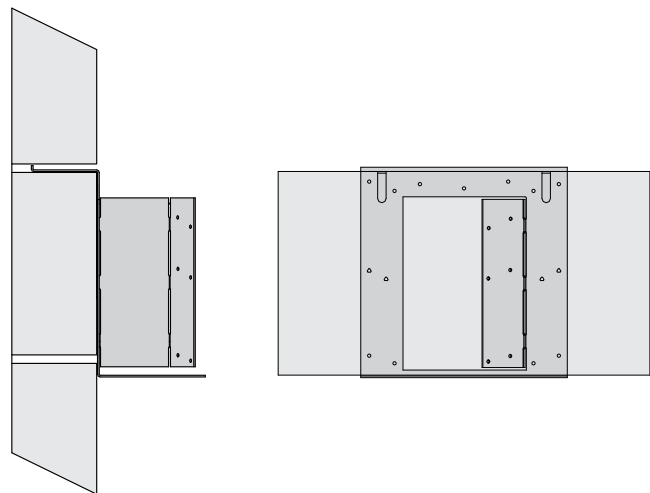

#### STAGE 3

Locate incoming member and adjust side plate to correct angle, ensuring maximum gap between incoming joist and back plate is no greater than 3mm.

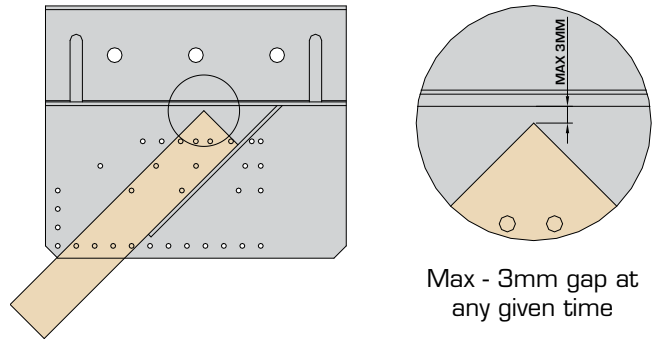

#### STAGE 4

Fix to incoming member using 6No 3.4 x 35mm square twist nails. Where incoming member is an I-joist, web stiffeners must be fixed as per I-joist manufacturer's guidelines.

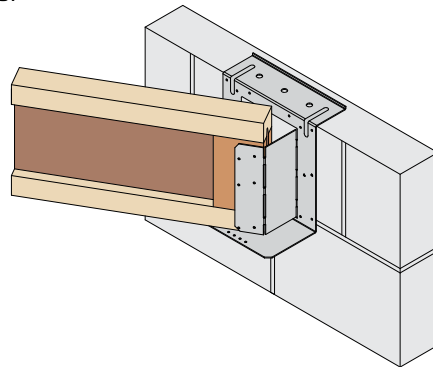

Ensure that 1No inner nail hole (indicated in red) and 1No outer nail hole (indicated in red) are filled on the underside with a 3.4 x 35mm square twist nail.

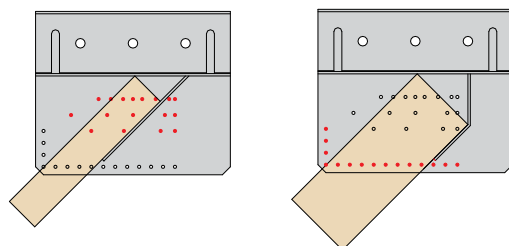

# RA RANGE



## Restraint Angle Range



The RA hanger range comprises of 3 hangers to suit all applications: the RA, HRAD and RADS. This is a timber to masonry hanger range designed for use with I-Joists, Open Web Joists, LVL & Glulam. The hangers provide lateral restraint<sup>(1)</sup> and require no masonry above to perform to their full capacity.

### Features & Benefits

- Provides lateral restraint (<sup>(1)</sup>equivalent to restraint straps at 2m centres. Additional straps required for buildings over 2 storeys or openings greater than 600mm)
- No coursing option required as RA range supports joists on top of previous block course, allowing joist to be built in at one end without adjustment
- Supporting block work only needs to cure for 3 days instead of the standard 28 days for traditional masonry hangers, speeding up the build process

### Material Specification

- Galvanised mild steel - Z600

### Fixings

Fixings required into incoming member only. No fixings required into masonry.

Code	Description	Box Qty
547389	3.4 x 35mm Square Twist Nails - LOOSE	500
141185	3.4 x 35mm Square Twist Nails - COLLATED*	2,500

\*For use with Paslode PPN35Ci

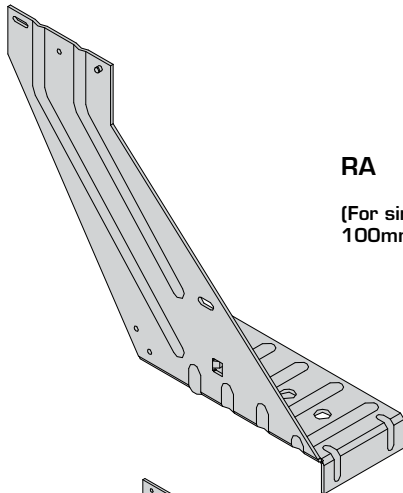

**RA**

(For single joists up to 100mm wide)

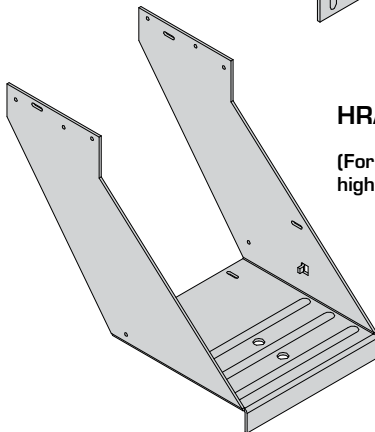

**HRAD**

(For double joists & high loads)

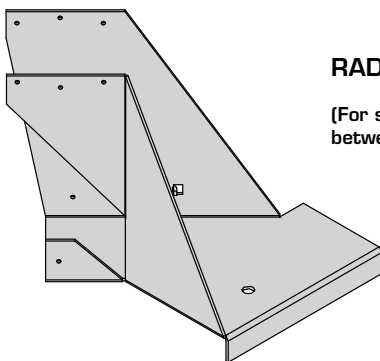

**RADS**

(For skewed applications between 30 - 87.5°)

### Height Suitability\*\*

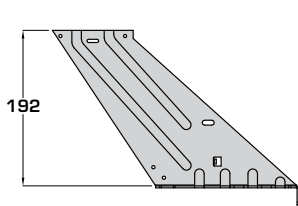

**RA-195**

(To suit 195 - 200 deep I-Joists)  
(To suit 195 - 200 deep Open Web Joists)

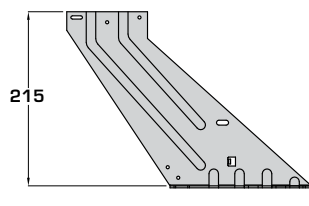

**RA-220**

(To suit 220 deep I-Joists)  
(To suit 219 - 225 deep Open Web Joists)

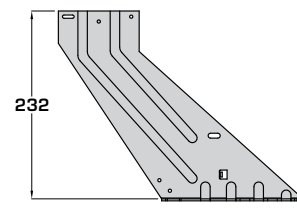

**RA-240**

(To suit 235 - 245 deep I-Joists)  
(To suit 253 - 254 deep Open Web Joists)

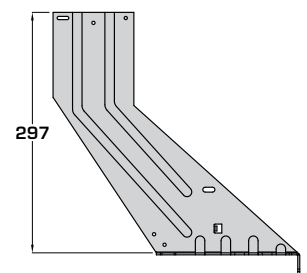

**RA-300**

(To suit 300 - 302 deep I-Joists)  
(To suit 304 deep Open Web Joists)

\*\*Also applies to HRAD and RADS hangers

# RA RANGE



## Restraint Angle Range

### Available Sizes

Hanger Width (mm)	Hanger Depth (mm)			
	195	220	240	300
One size (to suit joist widths 38 - 97mm wide)	RA-195	RA-220	RA-240	RA-300
39	HRAD-195-39	HRAD-220-39	HRAD-240-39	HRAD-300-39
46	HRAD-195-46	HRAD-220-46	HRAD-240-46	HRAD-300-46
50	HRAD-195-50	HRAD-220-50	HRAD-240-50	HRAD-300-50
55	-	-	HRAD-240-55	HRAD-300-55
61	HRAD-195-61	HRAD-220-61	HRAD-240-61	HRAD-300-61
65	HRAD-195-65	HRAD-220-65	HRAD-240-65	HRAD-300-65
72	HRAD-195-72	HRAD-220-72	HRAD-240-72	HRAD-300-72
75	HRAD-195-75	HRAD-220-75	HRAD-240-75	HRAD-300-75
78	HRAD-195-78	HRAD-220-78	HRAD-240-78	HRAD-300-78
92	HRAD-195-92	HRAD-220-92	HRAD-240-92	HRAD-300-92
100	HRAD-195-100	HRAD-220-100	HRAD-240-100	HRAD-300-100
110	-	-	HRAD-240-110	HRAD-300-110
122	HRAD-195-122	HRAD-220-122	HRAD-240-122	HRAD-300-122
125	HRAD-195-125	HRAD-220-125	HRAD-240-125	HRAD-300-125
130	HRAD-195-130	HRAD-220-130	HRAD-240-130	HRAD-300-130
138	HRAD-195-138	HRAD-220-138	HRAD-240-138	HRAD-300-138
144	HRAD-195-144	HRAD-220-144	HRAD-240-144	HRAD-300-144
150	HRAD-195-150	HRAD-220-150	HRAD-240-150	HRAD-300-150
183	HRAD-195-183	HRAD-220-183	HRAD-240-183	HRAD-300-183
198	HRAD-195-198	HRAD-220-198	HRAD-240-198	HRAD-300-198
225	HRAD-195-225	HRAD-220-225	HRAD-240-225	HRAD-300-225
250	HRAD-195-250	HRAD-220-250	HRAD-240-250	HRAD-300-250
300	HRAD-195-300	HRAD-220-300	HRAD-240-300	HRAD-300-300

All hangers are suitable for 100mm wide block work as standard.

We also offer this hanger range to suit 140mm wide block work.

### TO ORDER:

RA-195-140

HRAD-220-198-140

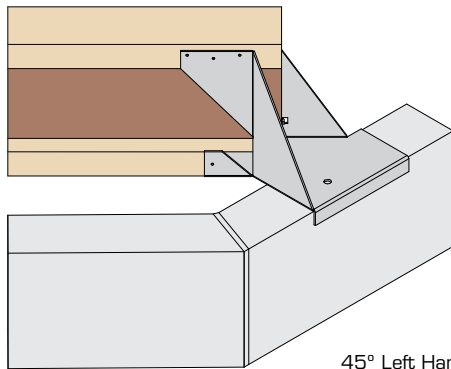

45° Left Hand Shown

For skewed connections the RADS is made to order upon request

### TO ORDER:

RAD-S-ANGLE-ORIENTATION-DEPTH-WIDTH

Example: RAD-S-45-L-240-46 (to suit 100mm block work)

Available in angles between 30 - 87.5°. Increments of 2.5° (30, 32.5, 35, 37.5...)

Also available with 140mm return if required

Example: RAD-S-45-L-240-46-140

### Dimensions (mm)

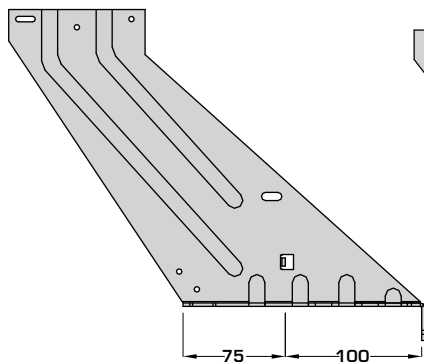

RA

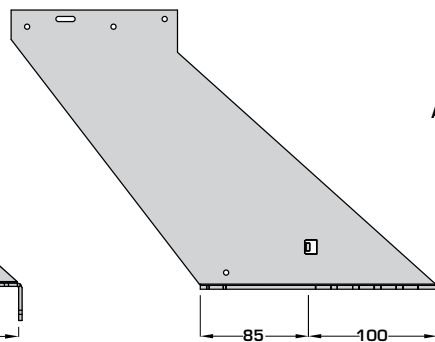

HRAD

(locating tab on opposite side)

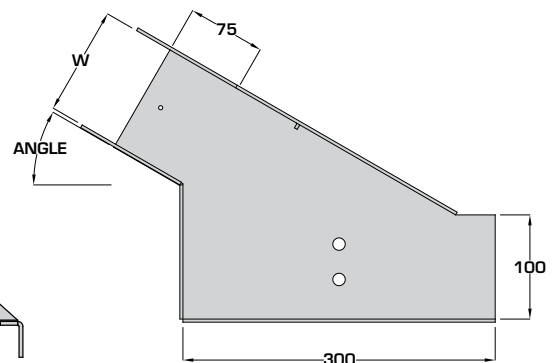

RADS

# RA RANGE



## Restraint Angle Range

### Load Data

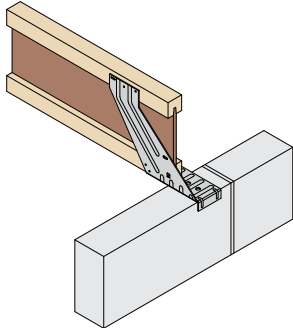

Hanger Type	Fixings (3.4 x 35mm)	Safe Working Loads (kN)				Characteristic Capacity (kN)			
		Uplift Short Term*	Masonry Crushing Strength			Uplift*	Masonry Crushing Strength		
			2.8N/mm <sup>2</sup>	3.5N/mm <sup>2</sup>	7.0N/mm <sup>2</sup>		2.8N/mm <sup>2</sup>	3.5N/mm <sup>2</sup>	7.0N/mm <sup>2</sup>
RA	6	4.00	5.00	6.32	6.32	7.11	9.10	11.38	11.38
HRAD	12	4.00	12.50	15.64	15.64	7.11	22.51	28.14	28.14
RADS	9	4.00	6.20	7.80	7.80	7.11	11.48	14.35	14.35

\*Uplift only applicable when hangers are fully built in with a minimum of 675mm of fully cured masonry above the base plate.

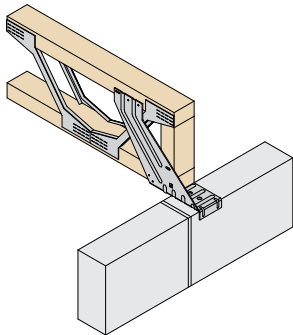

Hanger Type	Fixings (3.4 x 35mm)	Safe Working Loads (kN)				Characteristic Capacity (kN)			
		Uplift Short Term*	Masonry Crushing Strength			Uplift*	Masonry Crushing Strength		
			2.8N/mm <sup>2</sup>	3.5N/mm <sup>2</sup>	7.0N/mm <sup>2</sup>		2.8N/mm <sup>2</sup>	3.5N/mm <sup>2</sup>	7.0N/mm <sup>2</sup>
RA	6	4.00	5.00	6.32	6.32	7.11	9.10	11.38	11.38
HRAD	12	4.00	12.50	15.64	15.64	7.11	22.51	28.14	28.14
RADS	9	4.00	6.20	7.80	7.80	7.11	11.48	14.35	14.35

\*Uplift only applicable when hangers are fully built in with a minimum of 675mm of fully cured masonry above the base plate.

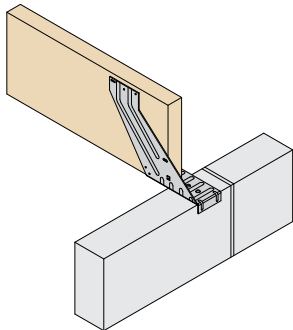

Hanger Type	Fixings (3.4 x 35mm)	Safe Working Loads (kN)				Characteristic Capacity (kN)			
		Uplift Short Term*	Masonry Crushing Strength			Uplift*	Masonry Crushing Strength		
			2.8N/mm <sup>2</sup>	3.5N/mm <sup>2</sup>	7.0N/mm <sup>2</sup>		2.8N/mm <sup>2</sup>	3.5N/mm <sup>2</sup>	7.0N/mm <sup>2</sup>
RA	6	4.00	6.38	7.98	7.98	7.11	11.49	14.37	14.37
HRAD	12	4.00	15.10	18.99	18.99	7.11	27.34	34.18	34.18
RADS	9	4.00	6.20	7.80	7.80	7.11	11.48	14.35	14.35

\*Uplift only applicable when hangers are fully built in with a minimum of 675mm of fully cured masonry above the base plate.

### Incorrect Installation

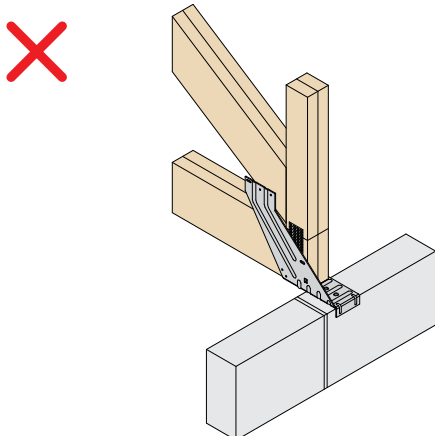

Do not use the RA range with trussed rafters.

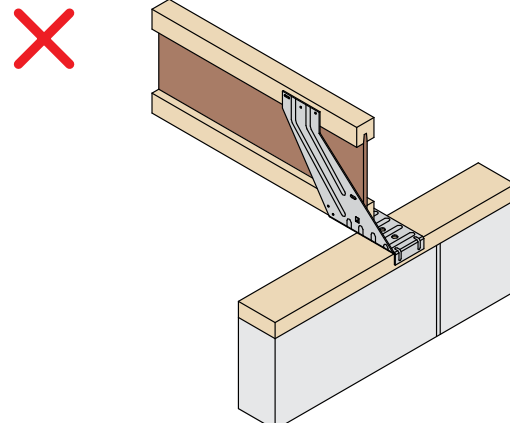

Do not install the RA range onto a timber wall plate.

## Restraint Angle Range

### Installation Instructions

#### STAGE 1 - INSTALLATION

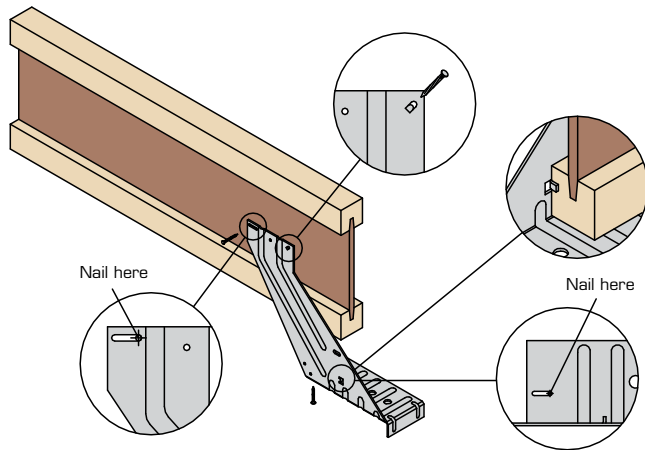

- Ensure joists just fit between the walls
- If using I-joists and they are too long, trim to fit
- Position joist against location tab
- Pre-fix RA to each end of pre-cut joist, nailing through slotted holes in base plate and side flange only, as shown
- Slide to opposite side of slots to provide full 6mm adjustment on wall head
- Always pre-fix hangers at ground level or on scaffolding

#### STAGE 2 - ADJUSTMENT

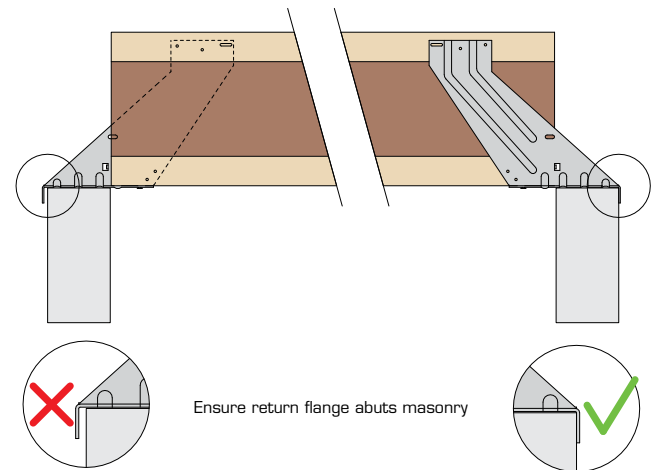

- Locate assembled joist on wall head allowing equal adjustment at both ends
- Adjust each end by tapping with a hammer until return flange is correctly positioned tight against blockwork
- This stage provides a maximum horizontal adjustment of 12mm and suits blockwork built to BS5606:1990 Accuracy in Building

**!** Ensure return flange abuts masonry

#### STAGE 3 - FINAL ADJUSTMENT

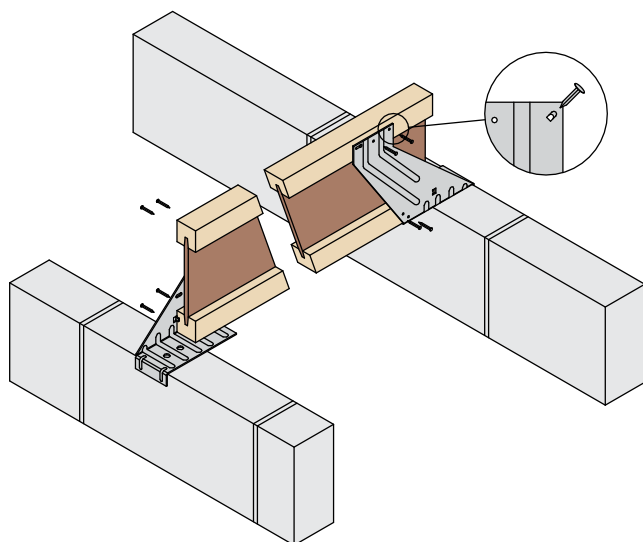

- Fully nail using 3.4 x 35mm square twist nails

**!** DO NOT apply any load to joist prior to RA being fully nailed

#### DECKING INSTALLATION FOR FLOORS

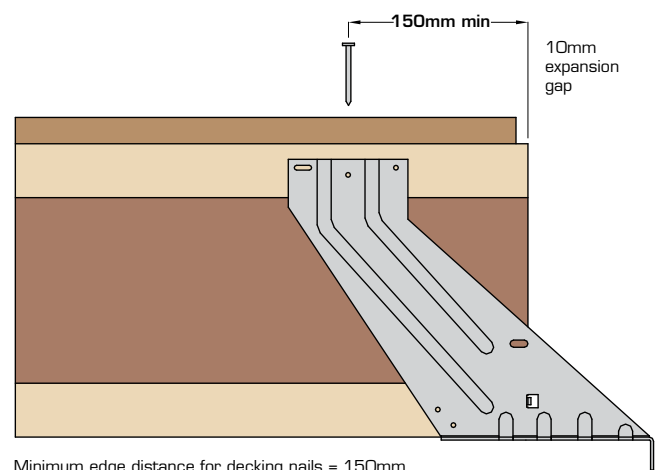

Minimum edge distance for decking nails = 150mm

## Hi-Vis Gripper

Patent Pending

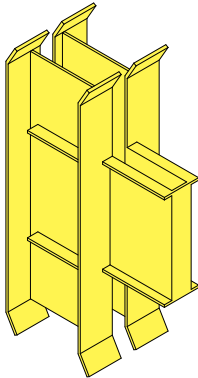

**HV-GR-1**  
38 - 53MM WIDE

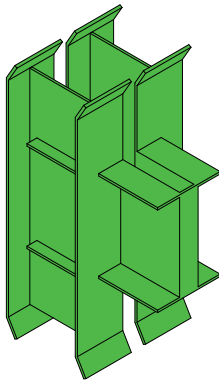

**HV-GR-2**  
58 - 72MM WIDE

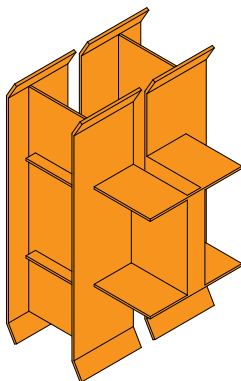

**HV-GR-3**  
89 - 97MM WIDE

The Hi-Vis Gripper is a build-in detail for I-joists into masonry providing an air-tight seal at joist end. The Hi-Vis Gripper can be used on both external and party walls.

### Features & Benefits

- Range of striking colours and unique design enables high visibility for post installation inspection
- Bend and push fit with no mortar to front face speeds up install
- Easy to install - no nailing required or need to trim joists to fit, saving time on site
- Mastic not required to seal I-Joist perimeter, reducing site costs
- Suitable for joists with either 90 or 100mm bearing without protruding into cavity
- A major contribution to compliance with air leakage

### Build-in Detail Advantages

(Requiring external mortar sealing only)

- In line with existing building practice
- Easy access
- Quick and effective
- Visual quality check from outside

### Approvals

- Meets NHBC technical requirements
- Part E: Compliant with the requirements of Appendix A of the Robust Details Part E Handbook
- Assessed to BS ISO-TR12470:1998 for 60 minute fire requirements

### Material Specification

- High density Polyethylene



Additional parallel and perpendicular restraint may be required. Please refer to pages 132 - 133 for further guidance on built in restraint.

### Available Sizes

Joist Manufacturer	Flange Depth (mm)	Joist Depth (mm)	Joist Width (mm)		
			38 - 53	58 - 72	89 - 97
James Jones (JJ)	45	220	HV-GR-220-1	HV-GR-220-2	HV-GR-220-3
		245	HV-GR-240-1	HV-GR-240-2	HV-GR-240-3
		300	HV-GR-300-1	HV-GR-300-2	HV-GR-300-3
Metsawood (FJ)	36 & 39	220	HV-GR-220-1	HV-GR-220-2	HV-GR-220-3
		240	HV-GR-240-1	HV-GR-240-2	HV-GR-240-3
		300	HV-GR-300-1	HV-GR-300-2	HV-GR-300-3
Steico (SJ)	45	220	HV-GR-220-1	HV-GR-220-2	HV-GR-220-3
		240	HV-GR-240-1	HV-GR-240-2	HV-GR-240-3
		300	HV-GR-300-1	HV-GR-300-2	HV-GR-300-3
Masonite (H, HB, HI, HL, HM)	47	220	HV-GR-220-1	HV-GR-220-2	HV-GR-220-3
		240	HV-GR-240-1	HV-GR-240-2	HV-GR-240-3
		300	HV-GR-300-1	HV-GR-300-2	HV-GR-300-3

## Hi-Vis Gripper

### External Wall Application

Install the I-Joists onto the masonry at required centres ensuring that they each have a minimum bearing onto the masonry of 90mm.

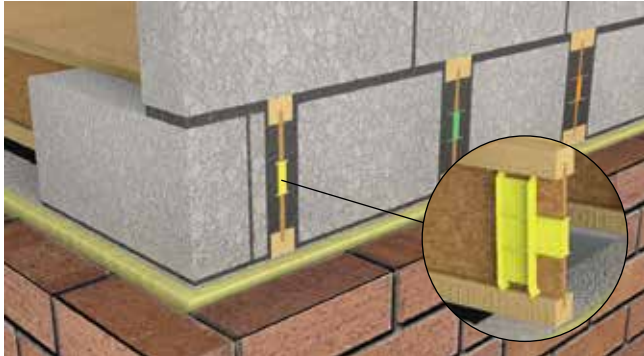

Mortar cavity side to achieve air tightness performance.

### Party Wall Application

Install the I-Joists onto the masonry at required centres ensuring that they each have a minimum bearing onto the masonry of 90mm.

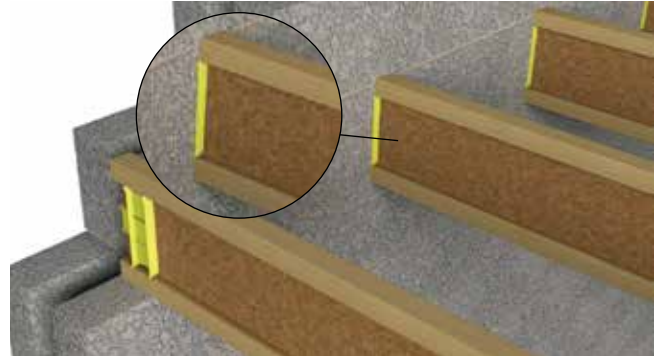

Mortar cavity side to achieve 60 minute Fire Rating and air tightness performance.

### Single Ply

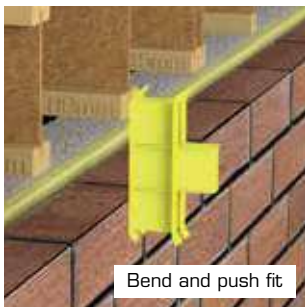

Bend and push fit



Place the Hi-Vis Gripper onto one end of the I-Joist to be built into the masonry. Push fit until it is fully engaged. Ensure it tightly abuts the I-Joist web and that both ends of the Hi-Vis Gripper tightly abut the I-Joist flanges.

### Double Ply



Second Hi-Vis Gripper abuts first to provide an air tight seal.

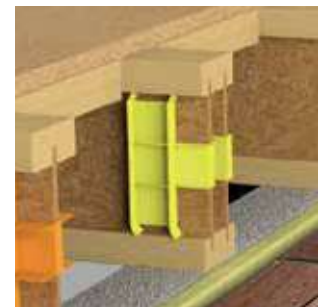

Installation of the Hi-Vis Gripper is now complete.

**!** Double I-Joists must be securely joined with I-Clips.

### Installation Instructions

#### STAGE 1



Install joists and deck as per manufacturer's instructions. Select the correct Hi-Vis Gripper to suit joist width, fold on its easy fold hinges and push onto the end of the joist, no additional fixing required.

#### STAGE 2



Lay mortar bed between joists, add mortar to perp end of block. Install block between joists tight to face of Hi-Vis Gripper.

#### STAGE 3



Add mortar to void created between block, joist and Hi-Vis Gripper and flush up.

#### STAGE 4



Ends of joist can be inspected to ensure correct installation before external brickwork built up.

#### STAGE 5



No mortar or mastic required to internal face. Hi-Vis Grippers visible for post installation inspection prior to plasterboard being installed.

# Timber Frame Overview

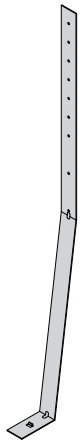

**ST-PFS**  
Page 33

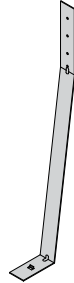

**ST-PFS-M**  
Page 33

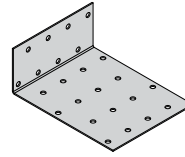

**SP-90**  
Page 34

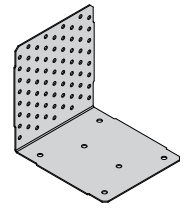

**SP-138**  
Page 34

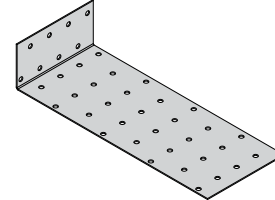

**SP-240**  
Page 34

**TIMBER FRAME HOLDING DOWN STRAPS**

**SOLE PLATE ANCHORS**

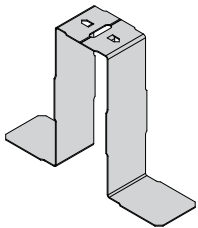

**IR-CLIP**  
Page 35

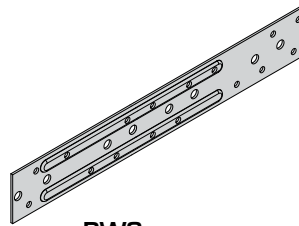
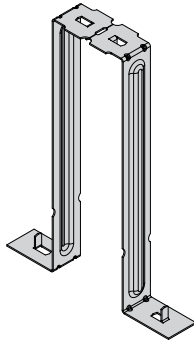

**PWS**  
Page 37

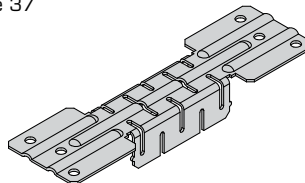

**AWS**  
Page 36



**PSTS**  
Page 38

**INSULATING RETAINING CLIPS**

**PARTY WALL STRAPS**

**OPEN PANEL CONSTRUCTION**

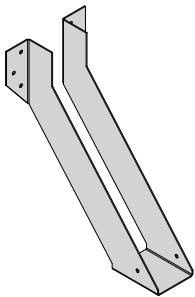

**RD-DCR**  
Page 40

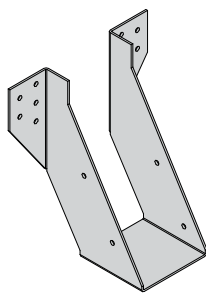

**RD-HDCR**  
Page 41

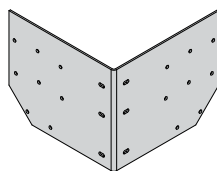

**RD-CDCR**  
Page 42

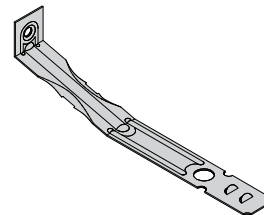

**FT**  
Page 44

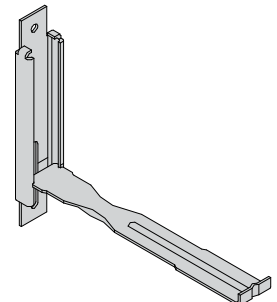

**HMT**  
Page 45

**DISPROPORTIONATE COLLAPSE CONNECTIONS**

**TIMBER FRAME WALL TIES**



# ST-PFS/ST-PFS-M



## Timber Frame Holding Down Strap



The **ST-PFS** and **ST-PFS-M** stainless steel straps are an engineered solution to restrain timber structures against uplift when using either timber joists, engineered joists or concrete ground floors.

### Features & Benefits

- Unique design allows one part to accommodate cavities between 50 - 100mm wide
- Provides unparalleled performance in restraint against uplift to timber frame structures
- Centrally positioned holes minimising any nail slippage or timber splitting

### Material Specification

- Austenitic stainless steel

### Approvals

- Meets NHBC & Homebond technical requirements

### Fixings

Code	Description	Box Qty
547303	3.35 x 50mm Annular Ring Shank Nails	100
547301	3.35 x 50mm Annular Ring Shank Nails	150
547297	3.35 x 50mm Annular Ring Shank Nails	250

100No fixings required for ST-PFS-M bundle

150No fixings required for ST-PFS bundle

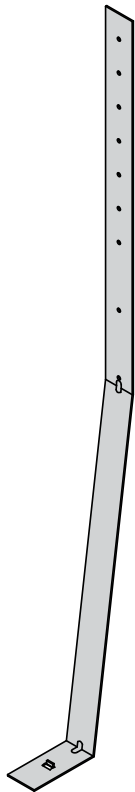

ST-PFS-50-100

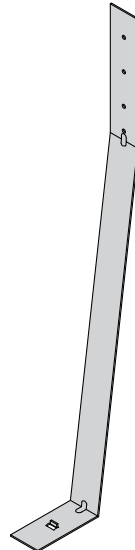

ST-PFS-50-100-M

### In Situ

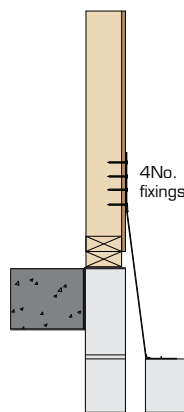
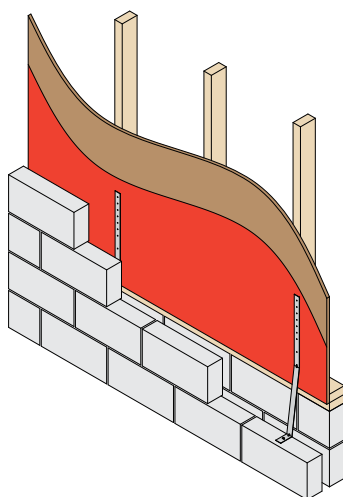

Typical Concrete Ground Floor  
ST-PFS-50-100-M

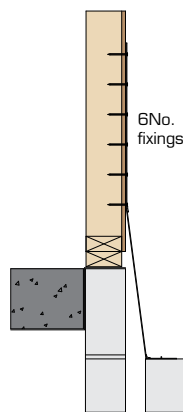

Typical Concrete Ground Floor  
ST-PFS-50-100

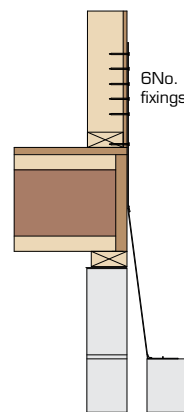

Typical Suspended Ground Floor  
ST-PFS-50-100

### Dimensions (mm)

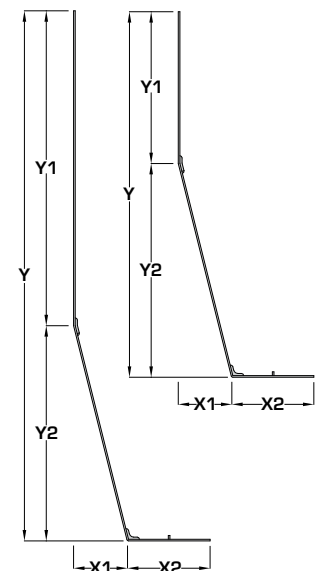

### Load Data

Product Code	Min Cavity Width (mm)	Max Cavity Width (mm)	Fixings (3.35 x 50mm)	Dimensions (mm)					Safe Working Load (kN) Short Term	Characteristic Capacity (kN)
				X1	X2	Y	Y1	Y2		
ST-PFS-50-100	50	100	6	50 - 100	75	722 - 711	346	376 - 365	3.45	6.90
ST-PFS-50-100-M	50	100	4	50 - 100	75	506 - 516	140	376 - 365	2.70	5.40



## Sole Plate Anchor

The **SP** anchor range comprises of **3** anchors to suit various applications. The anchors are designed to locate and anchor timber sole plates.

### Features & Benefits

- Multiple nail holes offering various nailing options
- Provides secure location without puncturing the DPC

### Material Specification

- Galvanised mild steel - Z275

### Fixings

Fixings to be specified by Building Designer

### In Situ

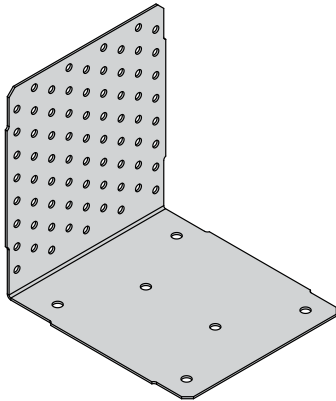
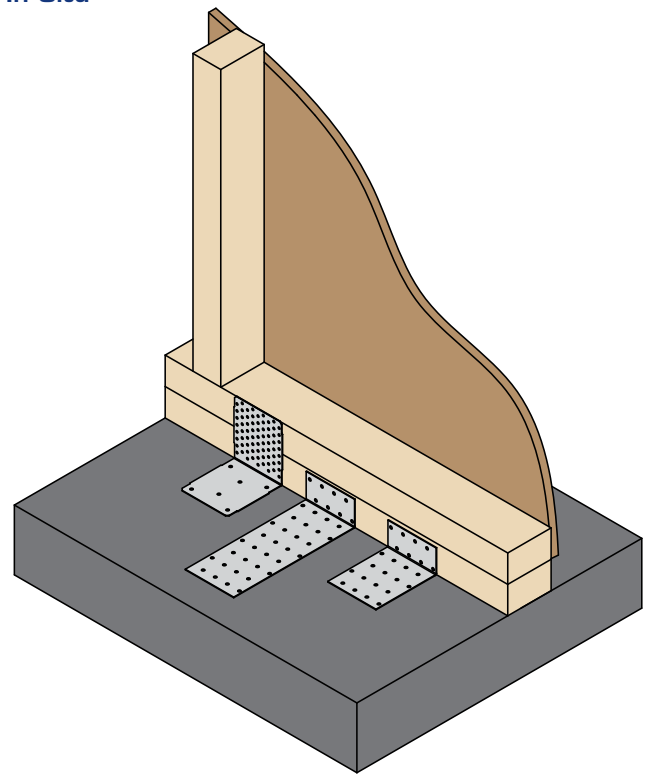

SP-90

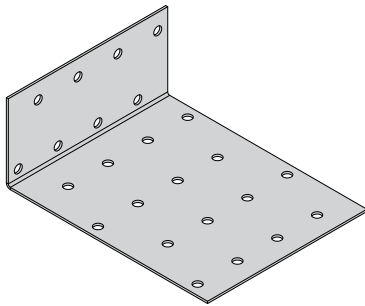

SP-138

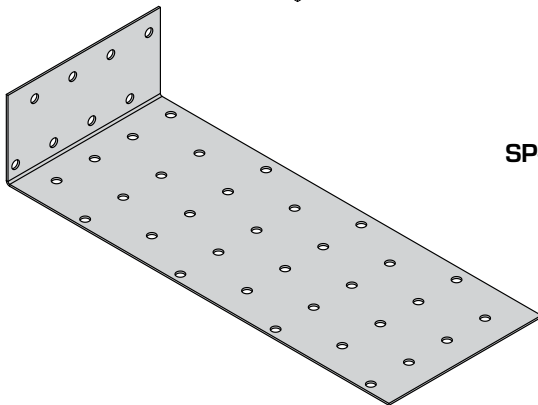

SP-240

### Dimensions (mm)

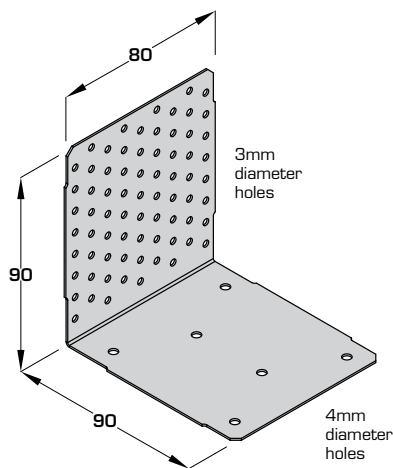

SP-90

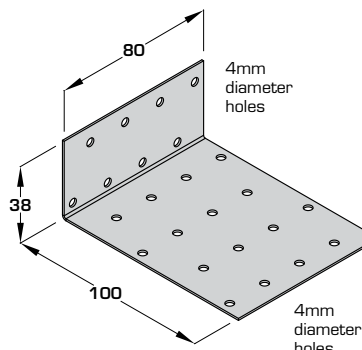

SP-138

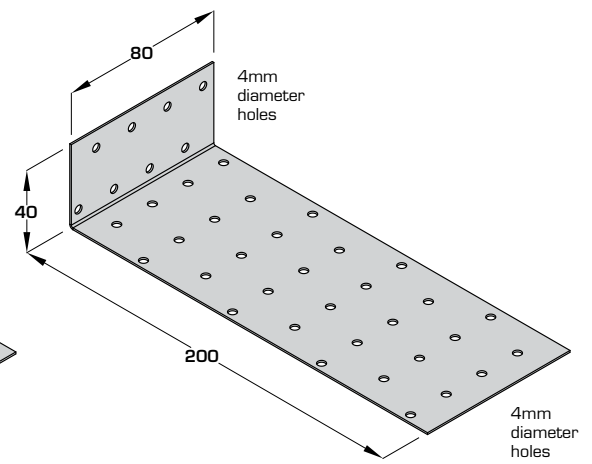

SP-240

## Insulation Retaining Clip

The IR-Clip allows for the use of high performance rigid insulation within a timber frame panel, whilst maintaining a service gap.

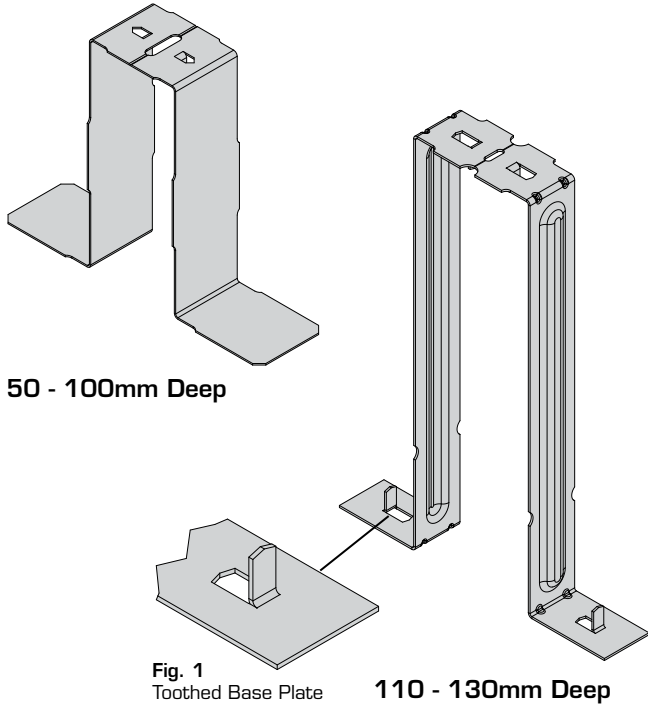

Fig. 1  
Toothed Base Plate

### Available Sizes

Product Code	Height (H) (mm)
IR-Clip-50	50
IR-Clip-70	70
IR-Clip-100	100
IR-Clip-110	110
IR-Clip-120	120
IR-Clip-130	130

### Features & Benefits

- Snap-off detail splits the IR-Clip into two halves, for use on multiple studs or single use applications i.e panel ends
- Speeds up panel manufacturing time, as insulation and OSB can be fitted from the same side
- Toothed profile to allow easy installation with no nails or screws required
- Guaranteed service void (2No IR-Clips can be used to create two void areas within a panel)

### Material Specification

- Galvanised mild steel - Z275

### Dimensions (mm)

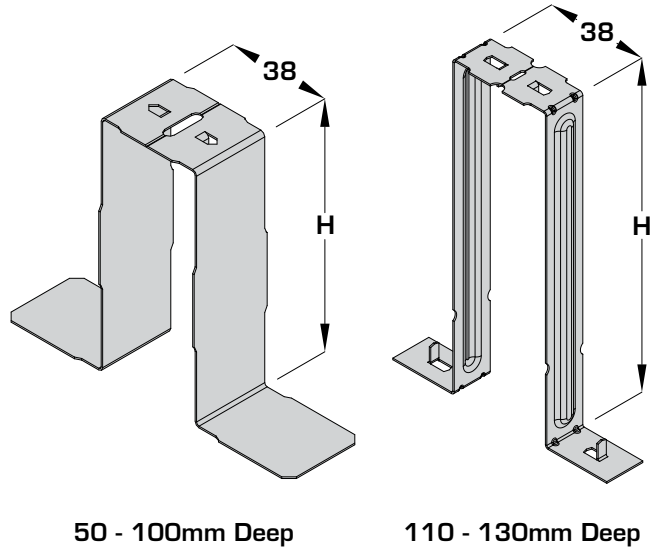

### In Situ

Quantity required to be confirmed by Building Designer / Manufacturer (Non Structural item)

Single Stud Application:

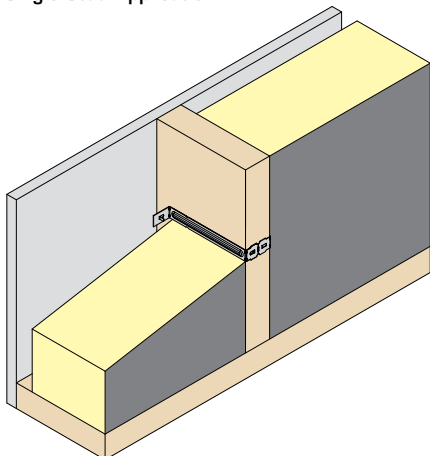

Double Stud Application:

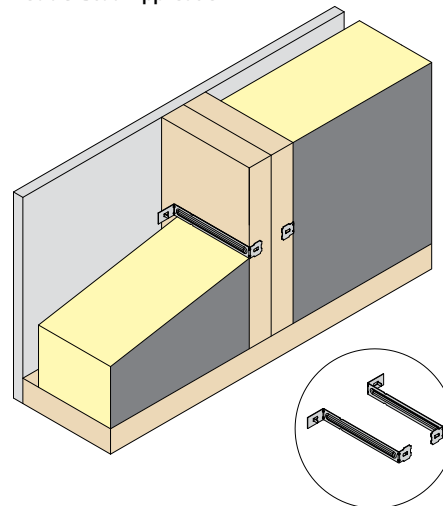

## Acoustic Wall Strap

GB Patent: 2448765



The AWS wall straps are used to connect separating walls in attached dwellings.

### Features & Benefits

- Special design allows for greater strength and acoustic properties over standard straps
- Ensures correct cavity width, eliminating site errors
- Increased compression and tension strength enabling greater transfer of wind loadings
- Unique slotted profile reduces sound transmission

### Material Specification

- Galvanised mild steel - Z275

### Approvals

- Compliant with Part E (England & Wales) - Part E & Approved Document E
- Compliant with Part E (Ireland)
- Compliant with E-WT-1 & E-WT-2 (Robust Details) for separating wall straps
- Compliant with Building Standards Scotland - Section 5 (Noise)
- Compliant with Regulation G2 Northern Ireland - DOE Technical Booklet G

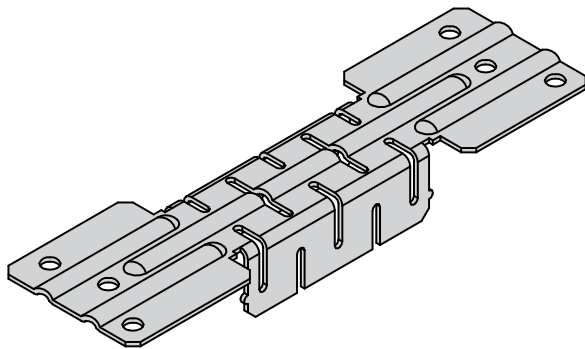

Timber Frame

### In Situ

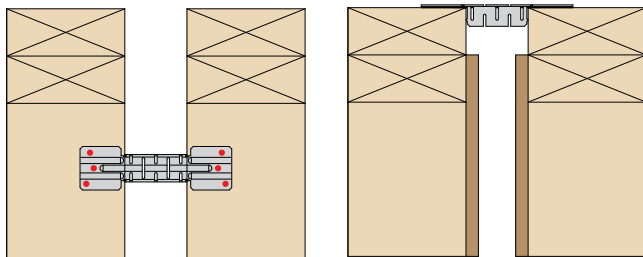

#### E-WT-1 (timber frame cavity wall without sheathing)

AWS fixed to face of panel.

Straps at 1200mm (min) centres horizontally, one row of ties per storey height vertically.

To be positioned near top of panel.

#### E-WT-2 (timber frame cavity wall with sheathing)

AWS fixed to top rail.

Straps at 1200mm (min) centres horizontally, one row of ties per storey height vertically.

When levels change straps should be fixed to the face of the panel.

### Fixings

Code	Description	Box Qty
547389	3.4 x 35mm Square Twist Nails - LOOSE	500
141185	3.4 x 35mm Square Twist Nails - COLLATED*	2,500

\*For use with Paslode PPN35Ci

### Dimensions (mm)

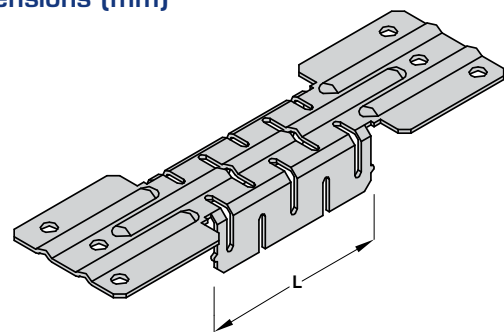

### Load Data

Product Code	L (mm)	Cavity Width (mm)	Fixings (3.4 x 35mm)	Safe Working Load (kN) Compression & Tension Short Term	Characteristic Capacity (kN) Compression & Tension**
AWS-50	50	50	6	1.70	3.20
AWS-65	65	65	6	1.70	3.20

\*\*Values obtained from tests carried out by ITW Construction Products and calculated in accordance with ETAG 015.

## Party Wall Strap



The **PWS** wall straps are used to connect separating walls in attached dwellings.

### Features & Benefits

- 2 parts can accommodate cavity widths from 50 - 100mm

### Material Specification

- Galvanised mild steel - Z275

### Approvals

- Compliant with Part E (England & Wales) - Part E & Approved Document E
- Compliant with Part E (Ireland)
- Compliant with E-WT-1 & E-WT-2 (Robust Details) for separating wall straps
- Compliant with Building Standards Scotland - Section 5 (Noise)
- Compliant with Regulation G2 Northern Ireland - DOE Technical Booklet G

PWS-200

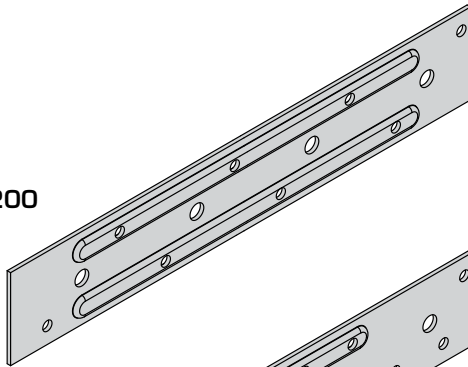

PWS-240

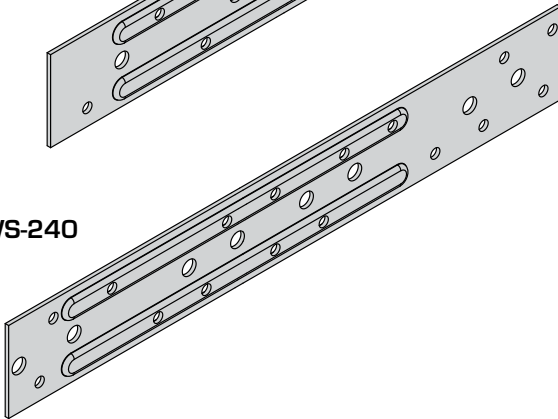

### In Situ

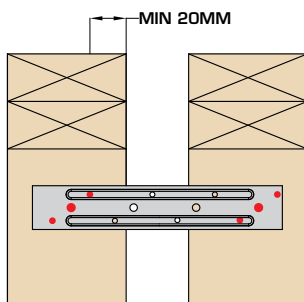

#### E-WT-1 (timber frame cavity wall without sheathing)

PWS fixed to face of panel.

Straps at 1200mm (min) centres horizontally, one row of ties per storey height vertically.

To be positioned near top of panel.

Nails to have minimum 20mm edge distance.

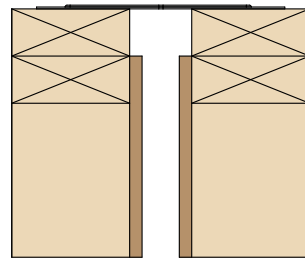

#### E-WT-2 (timber frame cavity wall with sheathing)

PWS fixed to top rail.

Straps at 1200mm (min) centres horizontally, one row of ties per storey height vertically.

When levels change straps should be fixed to the face of the panel.

Nails to have minimum 20mm edge distance.

### Fixings

Code	Description	Box Qty
547389	3.4 x 35mm Square Twist Nails - LOOSE	500
141185	3.4 x 35mm Square Twist Nails - COLLATED*	2,500

\*For use with Paslode PPN35Ci

### Dimensions (mm)

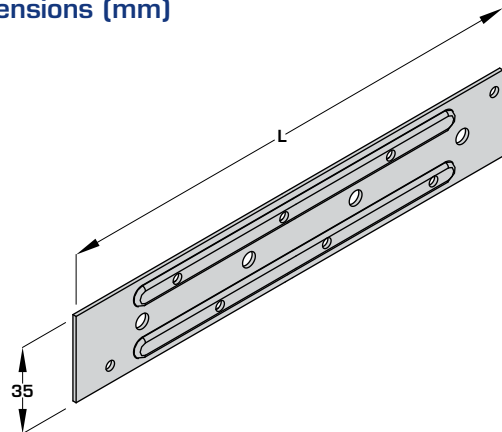

### Load Data

Product Code	L (mm)	Cavity Width (mm)	Fixings (3.4 x 35mm)	Safe Working Load (kN) Compression & Tension Short Term	Characteristic Capacity (kN) Compression & Tension
PWS-200	200	50 - 75	6	1.70	2.70
PWS-240	240	76 - 100	6	1.20	1.70

## Open Panel Connection (8mm)



**CE**  
EN 4592

The Paslode Structural Screws are specifically designed for the UK Construction market. The 8mm diameter screws can quickly and easily join timber frame panels together.

### Features & Benefits

- Draws panels tightly together to maximise strength and minimise air leakage
- Higher lateral load capacity than nails or conventional screws
- Suitable for Service Class 2

### Available Sizes For Application

Code	Reference	Description	Box Qty
551110	PSTS8.0x65	Structural Timber Screw 8.0 x 65mm Hex Head	100
551103	PSTS8.0x85	Structural Timber Screw 8.0 x 85mm Hex Head	100

### Dimensions (mm)

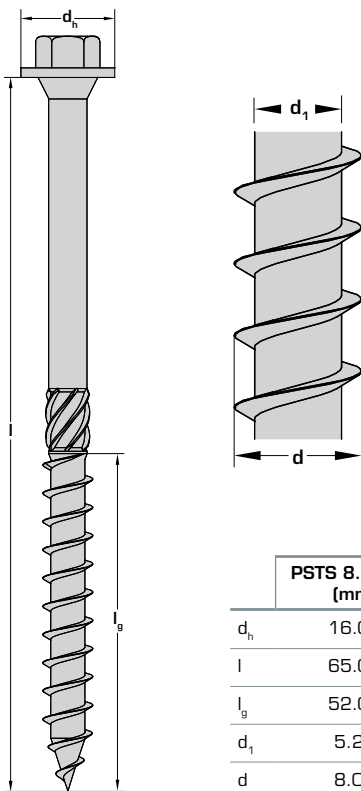

	PSTS 8.0 x 65 (mm)	PSTS 8.0 x 85 (mm)
$d_h$	16.00	16.00
$l$	65.00	85.00
$l_g$	52.00	52.00
$d_1$	5.25	5.25
$d$	8.00	8.00

### In Situ

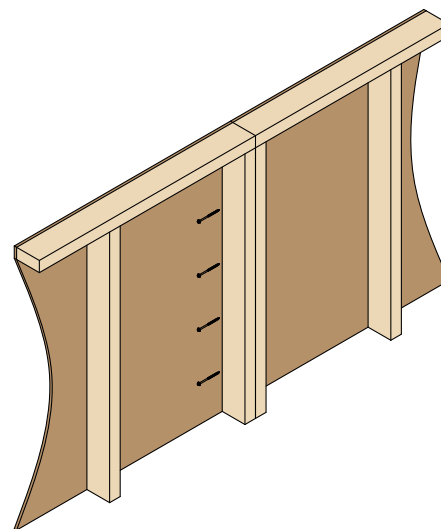

PSTS to be fixed at panel joints to engineer's specification.

PSTS can be fixed from both sides.

Once installed panels will be drawn tightly together to maximise strength and minimise air leakage.

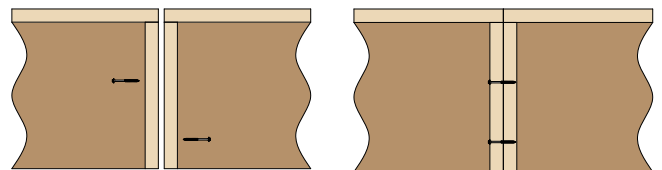

### Load Data

Thickness of Each Member (mm)	Length of Fastener (mm)	Long-Term Permissible Lateral Load-Carrying Capacity (kN) of 2 Member Joints Made From			Characteristic Lateral Load-Carrying Capacity (kN) of 2 Member Joints Made From		
		C16	C24	TR26	C16	C24	TR26
35	65	0.74	0.84	0.88	1.78	1.99	2.07
38	65	0.70	0.79	0.84	1.68	1.86	1.99
45	85	0.97	1.10	1.16	2.37	2.65	2.75
47	85	0.98	1.10	1.17	2.34	2.62	2.72

# Disproportionate Collapse



## Product Overview

The RD-Range was developed for joist to rim beam connections. The design concept is that the floors are constructed as normal with the joists bearing onto the wall panel and the RD-DCR is then fixed into position to restrain the joist. In the event of a disproportionate collapse situation arising (fire, explosion etc) the RD-DCR will act as a hanger to transfer the floor load to the rim beam which will have been designed to carry this load across the length of the panels.

The disproportionate collapse restraint system (RD range) is a multi-compliant solution that meets:

- Part A: Compliant with Disproportionate Collapse requirements for 5 storeys or more
- Part E: Compliant with Robust Details (E-FT-1 and E-FT-2) for timber frame structural junctions between timber separating floors and external walls
- Part E: Assisting towards compliance for Approved Document E performance requirements
- Corner bracket system makes a minor contribution to compliance with air leakage
- Building Standards (Scotland) - Section 1.2 (Structure) and 5.1 (Noise)

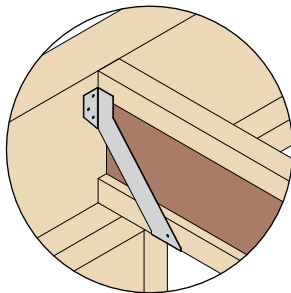

RD-DCR

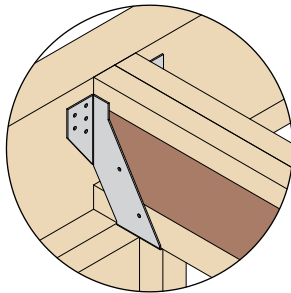

RD-HDCR

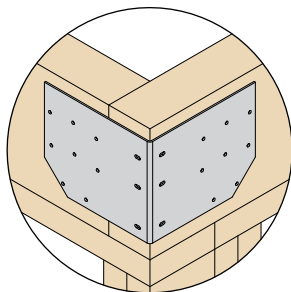

RD-CDCR

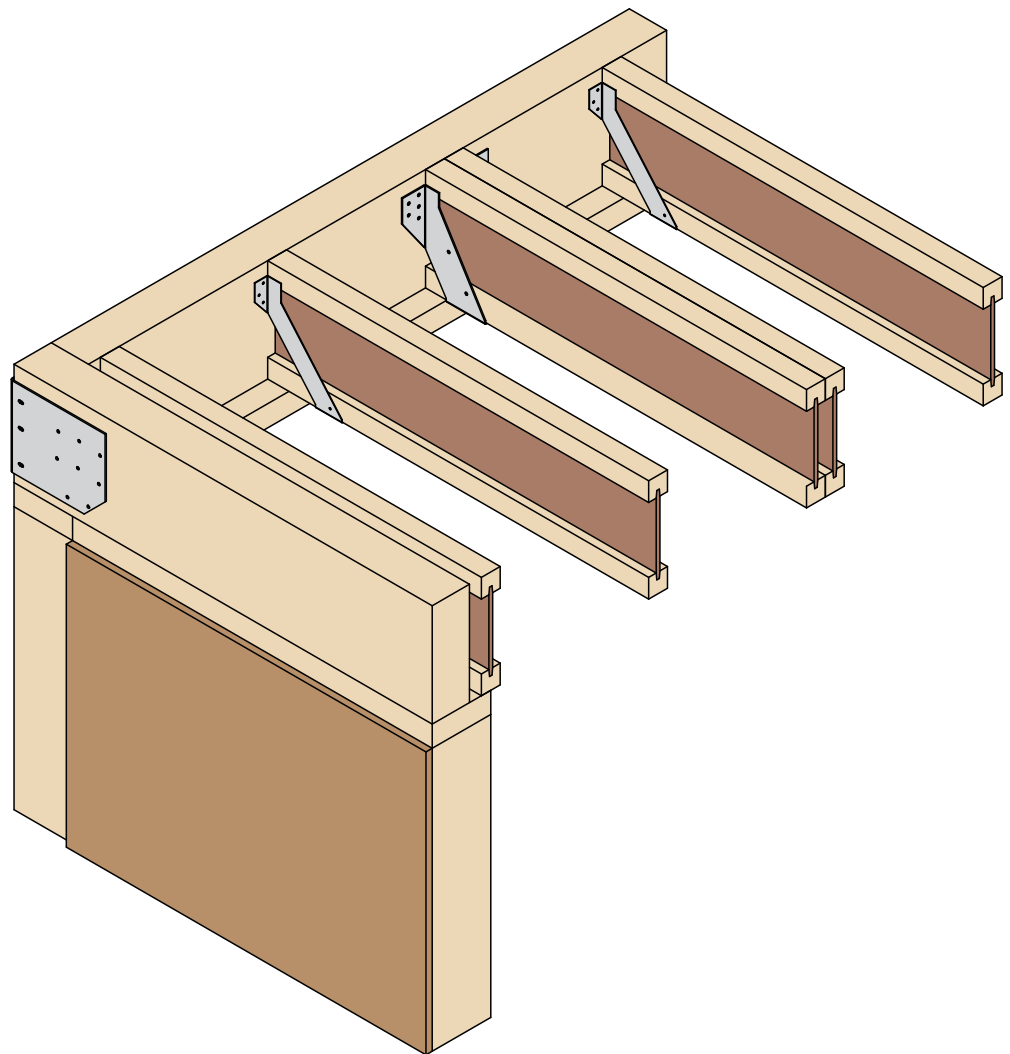

The RD Range is only applicable in cases where the joists are permanently supported on the timber frame wall panels. It must not be used as a supporting hanger.

## Disproportionate Collapse Restraint

The RD-DCR hanger is a disproportionate collapse restraint for supporting internal beams onto the rim beam. It allows the internal beam to bear onto the timber frame panel below and fix to the rim beam, enabling the restraint to comply with disproportionate collapse requirements.

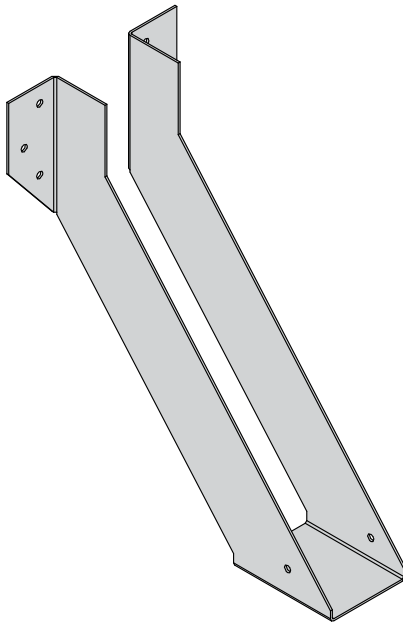

### Features & Benefits

- Permits increased standardisation of details for all storey heights
- Improves low frequency sound insulation performance
- Improves stiffness of the floor

### Approvals

- Allows timber separating floor to comply with sound insulation requirements of Robust Details for Part E (RD Handbook E-FT-1 and E-FT-2) for all storey heights
- Complies with Part A disproportionate collapse requirements

### Material Specification

- Galvanised mild steel - Z275

### Fixings

Code	Description	Box Qty
547389	3.4 x 35mm Square Twist Nails - LOOSE	500
141189	3.4 x 35mm Square Twist Nails - COLLATED*	1,250

\*For use with Paslode PPN35C

### Dimensions (mm)

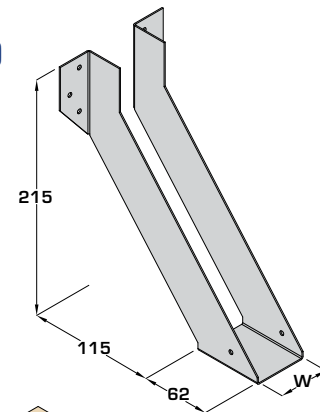

### In Situ

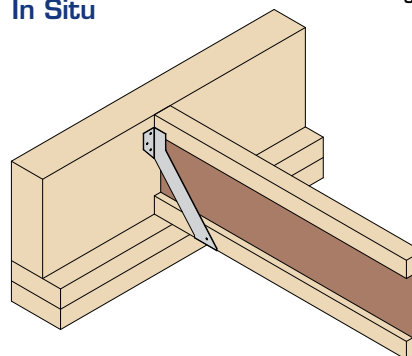

Once joist is in place and abutting rim beam the RD-DCR is put in place from the underside and fully nailed.

### Available Sizes

Product Code	Joist Depth (mm)**	
	Min	Max
RD-DCR-39-215	220	304
RD-DCR-46-215	220	304
RD-DCR-50-215	220	304
RD-DCR-55-215	220	304
RD-DCR-61-215	220	304
RD-DCR-65-215	220	304
RD-DCR-72-215	220	304
RD-DCR-75-215	220	304
RD-DCR-78-215	220	304
RD-DCR-92-215	220	304
RD-DCR-100-215	220	304

\*\*Web stiffeners required for 300mm deep I-Joists.

### Load Data

Hanger Depth (H) (mm)	Fixings (3.4 x 35mm)		Accidental Safe Working Load (kN)	Characteristic Capacity (kN)***
	Header	Incoming		
215	6	2	5.40	5.61

\*\*\*Values obtained from tests carried out by ITW Construction Products and calculated in accordance with ETAG 015



## Heavy Disproportionate Collapse Restraint

The RD-HDCR hanger is a high load disproportionate collapse restraint for supporting internal beams onto the rim beam. It allows the internal beam to bear onto the timber frame panel below and fix to the rim beam, thus enabling the restraint to comply with disproportionate collapse requirements.

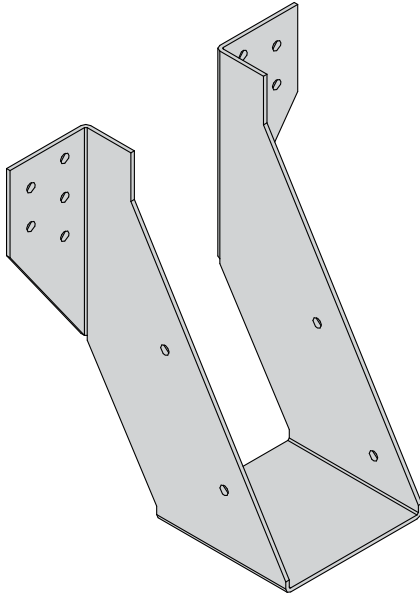

### Features & Benefits

- Permits increased standardisation of details for all storey heights
- Improves low frequency sound insulation performance
- Improves stiffness of the floor

### Approvals

- Allows timber separating floor to comply with sound insulation requirements of Robust Details for Part E (RD Handbook E-FT-1 and E-FT-2) for all storey heights
- Complies with Part A disproportionate collapse requirements

### Material Specification

- Galvanised mild steel - Z275

### Fixings

14No Paslode PSTS 6.5 x 35mm supplied with hanger

### Dimensions (mm)

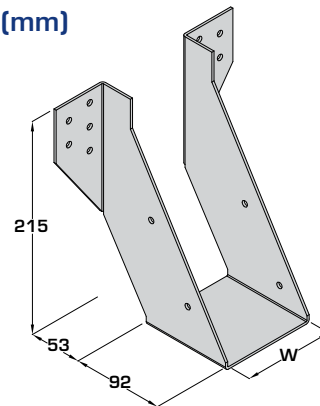

### Available Sizes

Product Code	Joist Depth (mm)**	
	Min	Max
RD-HDCR-39-215	220	304
RD-HDCR-46-215	220	304
RD-HDCR-50-215	220	304
RD-HDCR-55-215	220	304
RD-HDCR-61-215	220	304
RD-HDCR-65-215	220	304
RD-HDCR-72-215	220	304
RD-HDCR-75-215	220	304
RD-HDCR-78-215	220	304
RD-HDCR-92-215	220	304
RD-HDCR-100-215	220	304
RD-HDCR-110-215	220	304
RD-HDCR-122-215	220	304
RD-HDCR-130-215	220	304
RD-HDCR-144-215	220	304
RD-HDCR-150-215	220	304
RD-HDCR-183-215	220	304
RD-HDCR-198-215	220	304

\*\*Web stiffeners required for I-Joists and double end blocks required for Open Web Joists

### In Situ

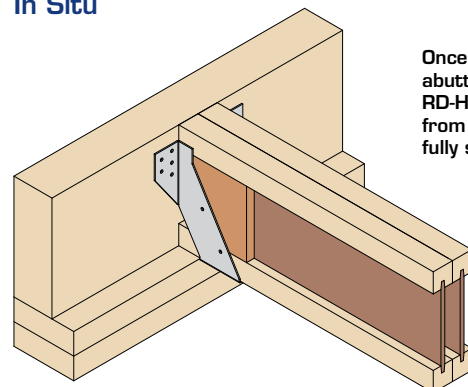

Once joist is in place and abutting rim beam the RD-HDCR is put in place from the underside and fully screwed.

### Load Data

Hanger Depth (H) (mm)	Fixings (PSTS 6.5 x 35mm)		Accidental Safe Working Load (kN)	Characteristic Capacity (kN)***
	Header	Incoming		
215	10	4	25.00	25.00

\*\*\*Values obtained from tests carried out by ITW Construction Products and calculated in accordance with ETAG 015

# RD-CDCR



## Corner Disproportionate Collapse Restraint

The RD-CDCR hanger is a disproportionate collapse detail for connecting rim beams at corner junctions.

### Features & Benefits

- Face fixed corner bracket with high load connection avoids base plate compromising air tightness of the rim beam
- One bracket to suit all joist depths

### Material Specification

- Galvanised mild steel - Z275

### Fixings

16No Paslode PSTS 6.5 x 35mm supplied with hanger  
3No Paslode PSTS 6.5 x 115mm supplied with hanger

### Dimensions (mm)

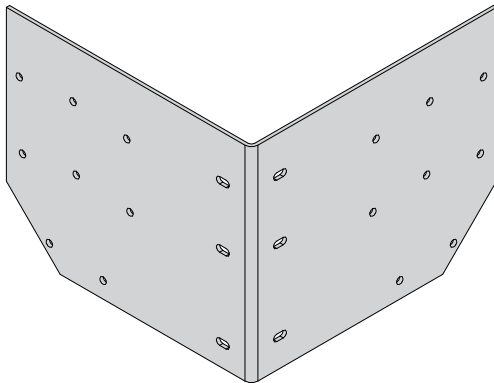
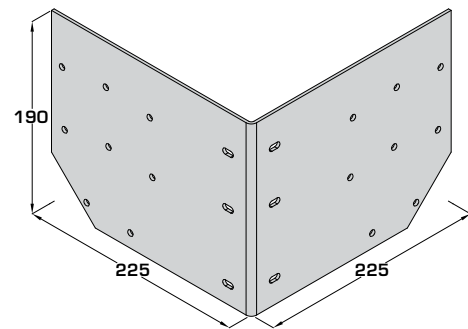

### In Situ

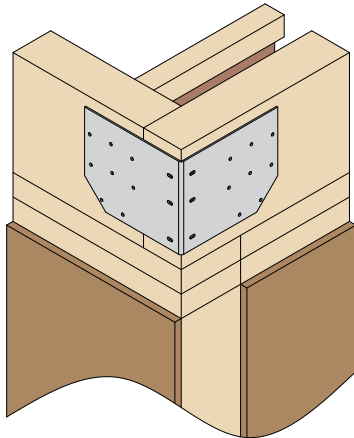

### Installation

Suitable for 45mm and 90mm rim beams as shown in installations below.

150mm long screws are required when installing 90mm rim beams.

Code	Description	Box Qty
551107	PSTS 6.5 x 150	100

Contact Technical Support to discuss other applications.

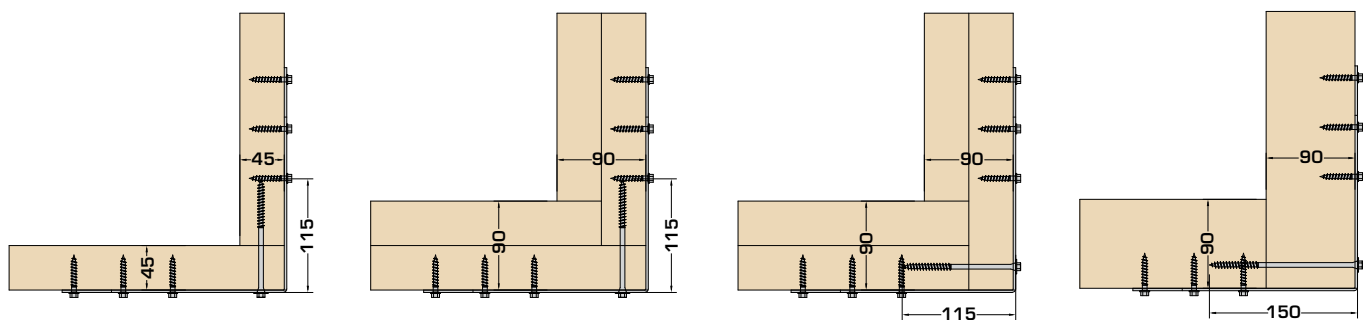

### Load Data

Product Code	Joist Depth (mm)		Fixings		Accidental Safe Working Load (kN)	Characteristic Capacity (kN)*
	Min	Max	PSTS 6.5 x 35mm	PSTS 6.5 x 115mm		
RD-CDCR	220	304	16	3	25.00	25.00

\*Values obtained from tests carried out by ITW Construction Products and calculated in accordance with ETAG 015

# Timber Frame Wall Ties



## Differential Movement in Timber Frame

New Requirements (Build Type)		Vertical Movement Allowed (mm)	Solution
Solid timber joists	2 storey	20	FT
	3 storey and above	35+	HMT
EWP joists	2 storey	15	FT
	3 storey	25	FT
	4 storey and above	35 - 60	HMT

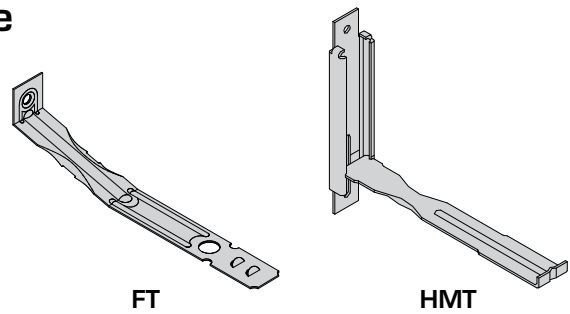

Cullen standard wall ties FT-50, 75 & 100 accommodate maximum differential movement of 25mm and therefore can be used up to eaves level on a 2 storey for solid timber joists and up to 3 storey for EWP joist floors. For 3 storey solid timber joists and 4 storey EWP joists you will now require the Cullen High Movement Tie (HMT).

Previously, the old requirements stated 6mm movement per floor and allowed the FT range to be used for 4-storey buildings. The HMT is the only timber to masonry wall tie which has been fully tested to allow for 75mm vertical movement. Under the new guidelines this would allow the HMT to be used on 7 storey timber frame with EWP joists on the intermediate floors.

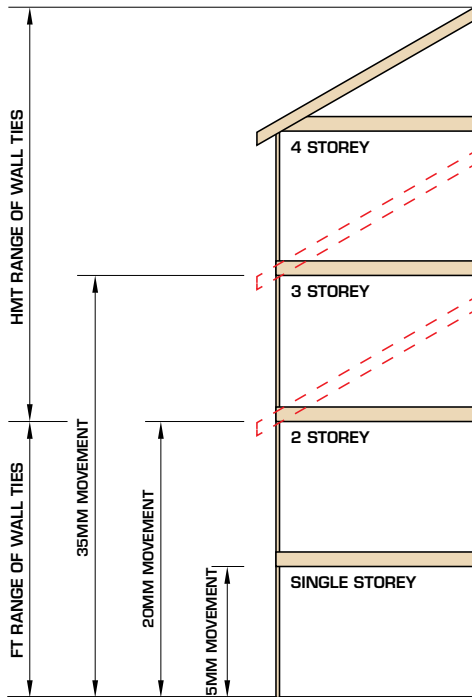

INTERMEDIATE FLOORS CONSTRUCTED USING SOLID TIMBER JOISTS

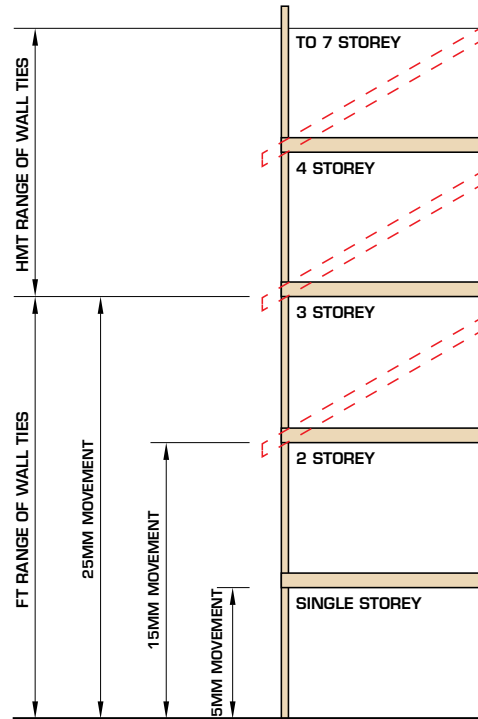

INTERMEDIATE FLOORS CONSTRUCTED USING EWP JOISTS

The above information is for guidance only, it states the maximum allowed movement of the Cullen timber frame wall tie range. For specific tie fixings please refer to the Building Engineer and/or section 6.2 of NHBC standards.

Gap Location	W	Gap sizes Closing Gap (CG) at window sills level and Opening (OG) at windows head levels	
		Joist Material	
		Solid Timber (mm)	Engineered I-Joist (mm)
Bottom level (single storey)	A	5	5
Level 1 (2 storey)	B	20	15
Level 2 (3 storey)	C	35	25
Level 1 (4 storey)	D	45	35
Level 4 (5 storey)	E	45	45
Level 5 (6 storey)	F	Specialist calculation to be submitted to NHBC	53
Level 6 (7 storey)	G	Specialist calculation to be submitted to NHBC	61
Eaves / verge		Add 5mm to level below	

## Timber Frame / SIPs Wall Tie

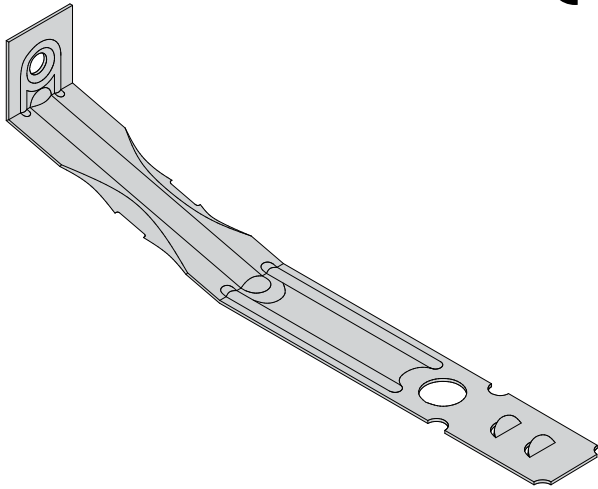

The FT wall ties are used to restrain the external blockwork/brickwork back to the timber frame structure.

### Features & Benefits

- Accommodates maximum differential movement of 24mm
- Available to suit up to 115mm wide cavities

### Material Specification

- Austenitic stainless steel

### Approvals

- CE marked and tested in accordance with BS EN 845-1
- Meets NHBC & Homebond technical requirements

### Fixings

3.35 x 50mm annular ring shank nails supplied with part

Code	Description	Box Qty
114386	5.0 x 25mm Pozidrive Stainless Steel Screws	200

### In Situ

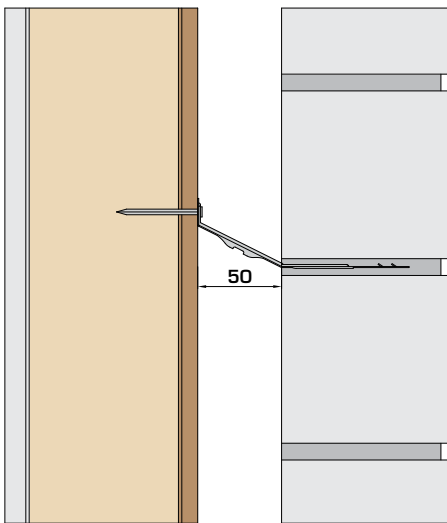

- Maximum horizontal expansion of 1.4mm on a 50mm cavity
- Additional ties are required at door and window openings (Spacing should be no more than 300mm vertical centres and within 225mm of the jambs at openings)
- Top row of ties should be 3 courses below top of brickwork
- Spacing also required at each side of vertical expansion joints
- Closer vertical spacing may be required in exposed locations as determined by the Building Designer

### Dimensions (mm)

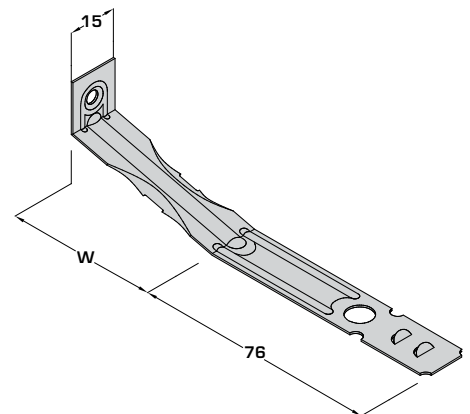

### Load Data

Product Code	W (mm)	Min Cavity Width (mm)	Max Cavity Width (mm)	Fixings (3.35 x 50mm ARS) For Timber Frame	Characteristic Capacity @1mm Movement (N)*		Characteristic Capacity (N)**	
					Tension	Compression	Tension	Compression
FT-50	50	50	65	1	205	270	615	446
FT-75	75	75	90	1	205	270	615	446
FT-100	100	100	115	1	205	270	615	446
				Fixings (5.0 x 25mm Stainless Steel Screws) For SIPs				
FT-50	50	50	65	1	260	270	780	446
FT-75	75	75	90	1	260	270	780	446
FT-100	100	100	115	1	260	270	780	446

\*Figures to be used when calculating wall ties to BS 5268-2:2006

\*\* Ultimate load failure - Figures to be used when calculating wall ties to EC5, duration factors and kmod factors to be applied

## High Movement Timber Frame Wall Tie

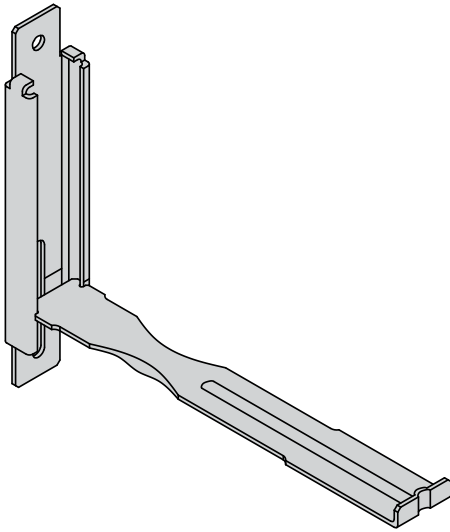

The HMT wall ties are used to restrain the external blockwork/brickwork back to the timber framed structure. They provide greater performance to accommodate differential movement in medium to high-rise structures.

### Features & Benefits

- Accommodates maximum differential movement of 75mm

### Material Specification

- Austenitic stainless steel

### Approvals

- CE marked & tested in accordance with BS EN 845-1
- Meets NHBC & Homebond technical requirements

### Fixings

- 3.35 x 50mm annular ring shank nails supplied with part

### Dimensions (mm)

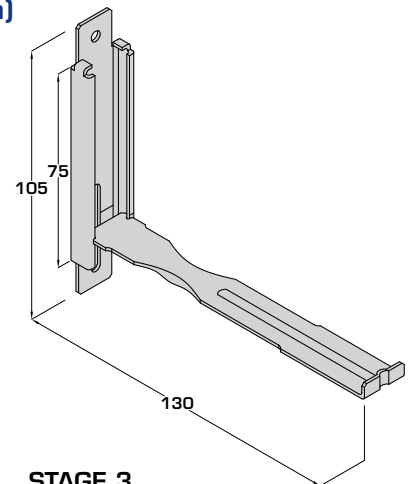

### In Situ

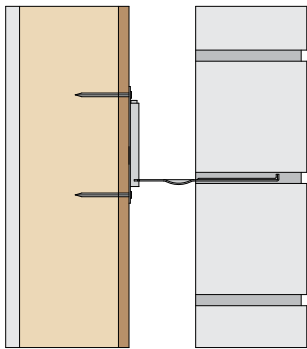

### Installation Instructions

#### STAGE 1

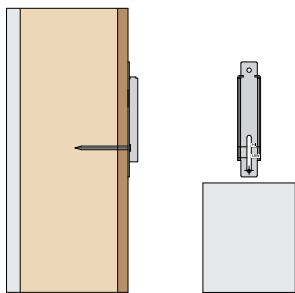

Nail channel into wall panel by nailing 1No fixing at the bottom of the slot. Allow adequate space above the masonry to hammer fix.

#### STAGE 2

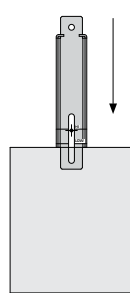

Position channel by lightly tapping with a hammer until channel is in correct position.

The tie should line through with the LOW marker to allow full 75mm movement.

#### STAGE 3

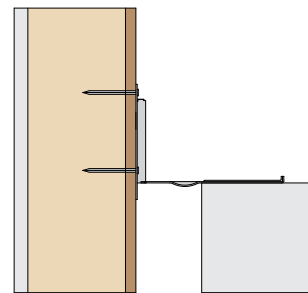

Once the channel is in position fix the top round hole into the wall panel, position the tie and build the next course of block work.

LOW - 75mm movement  
HIGH - 65mm movement

### Load Data

Product Code	Min Cavity Width (mm)	Max Cavity Width (mm)	Fixings (3.35 x 50mm ARS) For Timber Frame	Characteristic Capacity @ 1mm Movement (N)*		Characteristic Capacity (N) **	
				Tension	Compression	Tension	Compression
HMT-50	50	65	2	295	475	826	1021

\*Figures to be used when calculating wall ties to BS 5268-2:2006

\*\*Ultimate load failure - Figures to be used when calculating wall ties to EC5, duration factors and kmod factors to be applied

## I-JOIST APPLICATIONS

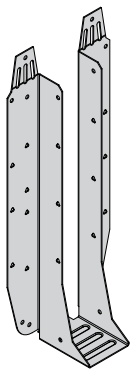

(39 - 100mm wide)

**UH**

Pages 49 - 56

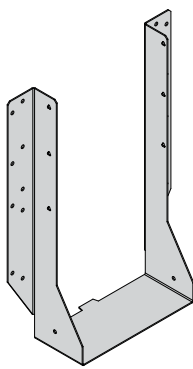

(39 - 198mm wide)

**FFI**

Pages 63 - 66

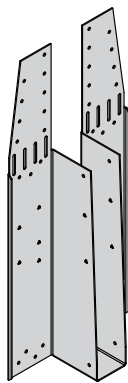

**HUH**

Pages 67 - 70

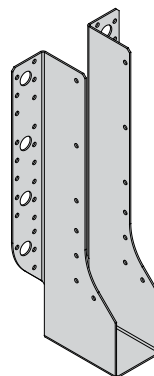

**MHE**

Pages 80 - 81

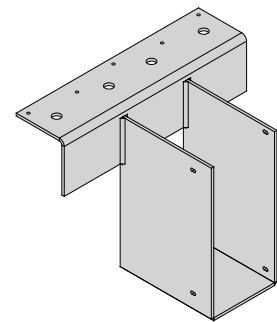

**FTHI**

Page 83

**STANDARD**

**HIGH LOAD**

**VERY HIGH LOAD**

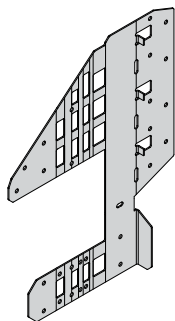

(39 - 100mm wide)

**VRC**

Pages 86 - 87

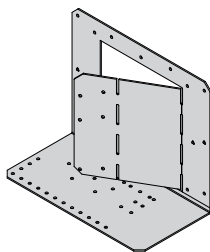

(39 - 100mm wide)

**VS**

Pages 84 - 85

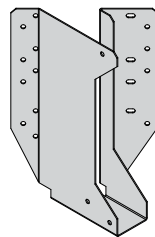

(39 - 100mm wide)

**45L/R**

Page 89

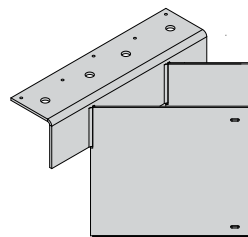

(39 - 300mm wide)

**FTHIS**

Page 83

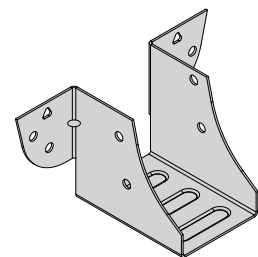

**KM**

Page 82

**SLOPED\* & SKEWED**

(\*VRC ONLY)

**MINI**

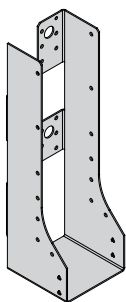

(39 - 78mm wide)

**MHIC**

Pages 80 - 81

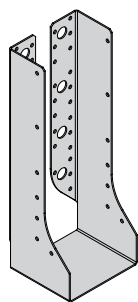

(92 - 300mm wide)

**MHI**

Pages 80 - 81

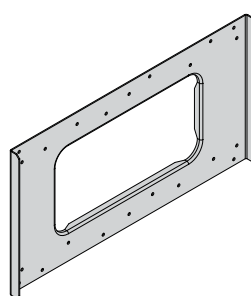

**SHI**

Page 101

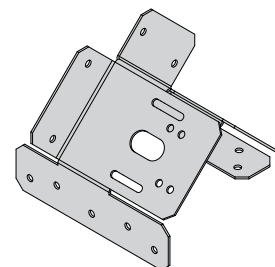

**ACE**

Page 88

**INTERNAL FLANGE**

**SERVICE HOLE PLATE**

**RAFTER / WALL PLATE**

# EWP Timber Hanger Overview



## OPEN WEB APPLICATIONS

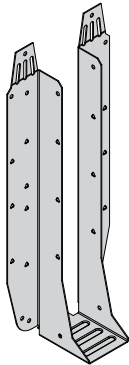

(39 - 100mm wide)

**UH**

Pages 57 - 62

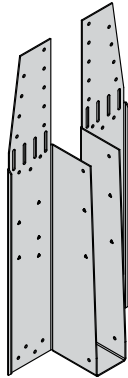

**HUH**

Pages 71 - 77

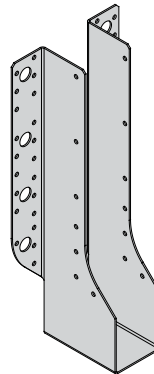

**MHE**

Pages 80 - 81

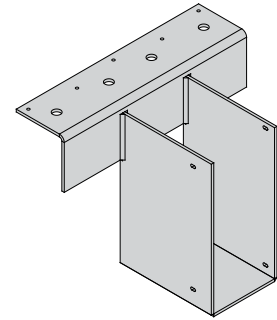

**FTHI**

Page 83

**STANDARD**

**HIGH LOAD**

**VERY HIGH LOAD**

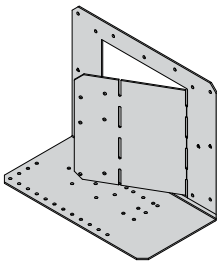

(39 - 100mm wide)

**VS**

Pages 84 - 85

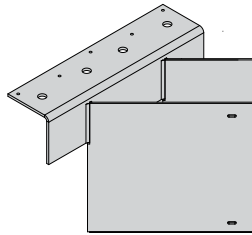

(39 - 300mm wide)

**FTHIS**

Page 83

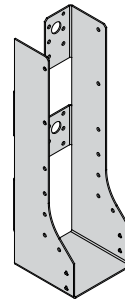

(39 - 78mm wide)

**MHIC**

Pages 80 - 81

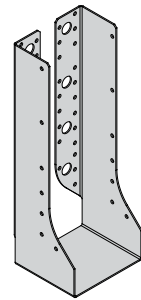

(92 - 300mm wide)

**MHI**

Pages 80 - 81

**SKEWED**

**INTERNAL FLANGE**

## ANCILLARY PRODUCTS

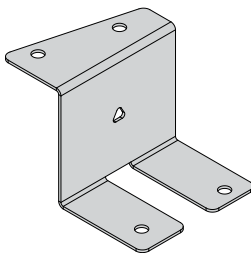

**UZ-CLIP**

Pages 90 - 91

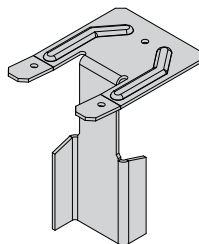

**OW-CLIP**

Pages 94 - 95

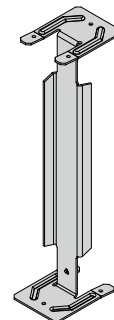

**I-CLIP**

Pages 92 - 93



**PSTS**

Pages 96 - 100

**NOGGIN SUPPORT**

**MULTIPLE CONNECTIONS**

## UH - QUICK REFERENCE GUIDE

Hanger	Header	SWL (kN)											
		1	2	3	4	5	6	7	8	9	10	11	12
	I-Joist Without Backer / Top Tabs Removed	3.50kN											
	I-Joist Without Backer	4.50 - 4.83kN											
	I-Joist With Backer	7.13 - 10.23kN											
UH	Open Web / Top Tabs Removed	3 - 3.50kN											
	Open Web	5.80kN											
	Open Web With Plywood Gusset	7.13 - 8.12kN											
	Glulam (Min GL28)	7.13 - 8.12kN											
	LVL	10.24 - 11.97kN											

Hanger	Header	Characteristic Capacity (kN)																						
		1	2	3	4	5	6	7	8	9	10	11	12	13	14	15	16	17	18	19	20	21	22	23
	I-Joist Without Backer / Top Tabs Removed	7.43 - 7.83kN																						
	I-Joist Without Backer	11.13 - 12.94kN																						
	I-Joist With Backer	13.09 - 21.02kN																						
UH	Open Web / Top Tabs Removed	7.43kN																						
	Open Web	13.23 - 14.19kN																						
	Open Web With Plywood Gusset	16.84 - 22.16kN																						
	Glulam (Min GL28)	16.84 - 22.16kN																						
	LVL	15.25 - 22.17kN																						

## HUH - QUICK REFERENCE GUIDE

Hanger	Header	SWL (kN)													
		1	2	3	4	5	6	7	8	9	10	11	12	13	14
	I-Joist Without Backer	7.80 - 8.10kN													
	I-Joist With Backer	12.13 - 12.30kN													
HUH	Open Web	7.56kN													
	Open Web With Blocking	10.69kN													
	Open Web With Plywood Gusset	12.60kN													
	Glulam (Min GL28)	12.60kN													
	LVL	13.50kN													

Hanger	Header	Characteristic Capacity (kN)																													
		1	2	3	4	5	6	7	8	9	10	11	12	13	14	15	16	17	18	19	20	21	22	23	24	25	26	27	28	29	30
	I-Joist Without Backer	15.50 - 18.50kN																													
	I-Joist With Backer	28.50kN																													
HUH	Open Web	13.95 - 18.60kN																													
	Open Web With Blocking	24.00kN																													
	Open Web With Plywood Gusset	29.50kN																													
	Glulam (Min GL28)	29.50kN																													
	LVL	29.50kN																													

PLEASE REFER TO PRODUCT PAGES FOR EXACT LOAD CAPACITIES



# UH (I-Joist Applications)



## Universal Hanger

Patent Pending

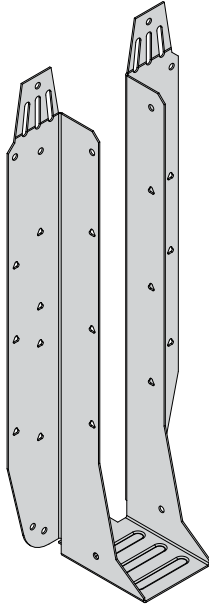

The UH hanger is designed for any joist to joist, joist to trimmer or joist to steel application.

### Features & Benefits

- Elongated slots and unique snap off feature allows for height adjustment and face fix only option
- One hanger solution for backer and backerless I-Joists
- Rear location tab to assist with installation
- Additional triangular fixing holes for increased performance on solid members
- Suitable for connections to steel work - see pages 78 - 79

### Material Specification

- Galvanised mild steel - Z275

### Fixings

Code	Description	Box Qty
547389	3.4 x 35mm Square Twist Nails - LOOSE	500
141185	3.4 x 35mm Square Twist Nails - COLLATED*	2,500

\*For use with Paslode PPN35Ci

(or 3.5 x 30mm wood screw for sacrificial stairwell installation only)

### Available Sizes

Hanger Width (W) (mm)	Hanger Depth (mm)				>300
	195	220	235	300	
39	UH-39-195	UH-39-220	UH-39-235	UH-39-300	SEE HUH (PAGES 67 - 70)
46	UH-46-195	UH-46-220	UH-46-235	UH-46-300	
50	UH-50-195	UH-50-220	UH-50-235	UH-50-300	OR
55	-	-	UH-55-235	UH-55-300	
61	UH-61-195	UH-61-220	UH-61-235	UH-61-300	UH-MHE/ UZ-CLIP (PAGES 54 - 56)
65	UH-65-195	UH-65-220	UH-65-235	UH-65-300	
72	UH-72-195	UH-72-220	UH-72-235	UH-72-300	OR
75	UH-75-195	UH-75-220	UH-75-235	UH-75-300	
78	UH-78-195	UH-78-220	UH-78-235	UH-78-300	FFI (PAGES 63 - 66)
92	UH-92-195	UH-92-220	UH-92-235	UH-92-300	
100	UH-100-195	UH-100-220	UH-100-235	UH-100-300	SEE FFI (PAGES 63 - 66) OR HUH (PAGES 67 - 70) OR MHE (PAGES 80 - 81)
>100					

### Dimensions (mm)

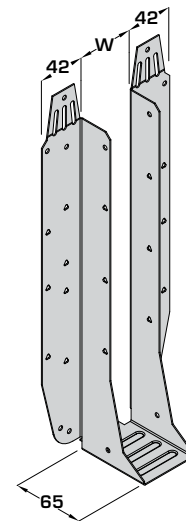

### Height Suitability

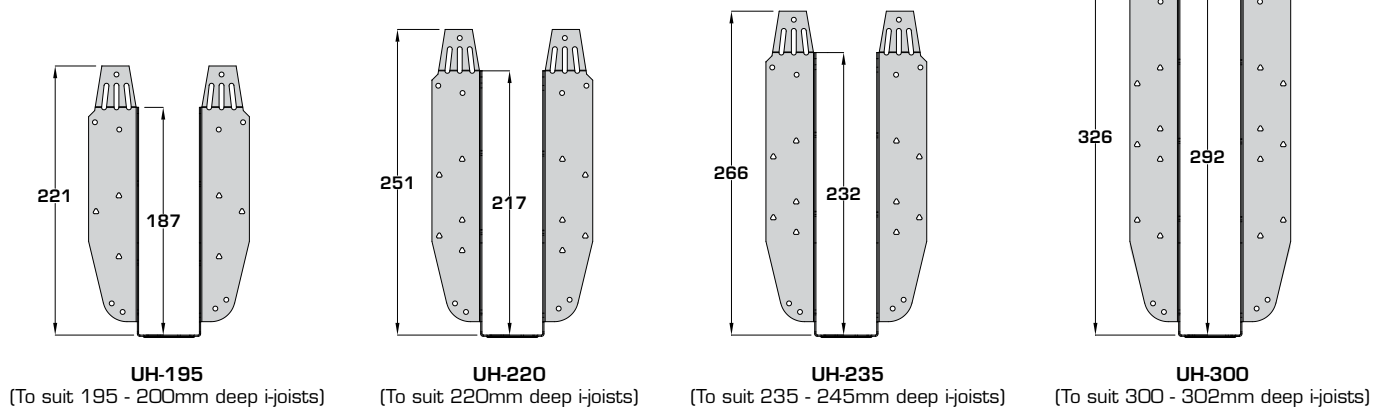

## Universal Hanger

### Standard Installation - I-Joist Header without Backer Block

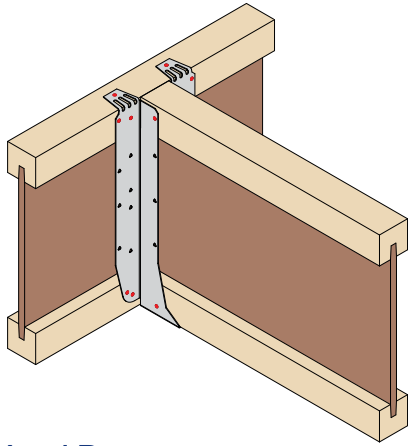

#### See Page 53 For Installation Instructions

- Fill all red holes as indicated for this installation
- No backer block required
- No web stiffeners required\*
- Top tabs to be wiped over and nailed
- Additional triangular holes into face only required for solid headers

\*Additional triangular holes into incoming joist only required for enhanced uplift. (for details see page 51)

#### Load Data

Hanger Depth (mm) (Depth Dependent Only)	Fixings (3.4 x 35mm)			Safe Working Loads (kN)				Characteristic Capacity (kN)		
	Header		Incoming	Uplift - Short Term	Uplift - Long Term	I-Joist Header		Uplift	I-Joist Header	
	Face	Top				Long Term			Solid Flange	LVL Flange
195	8	2	2	1.05	0.87	4.83	4.83	1.98	11.13	12.94
220	8	2	4	2.10	1.75	4.83	4.83	3.97	11.13	12.94
235	8	2	4	2.10	1.75	4.50	4.63	3.97	11.89	11.79
300	8	2	4	2.10	1.75	4.50	4.63	3.97	11.89	11.79

### Enhanced Installation - I-Joist Header with Backer Block

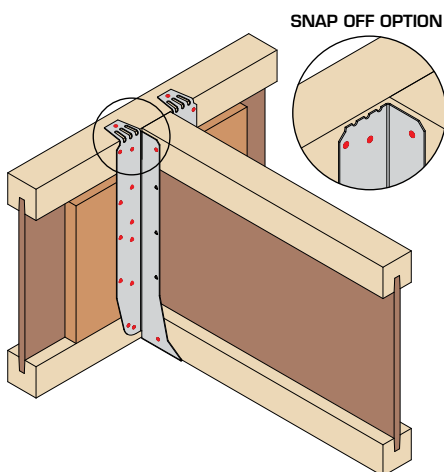

#### See Page 53 For Installation Instructions

- Fill all red holes as indicated for this installation
- All nail holes filled into backer block (including triangular)
- Backer block required to hanger side only (follow i-joist manufacturer's guidelines)
- No web stiffeners required when using same hanger/joist depth\*
- Top tabs to be wiped over and nailed or snapped off to give face fix only option

\*Additional triangular holes into incoming joist only required for enhanced uplift. (for details see page 51)

#### Load Data

Hanger Depth (mm) (Depth Dependent Only)	Fixings (3.4 x 35mm)			Safe Working Loads (kN)				Characteristic Capacity (kN)		
	Header		Incoming	Uplift - Short Term	Uplift - Long Term	I-Joist Header with Backer Block		Uplift	I-Joist Header with Backer Block	
	Face	Top				Long Term			Solid Flange	LVL Flange
195	14	2 (0**)	2	1.05	0.87	7.13	7.59	1.98	13.09	13.49
220	18	2 (0**)	4	2.10	1.75	7.46	7.59	3.97	19.66	18.81
235	18	2 (0**)	4	2.10	1.75	9.49	9.64	3.97	19.66	18.81
300	22	2 (0**)	4	2.10	1.75	9.97	10.23	3.97	21.02	20.88

\*\*No fixings required when using snap off option.

## Universal Hanger

### Enhanced Installation - Solid Header

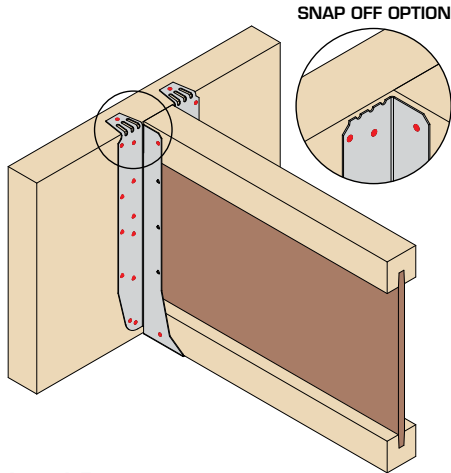

- Fill all red holes as indicated for this installation
- All nail holes filled into solid header (including triangular)
- No web stiffeners required when using same hanger/joist depth\*
- Top tabs to be wiped over and nailed or snapped off to give face fix only option

\*Additional triangular holes into incoming joist only required for enhanced uplift. (for details see below)

#### Load Data

Hanger Depth (mm) (Depth Dependent Only)	Fixings (3.4 x 35mm)			Safe Working Loads (kN)				Characteristic Capacity (kN)		
	Header		Incoming	Uplift - Short Term	Uplift - Long Term	Solid Header		Uplift	Solid Header	
	Face	Top				Long Term			GL (Min GL28)	LVL
						GL (Min GL28)	LVL			
195	14	2 (0**)	2	1.05	0.87	7.13	10.24	1.98	16.84	15.25
220	18	2 (0**)	4	2.10	1.75	7.13	10.24	3.97	19.69	18.65
235	18	2 (0**)	4	2.10	1.75	7.46	11.97	3.97	22.16	21.58
300	22	2 (0**)	4	2.10	1.75	8.12	11.97	3.97	22.16	22.17

\*\*No fixings required when using snap off option.

### Enhanced Uplift

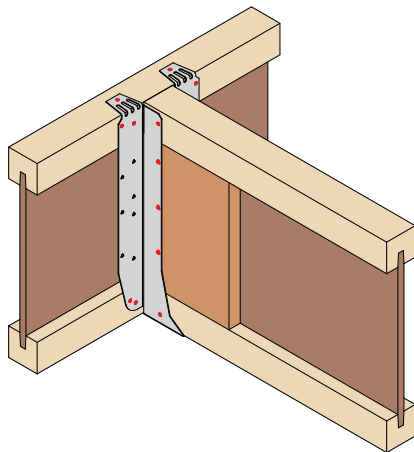

- Fill all red holes as indicated for this installation
- Fixings into the incoming joist are required to resist uplift
- Increased uplift figures can be achieved by nailing the additional triangular nail holes into the incoming member - solid incoming or web stiffeners are required

#### Load Data

Hanger Depth (mm) (Depth Dependent Only)	Fixings (3.4 x 35mm)	Safe Working Loads (kN)		Characteristic Capacity (kN)
	Incoming	Uplift - Short Term	Uplift - Long Term	Uplift
195	6	2.98	2.48	5.97
220 - 300	8	3.98	3.31	7.97

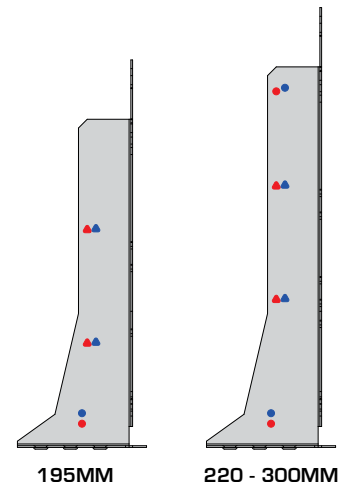

● Near side  
● Far side

## Universal Hanger

### Sacrificial Stairwell Installation

Face Fix Option

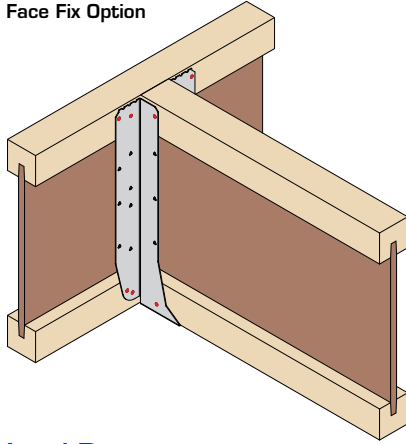

Top Fix Option

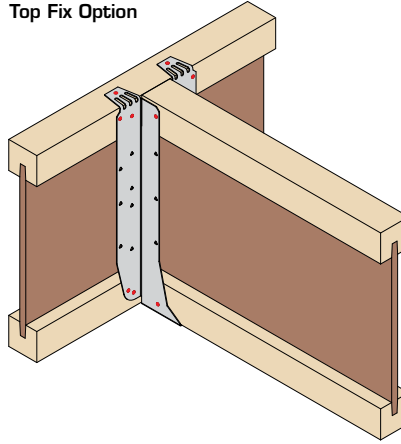

- Fill all red holes as indicated for these installations
- No backer blocks required
- No web stiffeners required

### Load Data

Hanger Depth (mm) (Depth Dependent Only)	Fixings (3.4 x 35mm)			Safe Working Loads (kN)				Characteristic Capacity (kN)		
	Header		Incoming	Uplift - Short Term	Uplift - Long Term	I-Joist Header		Uplift	I-Joist Header	
	Face	Top				Solid Flange	LVL Flange		Solid Flange	LVL Flange
195	8	2 (0**)	2	1.05	0.87	3.5	3.50	1.98	7.43	7.83
220	8	2 (0**)	4	2.10	1.75	3.5	3.50	3.97	7.43	7.83
235	8	2 (0**)	4	2.10	1.75	3.0	3.0	3.97	7.43	7.83
300	8	2 (0**)	4	2.10	1.75	3.0	3.0	3.97	7.43	7.83

\*\*No fixings required when using snap off option.

3.5 x 30mm multi-purpose wood screws may be used as an alternative fixing for temporary supporting hanger.

### Installation Instructions

Face Fix Option

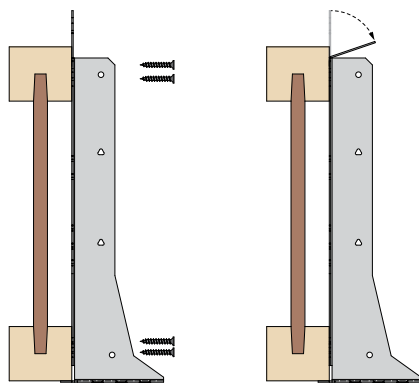

Face fix to top and bottom flanges using 8No 3.5 x 30mm multi purpose wood screws or 3.4 x 35mm square twist nails.

Bend tabs forward and snap off.

Once ready for stairs to be installed the deck can be cut and joists/hangers removed.

Top Fix Option

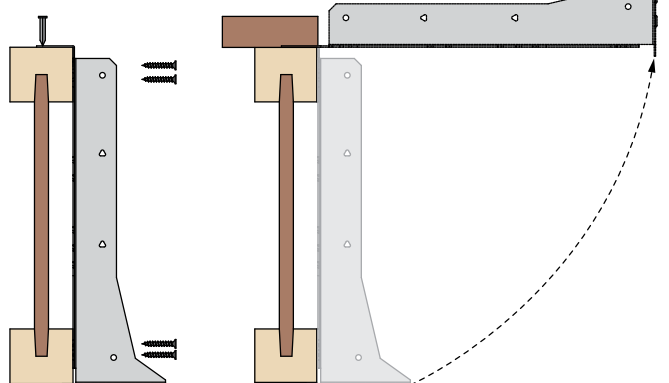

Face fix to top and bottom flanges using 8No 3.5 x 30mm multi purpose wood screws or 3.4 x 35mm square twist nails.

Bend top tabs over joist top flange and nail using 1No 3.4 x 35mm square twist nail per leg.

Once ready for stairs to be installed the deck can be cut and joists/hangers removed.

Hanger to be rotated through 90 degrees to snap off at break line.

## Universal Hanger

### Standard Installation Instructions - I-Joist Header without Backer Block

STAGE 1

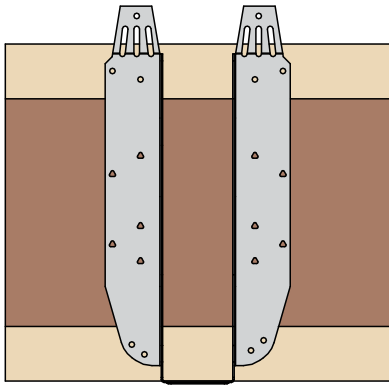

Position hanger against face of I-Joist with locating tab tight to underside of joist.

STAGE 2

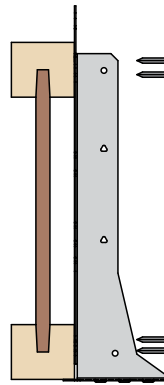

Face nail to top and bottom flanges using 8No 3.4 x 35mm square twist nails in total.

STAGE 3

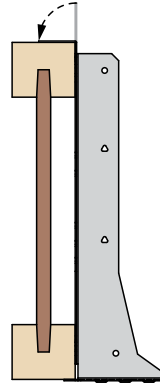

Wipe over top tabs to give a flush fit to the joist.

STAGE 4

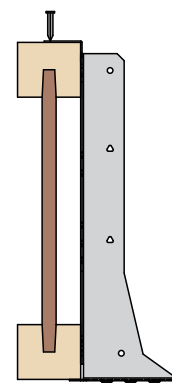

Nail top tabs into top flange of joist - 1No 3.4 x 35mm square twist nail per tab.

### Enhanced Installation Instructions - I-Joist Header with Backer Block

STAGE 1

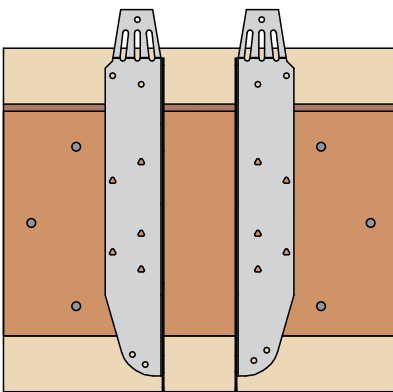

Position hanger against face of I-Joist with locating tab tight to underside of joist.

Backer block installed as per I-Joist manufacturer's guidelines.

STAGE 2

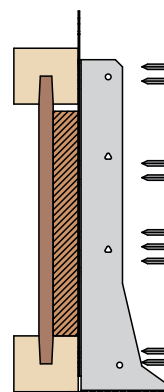

Fill all round and triangular nail holes to header and backer face with 3.4 x 35mm square twist nails.

STAGE 3

Option 1

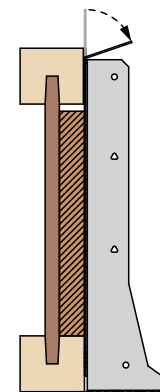

Bend top tab forward and snap off.

Option 2

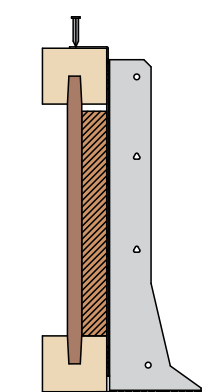

Wipe over top tabs to give a flush fit to the joist.

Nail top tabs into top flange of joist - 1No 3.4 x 35mm square twist nail per tab.

## Universal Hanger

### UH/MHE With UZ-Clip Installation (to support 350 - 450mm deep I-Joists)

UH-300 & UZ Clip - For Single Joists

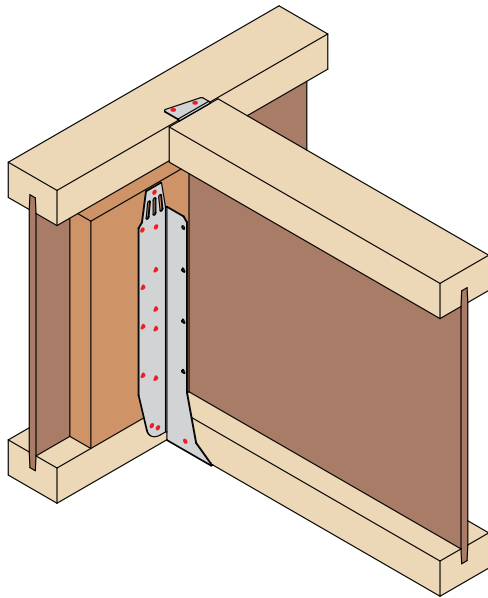

MHE & UZ Clip - For Double Joists

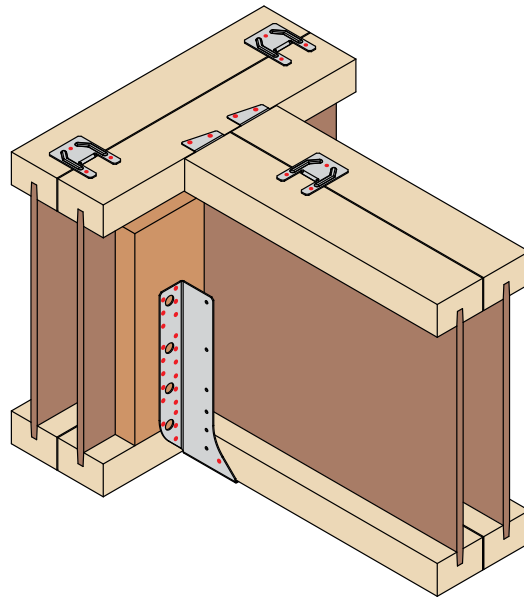

#### Features & Benefits

- Solution to support 350 - 450mm deep I-Joists with shallower UH/MHE hanger and UZ-Clip to prevent rotation and remove the need for installing time consuming web stiffeners
- Shallower height UH (300mm) and MHE (620) hangers can be used to replace deeper FFI 350, 400 and 450mm deep hangers

#### Available Sizes

Joist Depth (mm)	Hanger Width (mm)									
	39	46	50	61	65	72	75	78	92	100
350	UH-39-300	UH-46-300	UH-50-300	UH-61-300	UH-65-300	UH-72-300	UH-75-300	UH-78-300	UH-92-300	UH-100-300
400	UH-39-300	UH-46-300	UH-50-300	UH-61-300	UH-65-300	UH-72-300	UH-75-300	UH-78-300	UH-92-300	UH-100-300
450	UH-39-300	UH-46-300	UH-50-300	UH-61-300	UH-65-300	UH-72-300	UH-75-300	UH-78-300	UH-92-300	UH-100-300

Joist Depth (mm)	Hanger Width (mm)						
	122	130	138	144	150	183	198
350	MHE620-122-249	MHE620-130-245	MHE620-138-241	MHE620-144-238	MHE620-150-235	MHE620-183-218	MHE620-198-211
400	MHE620-122-249	MHE620-130-245	MHE620-138-241	MHE620-144-238	MHE620-150-235	MHE620-183-218	MHE620-198-211
450	MHE620-122-249	MHE620-130-245	MHE620-138-241	MHE620-144-238	MHE620-150-235	MHE620-183-218	MHE620-198-211

Flange Depth (mm)	UZ-Clip
36	UZ-35
39	UZ-38
45	UZ-45
47	UZ-47

UZ-Clip size dependent on flange size only and not I-Joist width - 1No UZ-Clip required per I-Joist (38 - 97mm wide)

## Universal Hanger

### UH (300) & UZ-Clip - I-Joist Header with Backer Block or Solid Header

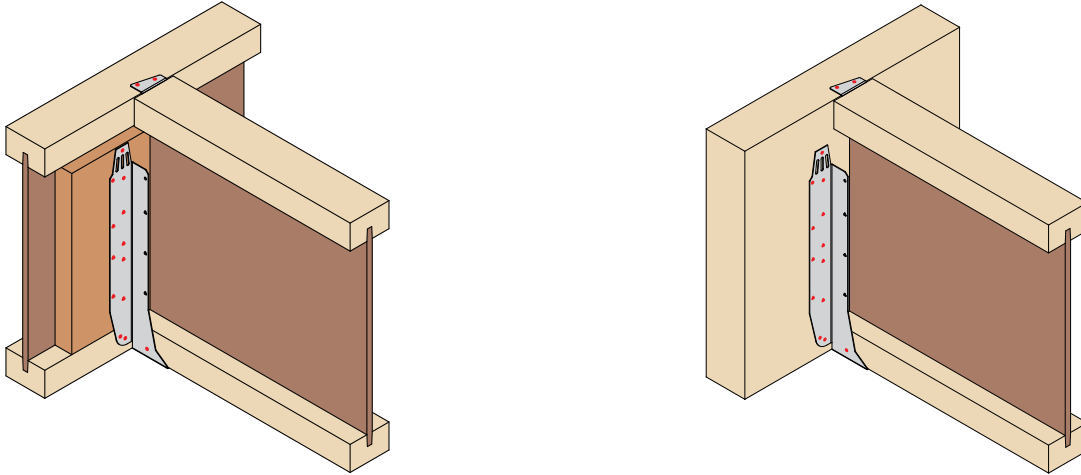

#### Load Data

Hanger Width (mm)	Fixings (3.4 x 35mm)			Safe Working Loads (kN)			Characteristic Capacity (kN)	
	Header		Incoming	Uplift - Short Term	Uplift - Long Term	Header	Uplift	Header
	Face	Top				Long Term		Solid Flange I-Joist, LVL Flange I-Joist, GL & LVL
39 - 65	24	0	2	1.05	0.87	4.72	2.00	12.49
72 - 100	24	0	2	1.05	0.87	6.43	2.00	16.90

### MHE (620) & UZ-Clip - I-Joist Header with Backer Block or Solid Header

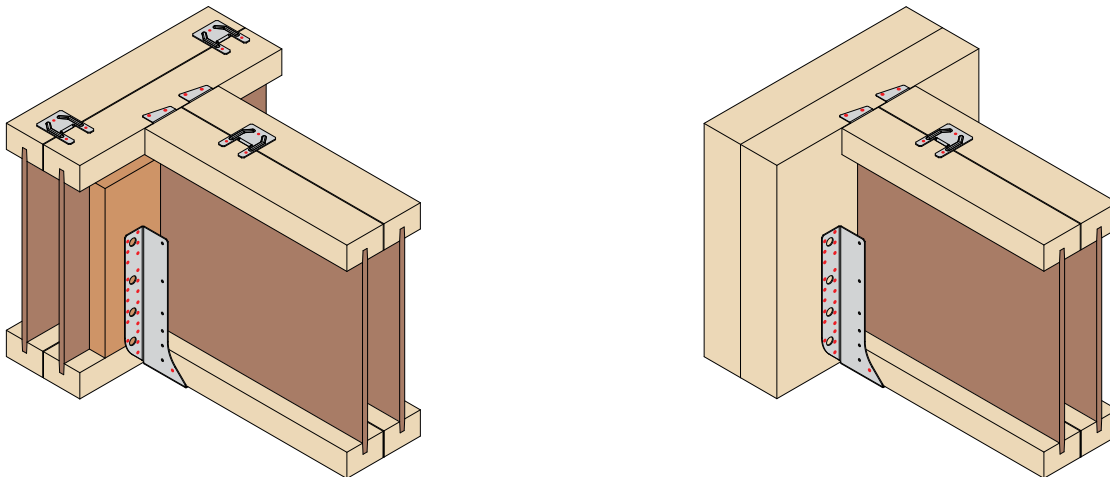

#### Load Data

Hanger Width (mm)	Fixings (3.4 x 35mm)			Safe Working Loads (kN)			Characteristic Capacity (kN)	
	Header		Incoming	Uplift - Short Term	Uplift - Long Term	Header	Uplift	Header
	Face	Top				Long Term		Solid Flange I-Joist, LVL Flange I-Joist, GL & LVL
122 - 198	24	0	2	1.05	0.87	14.83	2.00	30.58

## Universal Hanger

### UH-300 & UZ-Clip - Installation

STAGE 1

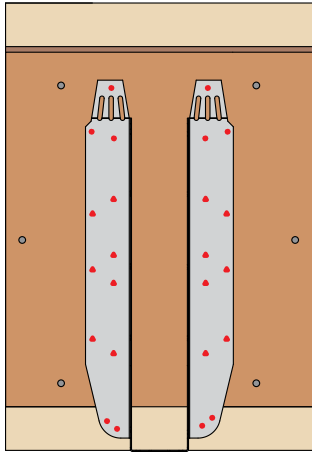

Position hanger against face of I-Joist with locating tab tight to underside of joist.

Backer block installed as per I-Joist manufacturer's guidelines.

STAGE 2

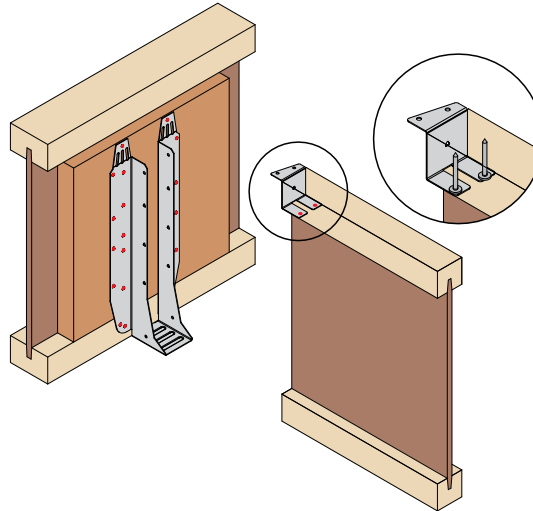

Fix UZ-Clip to top flange of supported member using:

2No 3.4 x 35mm square twist nails.

2No UZ-Clips required for double incoming.

STAGE 3

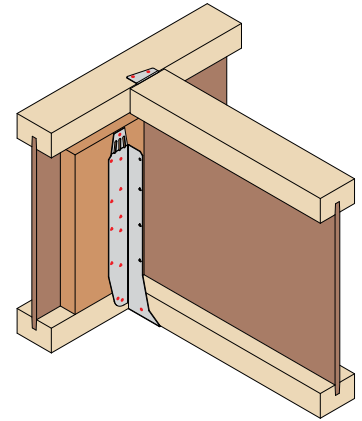

Offer incoming member into the UH hanger and fix to joist bottom flange/backer block and UZ-Clip to header member.

### MHE & UZ-Clip - Installation

STAGE 1

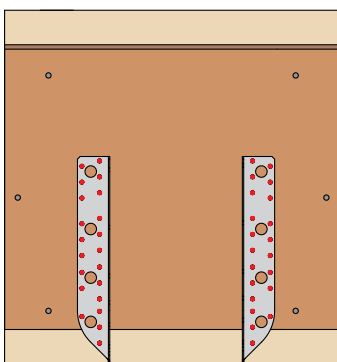

Position hanger against face of I-Joist with locating tab tight to underside of joist.

Backer block installed as per I-Joist manufacturer's guidelines.

STAGE 2

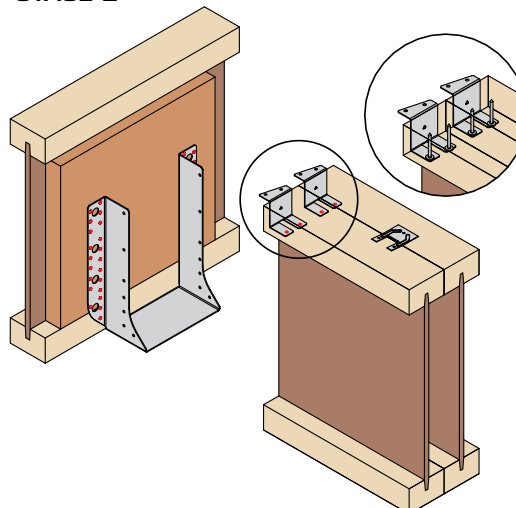

Fix UZ-Clips to top flange of supported member using:

2No 3.4 x 35mm square twist nails per UZ-Clip.

2No UZ-Clips required for double incoming.

STAGE 3

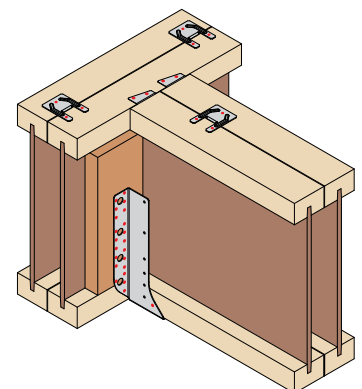

Offer incoming member into the MHE hanger and fix to joist bottom flange/backer block and UZ-Clips to header member.



# UH (Open Web Applications)



## Universal Hanger

Patent Pending

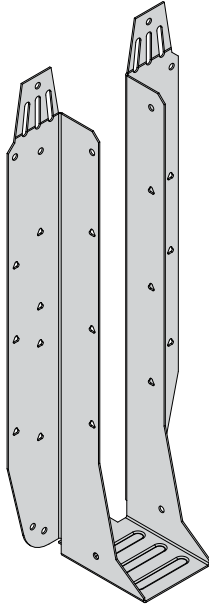

The UH hanger is designed for any joist to joist, joist to trimmer or joist to steel application.

### Features & Benefits

- Elongated slots and unique snap off feature allows for height adjustment and face fix only option
- One hanger solution for backer and backerless I-Joists
- Rear location tab to assist with installation
- Additional triangular fixing holes for increased performance on solid members
- Suitable for connections to steel work - see pages 78 - 79

### Material Specification

- Galvanised mild steel - Z275

### Fixings

Code	Description	Box Qty
547389	3.4 x 35mm Square Twist Nails - LOOSE	500
141185	3.4 x 35mm Square Twist Nails - COLLATED*	2,500

\*For use with Paslode PPN35Ci

(or 3.5 x 30mm wood screw for sacrificial stairwell installation only)

### Available Sizes

Hanger Width (W) (mm)	Hanger Depth (mm)				
	195	220	235	300	>300
39	UH-39-195	UH-39-220	UH-39-235	UH-39-300	
46	UH-46-195	UH-46-220	UH-46-235	UH-46-300	
50	UH-50-195	UH-50-220	UH-50-235	UH-50-300	
75	UH-75-195	UH-75-220	UH-75-235	UH-75-300	SEE HUH (PAGES 71 - 72)
78	UH-78-195	UH-78-220	UH-78-235	UH-78-300	
92	UH-92-195	UH-92-220	UH-92-235	UH-92-300	
100	UH-100-195	UH-100-220	UH-100-235	UH-100-300	
>100	SEE HUH (PAGES 71 - 72) OR MHE (PAGES 80 - 81)				

### Dimensions (mm)

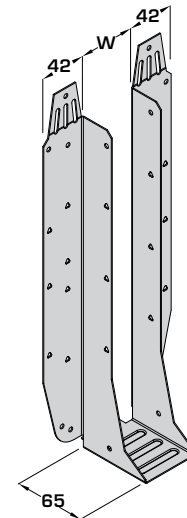

### Height Suitability

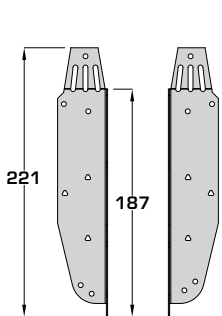

**UH-195**  
(To suit 195 - 202mm deep open web joists)

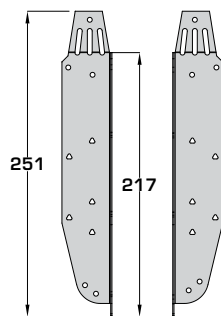

**UH-220**  
(To suit 219 & 225mm deep open web joists)

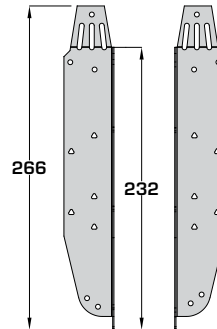

**UH-235**  
(To suit 253 - 254mm deep open web joists)

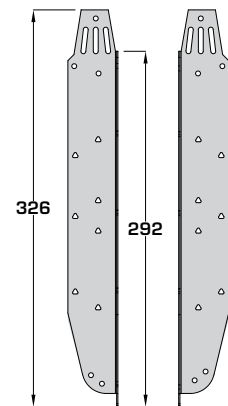

**UH-300**  
(To suit 304mm deep open web joists)

## Universal Hanger

### Standard Installation - Open Web Header

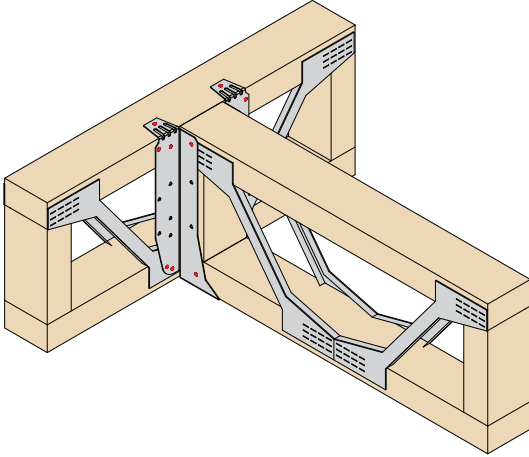

#### See Page 61 For Installation Instructions

- Fill all red holes as indicated for this installation
- No backer block/plywood gusset required
- Top tabs to be wiped over and nailed
- Additional triangular holes into face only required for solid headers

Additional triangular holes into incoming joist only required for enhanced uplift. (for details see page 59)

#### Load Data

Hanger Depth (mm) (Depth Dependent Only)	Fixings (3.4 x 35mm)			Safe Working Loads (kN)			Characteristic Capacity (kN)	
	Header		Incoming	Uplift - Short Term	Uplift - Long Term	Open Web Header Long Term	Uplift	Open Web Header
	Face	Top						
195	8	2	2	1.05	0.87	5.80	1.98	14.19
220	8	2	4	2.10	1.75	5.80	3.97	14.19
235	8	2	4	2.10	1.75	5.80	3.97	13.23
300	8	2	4	2.10	1.75	5.80	3.97	13.64

### Enhanced Installation - Solid Header

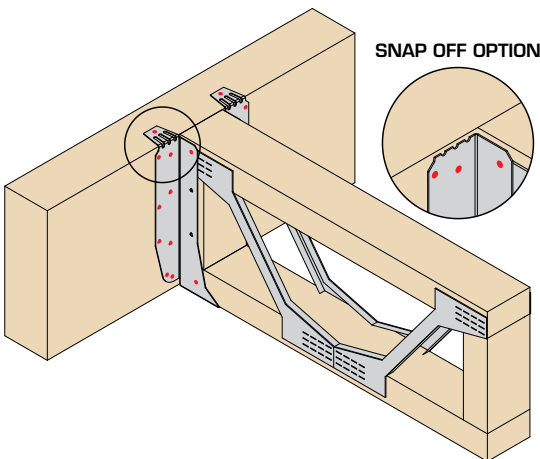

#### See Page 61 For Installation Instructions

- Fill all red holes as indicated for this installation
- All nail holes filled into solid header (including triangular)
- Top tabs to be wiped over and nailed or snapped off to give face fix only option

Additional triangular holes into incoming joist only required for enhanced uplift. (for details see page 59)

#### Load Data

Hanger Depth (mm) (Depth Dependent Only)	Fixings (3.4 x 35mm)			Safe Working Loads (kN)				Characteristic Capacity (kN)		
	Header		Incoming	Uplift - Short Term	Uplift - Long Term	Solid Header Long Term		Uplift	GL (Min GL28)	LVL
	Face	Top				GL (Min GL28)	LVL			
195	14	2 (0**)	2	1.05	0.87	7.13	10.24	1.98	16.84	15.25
220	18	2 (0**)	4	2.10	1.75	7.13	10.24	3.97	19.69	18.65
235	18	2 (0**)	4	2.10	1.75	7.46	11.97	3.97	22.16	21.58
300	22	2 (0**)	4	2.10	1.75	8.12	11.97	3.97	22.16	22.17

\*\*No fixings required when using snap off option

## Universal Hanger

### Enhanced Installation - Open Web Header with Plywood Gusset

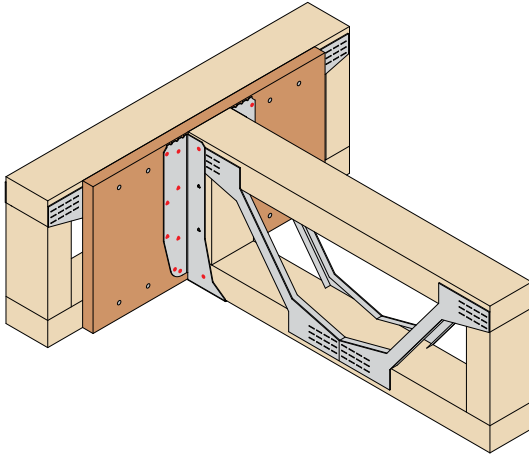

#### See Page 62 For Installation Instructions

- Fill all red holes as indicated for this installation
- 18mm plywood gusset should be screwed into open web header with the appropriate screws - see installation instructions for more information
- All nail holes filled into plywood gusset (including triangular)
- Top tabs snapped off to give face fix only fixing

Additional triangular holes into incoming joist only required for enhanced uplift. (for details see below)

#### Load Data

Hanger Depth (mm) (Depth Dependent Only)	Fixings (3.4 x 35mm)			Safe Working Loads (kN)			Characteristic Capacity (kN)	
	Header		Incoming	Uplift - Short Term	Uplift - Long Term	Open Web Header / 18mm Plywood Gusset Long Term	Uplift	Open Web Header / 18mm Plywood Gusset
	Face	Top						
195	14	0	2	1.05	0.87	7.13	1.98	16.84
220	18	0	4	2.10	1.75	7.13	3.97	19.69
235	18	0	4	2.10	1.75	7.46	3.97	22.16
300	22	0	4	2.10	1.75	8.12	3.97	22.16

### Enhanced Uplift

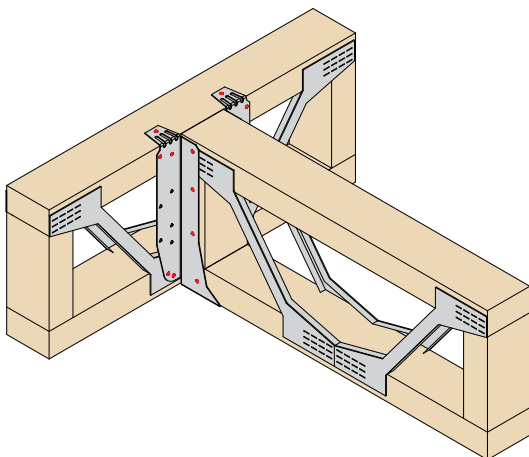

- Fill all red holes as indicated for this installation
- Fixings into the incoming joist are required to resist uplift
- Increased uplift figures can be achieved by nailing the additional triangular nail holes into the incoming member - solid incoming or web stiffeners are required

#### Load Data

Hanger Depth (mm) (Depth Dependent Only)	Fixings (3.4 x 35mm)	Safe Working Loads (kN)		Characteristic Capacity (kN)
	Incoming	Uplift - Short Term	Uplift - Long Term	Uplift
195	6	2.98	2.48	5.97
220 - 300	8	3.98	3.31	7.97

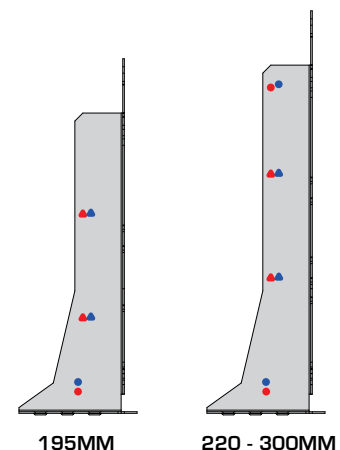

- Near side
- Far side

## Universal Hanger

### Sacrificial Stairwell Installation

Face Fix Option

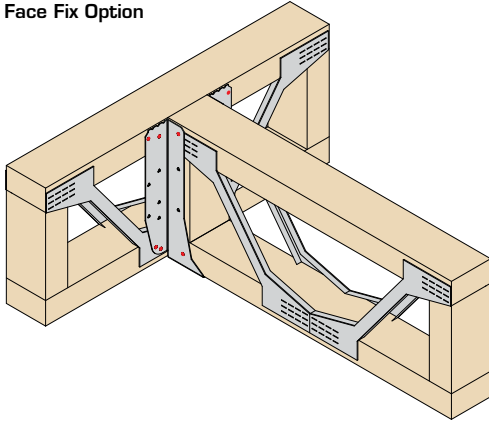

Top Fix Option

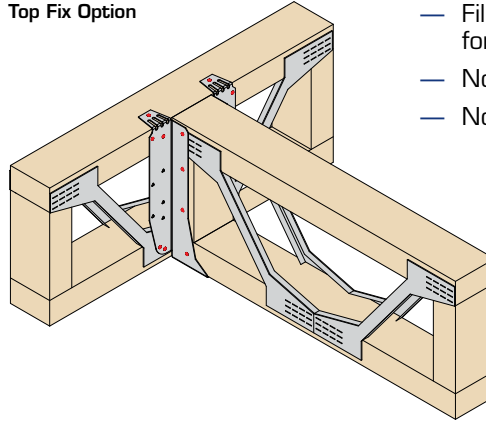

- Fill all red holes as indicated for this installation
- No web stiffeners required
- No backer blocks required

### Load Data

Hanger Depth (mm) (Depth Dependent Only)	Fixings (3.4 x 35mm)			Safe Working Loads (kN)			Characteristic Capacity (kN)	
	Header		Incoming	Uplift - Short Term	Uplift - Long Term	Open Web Header Long Term	Uplift	Open Web Header
	Face	Top						
195	8	2 (0**)	2	1.05	1.75	3.50	1.98	7.43
220	8	2 (0**)	4	2.10	1.75	3.50	3.97	7.43
235	8	2 (0**)	4	2.10	1.75	3.00	3.97	7.43
300	8	2 (0**)	4	2.10	1.75	3.00	3.97	7.43

\*\*No fixings required when using snap off option

3.5 x 30mm multi-purpose wood screws may be used as an alternative fixing for temporary supporting hanger.

### Installation Instructions

Face Fix Option

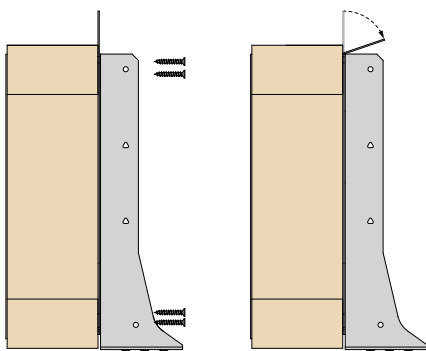

Face fix to top and bottom chords using 8No screws or nails.

Bend tabs forward and snap off.

Once ready for stairs to be installed the deck can be cut and joists/hangers removed.

Top Fix Option

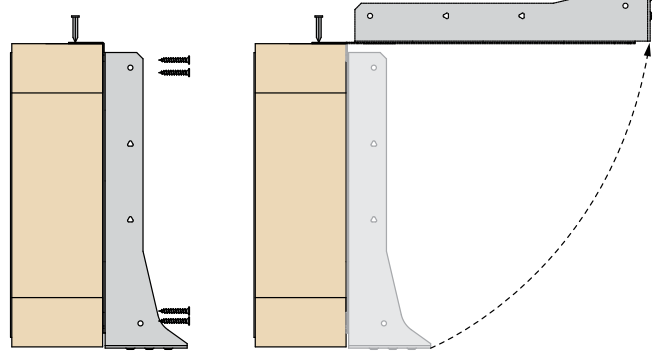

Face fix to top and bottom chords using 8No screws or nails.

Bend top tabs over joist top flange and nail using 1No fixing per leg.

Once ready for stairs to be installed the deck can be cut and joists/hangers removed.

Hanger to be rotated through 90° to snap off at break line.

## Universal Hanger

### Standard Installation Instructions - Open Web Header

STAGE 1

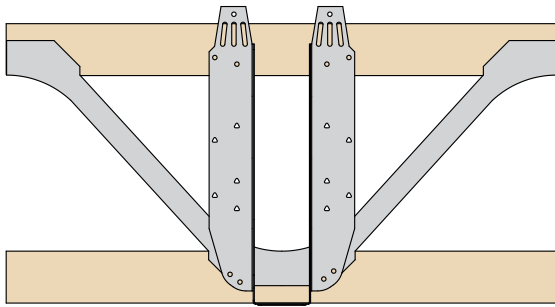

Position hanger against face of open web joist with locating tab tight to underside of joist.

STAGE 2

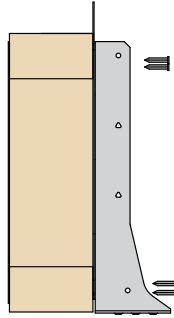

Face nail to top and bottom chords using 8No 3.4 x 35mm square twist nails in total.

STAGE 3

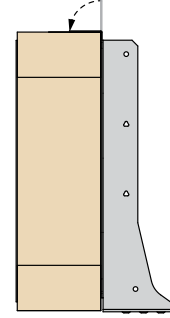

Wipe over top tabs to give a flush fit to the joist.

STAGE 4

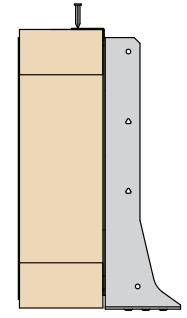

Nail top tabs into top chord of joist - 1No 3.4 x 35mm square twist nail per tab.

### Enhanced Installation Instructions - Solid Header

STAGE 1

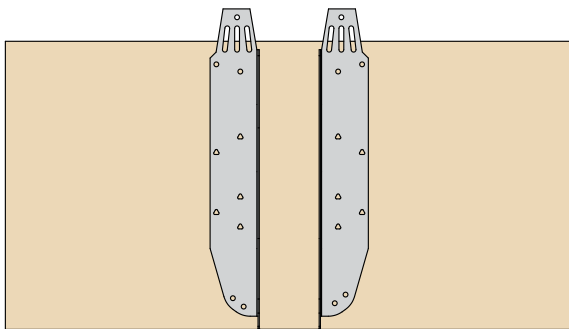

Position hanger against face of joist with locating tab tight to underside of joist.

STAGE 2

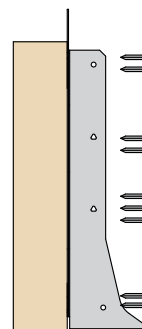

Fill all round and triangular nail holes to header with 3.4 x 35mm square twist nails.

STAGE 3

Option 1

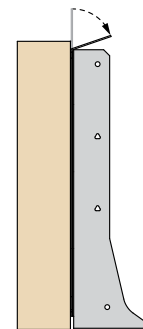

Bend top tab forward and snap off.

Option 2

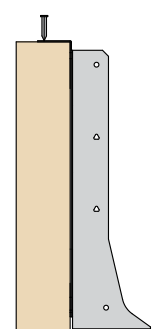

Wipe over top tabs to give a flush fit to the joist.

Nail top tabs into top chord of joist - 1No 3.4 x 35mm square twist nail per tab.

## Universal Hanger

### Open Web Header With Plywood Gusset Instructions

#### STAGE 1

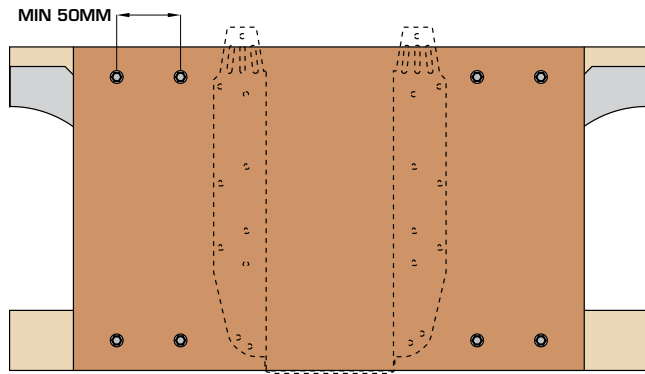

18mm plywood should be fixed to the face of the open web joist with 4No PSTS 6.5mm into the top chord and 4No PSTS 6.5mm into the bottom chord.

Plywood should be the full depth of the open web and of a width to give the screws the appropriate edge distance.

Paslode Structural Timber Screws should be used to fix the plywood to the open web joist. The screw length is dependant on the joist thickness.

#### STAGE 2

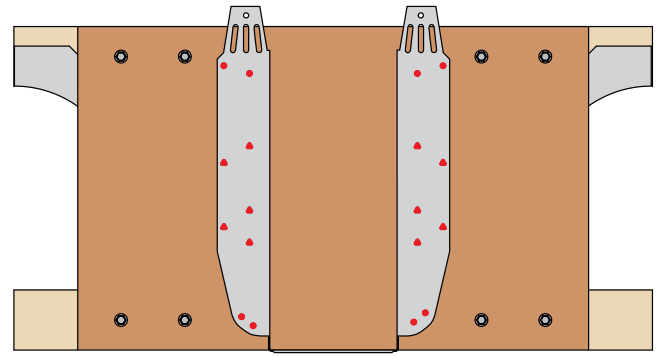

Position hanger flush with underside of joist.

Circular nail holes filled from bottom to top ensuring hanger side flanges are plumb.

All fixings are 3.4 x 35mm square twist nails.

Optional triangular nail holes should also be filled.

#### STAGE 3

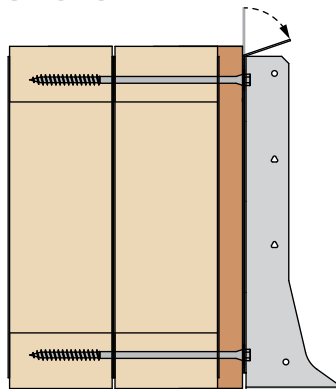

Bend top tabs forward and snap off.

#### Screw Specification

Header Joist Thickness	Fixing Ref	Product Code	Box Qty
Single 72mm	PSTS6.5X65	551105	100
Single 97mm	PSTS6.5X100	551106	100
Single 122mm	PSTS6.5X100	551106	100
Single 147mm	PSTS6.5X115	551102	100
Double 72mm	PSTS6.5X150	551107	100
Double 97mm	PSTS6.5X200	551108	100
Double 122mm	PSTS6.5X200	551108	100
Double 147mm	PSTS6.5X250	551109	100

## Face Fix I-Joist Hanger



The FFI hanger is designed for any joist to joist, joist to trimmer or joist to steel application.

### Features & Benefits

- Rear location tab to assist with installation
- Face fix only option (backer blocks required)
- No need for web stiffeners (unless required from I-Joist provider)
- Suitable for connections to steel work

### Material Specification

- Galvanised mild steel - Z275

### Fixings

Code	Description	Box Qty
547389	3.4 x 35mm Square Twist Nails - LOOSE	500
141185	3.4 x 35mm Square Twist Nails - COLLATED*	2,500

\*For use with Paslode PPN35C

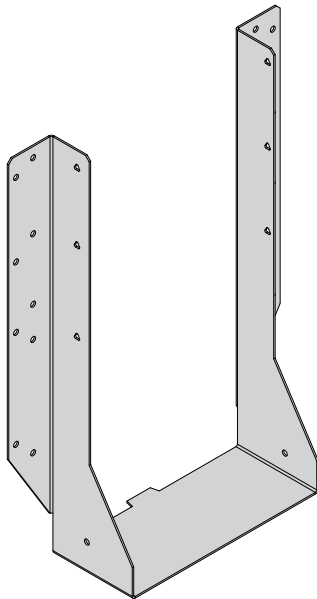

### Available Sizes

Hanger Width (W) (mm)	Hanger Depth (mm)					
	195	220	235	300	350	400
39					FFI-39-350	FFI-39-400
46					FFI-46-350	FFI-46-400
50					FFI-50-350	FFI-50-400
61					FFI-61-350	FFI-61-400
65					FFI-65-350	FFI-65-400
72	SEE UH (PAGES 49 - 52)					
75					FFI-75-350	FFI-75-400
78					FFI-78-350	FFI-78-400
92					FFI-92-350	FFI-92-400
100					FFI-100-350	FFI-100-400
122	FFI-122-195	FFI-122-220	FFI-122-235	FFI-122-300	FFI-122-350	FFI-122-400
130	FFI-130-195	FFI-130-220	FFI-130-235	FFI-130-300	FFI-130-350	FFI-130-400
138	FFI-138-195	FFI-138-220	FFI-138-235	FFI-138-300	FFI-138-350	FFI-138-400
144	FFI-144-195	FFI-144-220	FFI-144-235	FFI-144-300	FFI-144-350	FFI-144-400
150	FFI-150-195	FFI-150-220	FFI-150-235	FFI-150-300	FFI-150-350	FFI-150-400
183	FFI-183-195	FFI-183-220	FFI-183-235	FFI-183-300	FFI-183-350	FFI-183-400
198	FFI-198-195	FFI-198-220	FFI-198-235	FFI-198-300	FFI-198-350	FFI-198-400
>198	SEE HUH (PAGES 67 - 70)					

### Dimensions (mm)

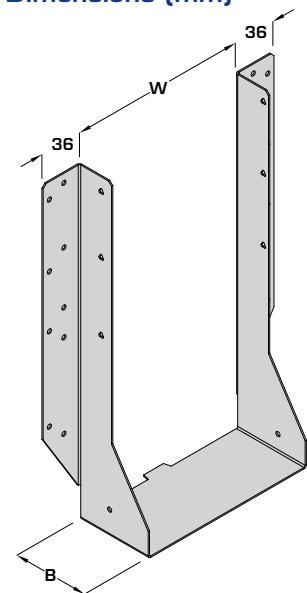

195 - 300mm deep B = 65mm  
350 - 400mm deep B = 92mm

### Height Suitability

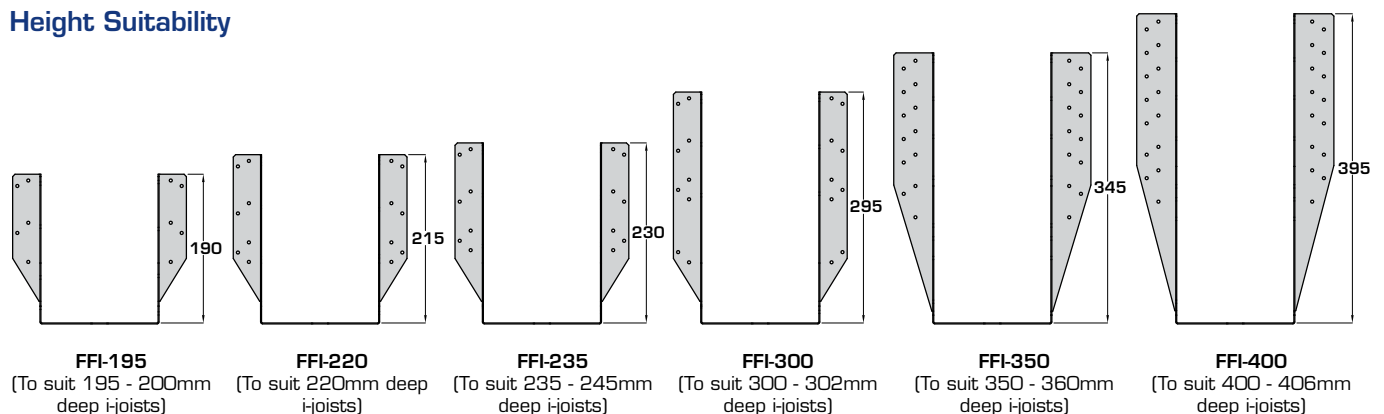

## Face Fix I-Joist Hanger

### I-Joist Incoming - I-Joist Header With Backer Block

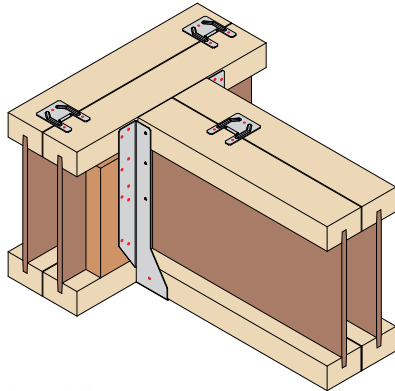

#### See Page 66 For Installation Instructions

- Fill all red holes as indicated for this installation
- Backer block required to hanger side only
- All face fixings required into header member
- Web stiffeners not required (unless required from i-joist provider)

**NEW NHBC  
ACCEPTED DETAIL**

To support  
**350 - 450mm  
deep joists  
(see page 54)**

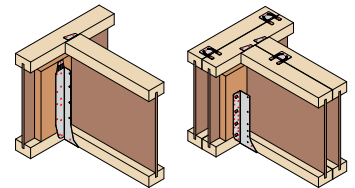

Additional triangular holes into incoming joist only required for enhanced uplift. (for details see page 65)

#### Load Data

Hanger Width (mm)	Hanger Depth (mm)	Fixings (3.4 x 35mm)		Safe Working Loads (kN)				Characteristic Capacity (kN)		
		Header Face	Incoming	Uplift - Short Term	Uplift - Long Term	I-Joist Header with Backer Block Long Term		Uplift	I-Joist Header	
						Solid Flange	LVL Flange		Solid Flange	LVL Flange
39 - 100	350	26	2	1.80	1.50	10.46	9.64	0.89	19.75	18.63
	400	30	2	1.80	1.50	6.36	9.06	0.89	22.00	23.99
	195	10	2	1.80	1.50	7.13	7.59	0.89	10.32	12.16
	220	12	2	1.80	1.50	7.46	7.59	0.89	10.32	12.16
122 - 198	235	14	2	1.80	1.50	9.49	9.64	0.89	15.26	15.26
	300	18	2	1.80	1.50	9.97	10.23	0.89	19.16	20.66
	350	26	2	1.80	1.50	10.46	11.46	0.89	20.12	20.02
	400	30	2	1.80	1.50	10.95	11.46	0.89	22.20	25.21

### I-Joist Incoming - Solid Header

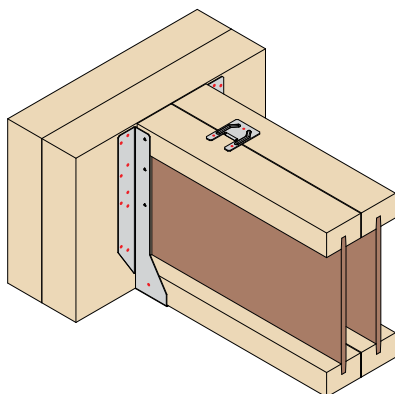

#### See Page 66 For Installation Instructions

- Fill all red holes as indicated for this installation
- All face fixings required into header member
- Web stiffeners not required (unless required from I-Joist provider)

**NEW NHBC  
ACCEPTED DETAIL**

To support  
**350 - 450mm  
deep joists  
(see page 54)**

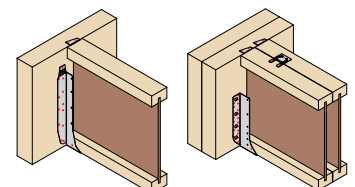

Additional triangular holes into incoming joist only required for enhanced uplift. (for details see page 65)

#### Load Data

Hanger Width (mm)	Hanger Depth (mm)	Fixings (3.4 x 35mm)		Safe Working Loads (kN)				Characteristic Capacity (kN)		
		Header Face	Incoming	Uplift - Short Term	Uplift - Long Term	Solid Header Long Term		Uplift	Solid Header	
						GL (Min GL28)	LVL		GL (Min GL28)	LVL
39 - 100	350	26	2	1.80	1.50	9.44	9.80	0.89	24.58	25.75
	400	30	2	1.80	1.50	10.10	9.80	0.89	24.63	27.07
	195	10	2	1.80	1.50	7.13	8.16	0.89	10.95	13.92
	220	12	2	1.80	1.50	7.13	8.70	0.89	10.95	13.92
122 - 198	235	14	2	1.80	1.50	7.46	9.80	0.89	13.13	15.79
	300	18	2	1.80	1.50	8.12	10.23	0.89	16.94	15.59
	350	26	2	1.80	1.50	9.44	11.46	0.89	24.58	25.75
	400	30	2	1.80	1.50	10.10	12.69	0.89	24.63	27.07



## Face Fix I-Joist Hanger

### Solid Incoming - Solid Header

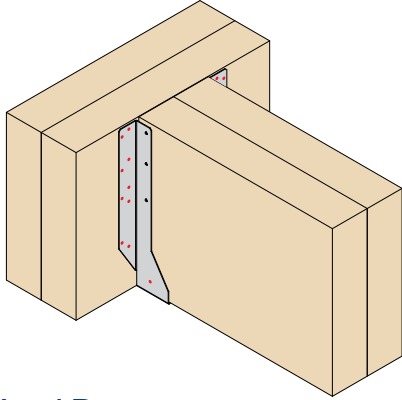

**See Page 66 For Installation Instructions**

- Fill all red holes as indicated for this installation
- All face fixings required into header member

**ALTERNATIVE OPTION - MHE**  
(see pages 112 - 113)

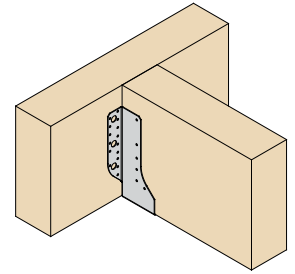

Additional triangular holes into incoming joist only required for enhanced uplift. (for details see below)

#### Load Data

Hanger Width (mm)	Hanger Depth (mm)	Fixings (3.4 x 35mm)		Safe Working Loads (kN)				Characteristic Capacity (kN)	
		Header	Incoming	Uplift - Short Term	Uplift - Long Term	Solid Header		Uplift	Solid Header
						Long Term			
		Face		GL (Min GL28)	LVL		LVL		
39 - 100	350	26	2	1.80	1.50	9.44	18.08	0.89	25.75
	400	30	2	1.80	1.50	10.10	24.50	0.89	27.07
	195	10	2	1.80	1.50	7.13	10.24	0.89	13.92
122 - 198	220	12	2	1.80	1.50	7.13	10.24	0.89	13.92
	235	14	2	1.80	1.50	7.46	11.97	0.89	15.79
	300	18	2	1.80	1.50	8.12	11.97	0.89	15.59
	350	26	2	1.80	1.50	9.44	21.29	0.89	25.75
	400	30	2	1.80	1.50	10.10	24.50	0.89	27.07

### Enhanced Uplift

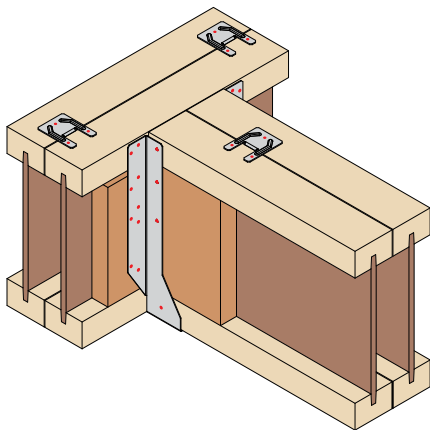

- Fill all red holes as indicated for this installation
- Fixings into the incoming joist are required to resist uplift
- Increased uplift figures can be achieved by nailing the additional triangular nail holes into the incoming member - solid incoming or web stiffeners are required

#### Load Data

Hanger Depth (mm)	Fixings (3.4 x 35mm)	Safe Working Loads (kN)		Characteristic Capacity (kN)
		Uplift - Short Term	Uplift - Long Term	
195 - 300	8	4.00	3.33	7.11
350 - 400	16	4.00	3.33	7.11

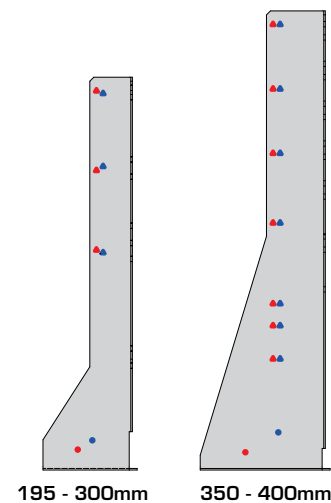

- Near side
- Far side

## Face Fix I-Joist Hanger

### I-Joist Incoming - I-Joist Header With Backer Block Installation Instructions

STAGE 1

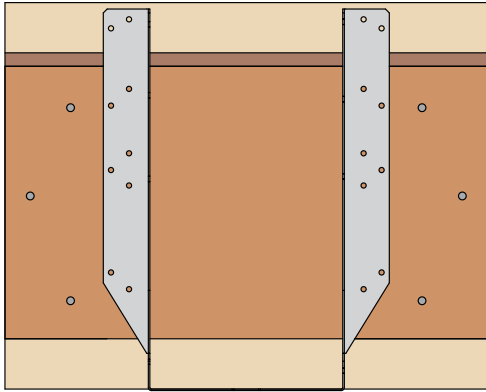

Position hanger flush with underside of joist.

Backer block installed as per I-Joist manufacturer's guidelines.

STAGE 2

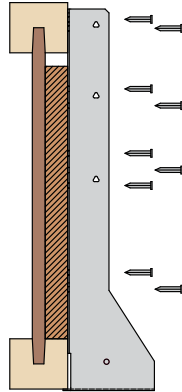

Circular nail holes filled from bottom to top ensuring hanger side flanges are plumb.

All fixings are 3.4 x 35mm square twist nails.

STAGE 3

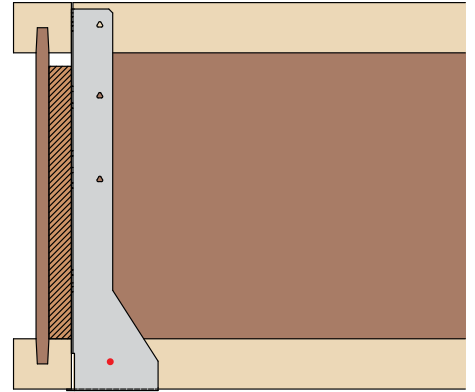

Once hanger is fully fixed the incoming joist is dropped into place and circular side nail holes are filled to secure incoming joist and complete installation.

2No fixings into bottom flange are required for standard installation.

Additional triangular holes into incoming joist only required for enhanced uplift (for details see page 65)

### I-Joist/Solid Incoming - Solid Header Installation Instructions

STAGE 1

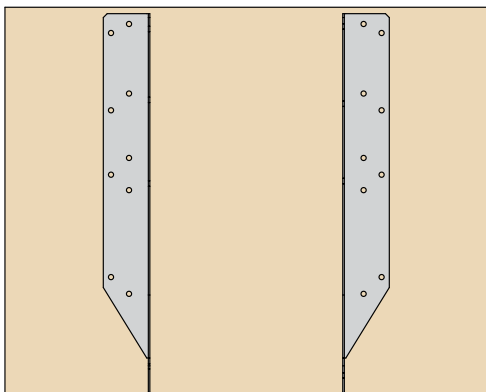

Position hanger flush with underside of joist.

STAGE 2

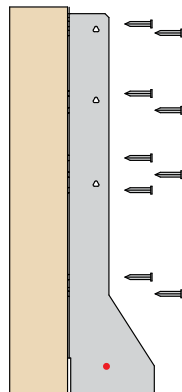

Circular nail holes filled from bottom to top ensuring hanger side flanges are plumb.

All fixings are 3.4 x 35mm square twist nails.

STAGE 3

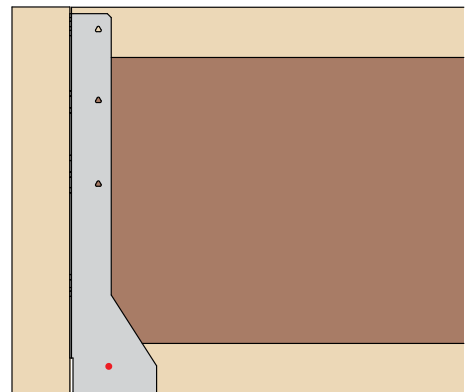

Once hanger is fully fixed the incoming joist is dropped into place and circular side nail holes are filled to secure incoming joist and complete installation.

2No circular bottom fixings are required for standard installation.

Additional triangular holes into incoming joist only required for enhanced uplift (for details see page 65)

# HUH (I-Joist Applications)



## Heavy Universal Hanger



The HUH hanger is designed for any joist to joist, joist to trimmer or joist to steel application in high load applications.

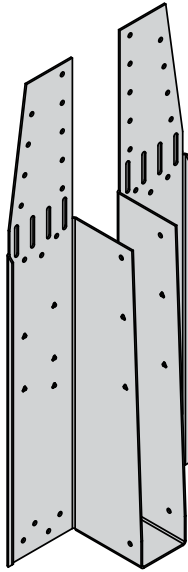

### Features & Benefits

- Elongated slots for height adjustment
- One hanger solution for backer and backerless I-Joists
- Additional triangular fixing holes for increased performance on solid members
- Suitable for connections to steel work - see pages 78 - 79

### Material Specification

- Galvanised mild steel - Z275

### Fixings

Code	Description	Box Qty
547389	3.4 x 35mm Square Twist Nails - LOOSE	500
141185	3.4 x 35mm Square Twist Nails - COLLATED*	2,500

\*For use with Paslode PPN35Ci

### Available Sizes

Hanger Width (W) (mm)	Hanger Depth (mm)					
	195	220	235	300	350	400
39	HUH-39-195	HUH-39-220	HUH-39-235	HUH-39-300	-	-
46	HUH-46-195	HUH-46-220	HUH-46-235	HUH-46-300	HUH-46-350	HUH-46-400
50	HUH-50-195	HUH-50-220	HUH-50-235	HUH-50-300	HUH-50-350	HUH-50-400
55	-	-	HUH-55-235	HUH-55-300	-	-
61	HUH-61-195	HUH-61-220	HUH-61-235	HUH-61-300	HUH-61-350	HUH-61-400
65	HUH-65-195	HUH-65-220	HUH-65-235	HUH-65-300	HUH-65-350	HUH-65-400
72	-	HUH-72-220	HUH-72-235	HUH-72-300	-	-
75	HUH-75-195	HUH-75-220	HUH-75-235	HUH-75-300	HUH-75-350	HUH-75-400
78	HUH-78-195	HUH-78-220	HUH-78-235	HUH-78-300	HUH-78-350	HUH-78-400
92	HUH-92-195	HUH-92-220	HUH-92-235	HUH-92-300	HUH-92-350	HUH-92-400
100	HUH-100-195	HUH-100-220	HUH-100-235	HUH-100-300	HUH-100-350	HUH-100-400
110	-	-	HUH-110-235	HUH-110-300	-	-
122	HUH-122-195	HUH-122-220	HUH-122-235	HUH-122-300	HUH-122-350	HUH-122-400
130	HUH-130-195	HUH-130-220	HUH-130-235	HUH-130-300	HUH-130-350	HUH-130-400
138	HUH-138-195	HUH-138-220	HUH-138-235	HUH-138-300	HUH-138-350	HUH-138-400
144	-	HUH-144-220	HUH-144-235	HUH-144-300	-	-
150	HUH-150-195	HUH-150-220	HUH-150-235	HUH-150-300	HUH-150-350	HUH-150-400
183	HUH-183-195	HUH-183-220	HUH-183-235	HUH-183-300	HUH-183-350	HUH-183-400
198	HUH-198-195	HUH-198-220	HUH-198-235	HUH-198-300	HUH-198-350	HUH-198-400
225	-	HUH-225-220	HUH-225-235	HUH-225-300	HUH-225-350	HUH-225-400

### Dimensions (mm)

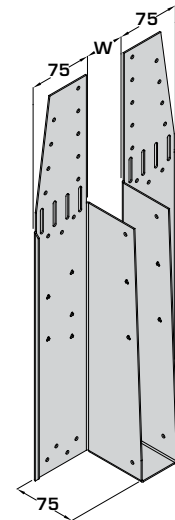

### Height Suitability

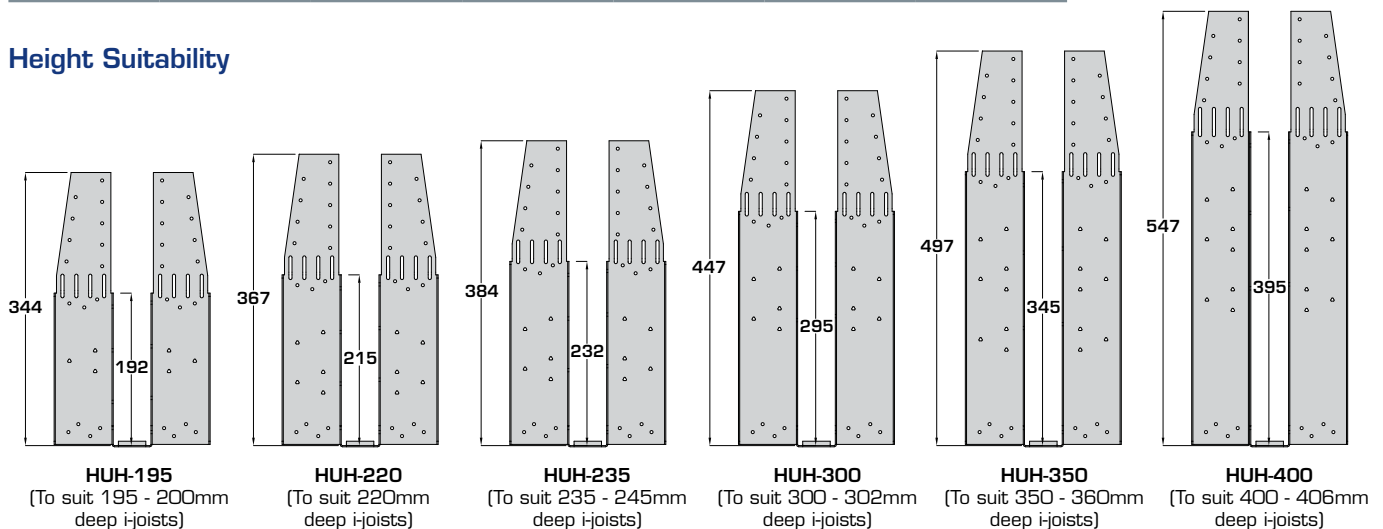

## Heavy Universal Hanger

### Standard Installation - I-Joist Header without Backer Block

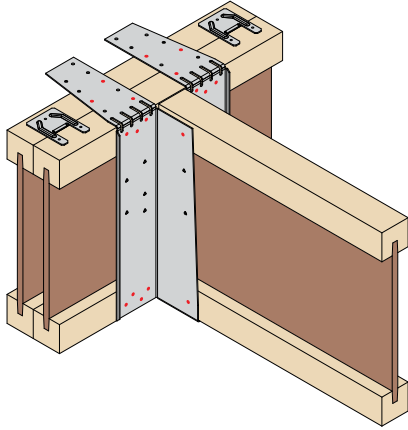

#### See Page 70 For Installation Instructions

- Fill all red holes as indicated for this installation
- No backer block required
- No web stiffeners required\*
- Top tabs to be wiped over and nailed
- Min 2No fixings into rear ply and 1No fixing into front ply per leg for double headers
- Additional triangular holes into face only required for solid headers

\*Additional triangular holes into incoming joist only required for enhanced uplift. (for details see page 69)

#### Load Data

Hanger Depth (mm) (Depth Dependent Only)	Fixings (3.4 x 35mm)			Safe Working Loads (kN)				Characteristic Capacity (kN)		
	Header		Incoming	Uplift - Short Term	Uplift - Long Term	I-Joist Header Long Term		Uplift	I-Joist Header	
	Face	Top				Solid Flange	LVL Flange		Solid Flange	LVL Flange
195	14	6	4	2.10	1.75	7.80	8.10	3.97	17.30	17.83
220	14	6	4	2.10	1.75	7.80	8.10	3.97	17.30	17.83
235	14	6	4	2.10	1.75	7.80	8.10	3.97	18.50	18.50
300	14	6	4	2.10	1.75	7.80	8.10	3.97	18.50	18.50
350	14	6	4	2.10	1.75	7.80	8.10	3.97	15.50	16.15
400	14	6	4	2.10	1.75	7.80	8.10	3.97	15.50	16.15

### Enhanced Installation - I-Joist Header with Backer Block

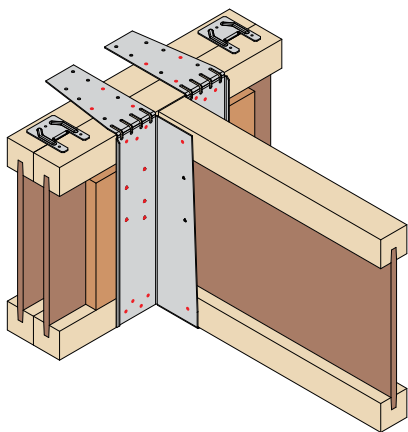

#### See Page 70 For Installation Instructions

- Fill all red holes as indicated for this installation
- All nail holes filled into backer block (including triangular)
- Backer block required to hanger side only (follow i-joist manufacturer's guidelines)
- Min 2No fixings into rear ply and 1No fixing into front ply per leg for double headers
- No web stiffeners required when using same hanger/joist depth\*

\*Additional triangular holes into incoming joist only required for enhanced uplift. (for details see page 69)

#### Load Data

Hanger Depth (mm) (Depth Dependent Only)	Fixings (3.4 x 35mm)			Safe Working Loads (kN)				Characteristic Capacity (kN)		
	Header		Incoming	Uplift - Short Term	Uplift - Long Term	I-Joist Header with Backer Block Long Term		Uplift	I-Joist Header	
	Face	Top				Solid Flange	LVL Flange		Solid Flange	LVL Flange
195	20	6	4	2.10	1.75	12.30	12.13	3.97	28.50	28.50
220	24	6	4	2.10	1.75	12.30	12.13	3.97	28.50	28.50
235	24	6	4	2.10	1.75	12.30	12.13	3.97	28.50	28.50
300	24	6	4	2.10	1.75	12.30	12.13	3.97	28.50	28.50
350	30	6	4	2.10	1.75	12.30	12.13	3.97	28.50	28.50
400	30	6	4	2.10	1.75	12.30	12.13	3.97	28.50	28.50

## Heavy Universal Hanger

### Enhanced Installation - Solid Header

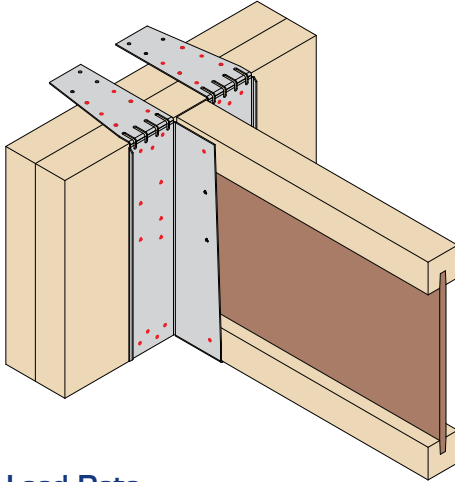

- Fill all red holes as indicated for this installation
- All nail holes filled into solid header (including triangular)
- No web stiffeners required when using same hanger/joist depth\*
- Top tabs to be wiped over and nailed
- Min 2No fixings into rear ply and 1No fixing into front ply per leg for double headers

\*Additional triangular holes into incoming joist only required for enhanced uplift. (for details see below)

#### Load Data

Hanger Depth (mm) (Depth Dependent Only)	Fixings (3.4 x 35mm)			Safe Working Loads (kN)				Characteristic Capacity (kN)		
	Header		Incoming	Uplift - Short Term	Uplift - Long Term	Solid Header		Uplift	Solid Header	
	Face	Top				Long Term			GL (Min GL28)	LVL
195	20	6	4	2.10	1.75	12.60	13.50	3.97	29.50	29.50
220	24	6	4	2.10	1.75	12.60	13.50	3.97	29.50	29.50
235	24	6	4	2.10	1.75	12.60	13.50	3.97	29.50	29.50
300	24	6	4	2.10	1.75	12.60	13.50	3.97	29.50	29.50
350	30	6	4	2.10	1.75	12.60	13.50	3.97	29.50	29.50
400	30	6	4	2.10	1.75	12.60	13.50	3.97	29.50	29.50

### Enhanced Uplift

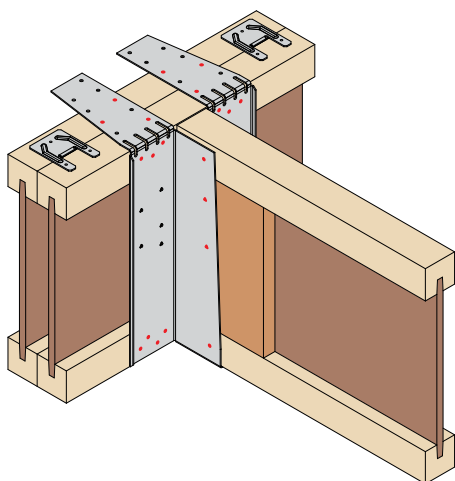

- Fill all red holes as indicated for this installation
- Fixings into the incoming joist are required to resist uplift
- Increased uplift figures can be achieved by nailing the additional triangular nail holes into the incoming member - solid incoming or web stiffeners are required

#### Load Data

Hanger Depth (mm) (Depth Dependent Only)	Fixings (3.4 x 35mm)	Safe Working Loads (kN)		Characteristic Capacity (kN)
	Incoming	Uplift - Short Term	Uplift - Long Term	Uplift
195 - 400	8	3.98	3.31	7.97

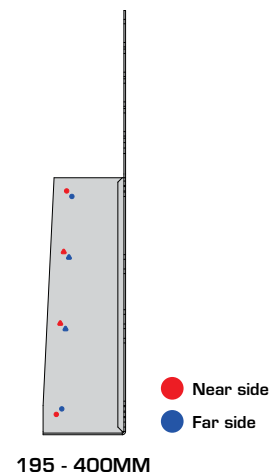

## Heavy Universal Hanger

### Standard Installation Instructions - I-Joist Header without Backer Block

STAGE 1

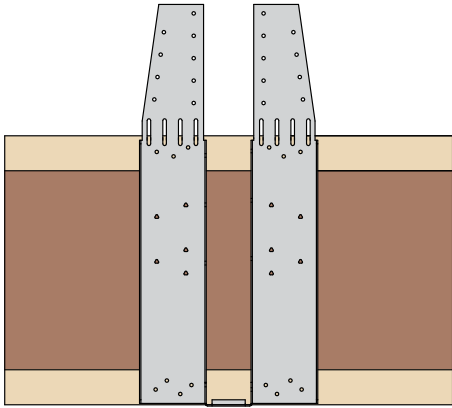

Position hanger flush with underside of joist.

STAGE 2

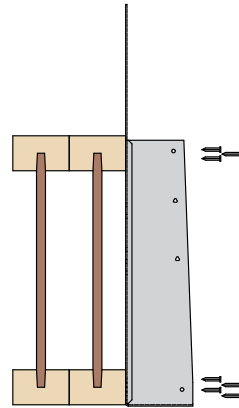

Face nail to top and bottom flanges using 14No 3.4 x 35mm square twist nails in total.

STAGE 3

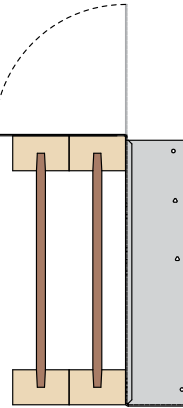

Wipe over top tabs to give a flush fit to the joist.

STAGE 4

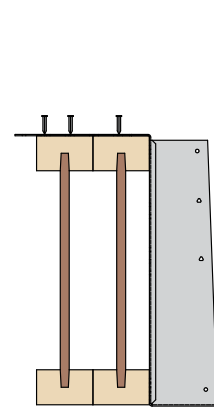

Nail top tabs into top flange of joist - Min 2No 3.4 x 35mm square twist nails into rear ply and 1No 3.4 x 35mm square twist nail into front ply per leg.

### Enhanced Installation Instructions - I-Joist Header with Backer Block

STAGE 1

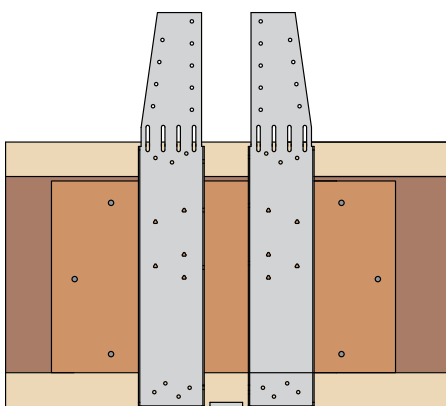

Position hanger flush with underside of joist.

Backer block installed as per I-Joist manufacturer's guidelines.

STAGE 2

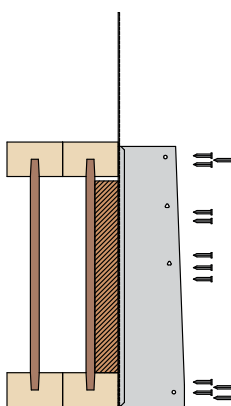

Fill all round and triangular nail holes to header and backer face with 3.4 x 35mm square twist nails.

STAGE 3

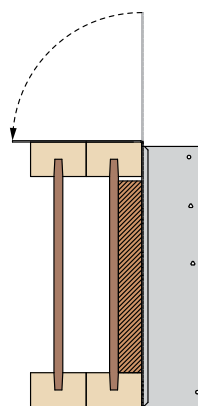

Wipe over top tabs to give a flush fit to the joist.

STAGE 4

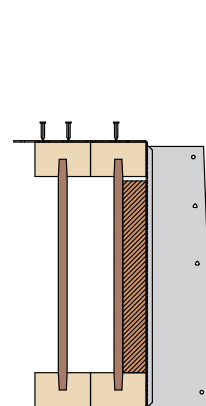

Nail top tabs into top flange of joist - Min 2No 3.4 x 35mm square twist nails into rear ply and 1No 3.4 x 35mm square twist nail into front ply per leg.

# HUH (Open Web Applications)



## Heavy Universal Hanger



The HUH hanger is designed for any joist to joist, joist to trimmer or joist to steel application in high load applications.

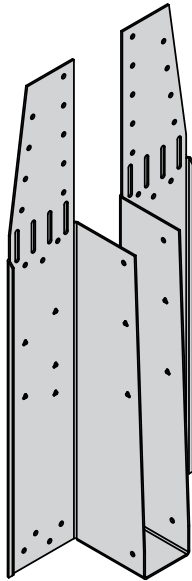

### Features & Benefits

- Elongated slots for height adjustment
- No need for plywood gussets or backer blocks
- Additional triangular fixing holes for increased performance on solid members
- Suitable for connections to steel work - see pages 78 - 79

### Material Specification

- Galvanised mild steel - Z275

### Fixings

Code	Description	Box Qty
547389	3.4 x 35mm Square Twist Nails - LOOSE	500
141185	3.4 x 35mm Square Twist Nails - COLLATED*	2,500

\*For use with Paslode PPN35Ci

### Available Sizes

Hanger Width (W) (mm)	Hanger Depth (mm)					
	195	220	235	300	375	400
39	HUH-39-195	HUH-39-220	HUH-39-235	HUH-39-300	HUH-39-375	HUH-39-400
46	HUH-46-195	HUH-46-220	HUH-46-235	HUH-46-300	HUH-46-375	HUH-46-400
75	HUH-75-195	HUH-75-220	HUH-75-235	HUH-75-300	HUH-75-375	HUH-75-400
78	HUH-78-195	HUH-78-220	HUH-78-235	HUH-78-300	-	HUH-78-400
92	HUH-92-195	HUH-92-220	HUH-92-235	HUH-92-300	HUH-92-375	HUH-92-400
100	HUH-100-195	HUH-100-220	HUH-100-235	HUH-100-300	HUH-100-375	HUH-100-400
125	HUH-125-195	HUH-125-220	HUH-125-235	HUH-125-300	HUH-125-375	HUH-125-400
138	HUH-138-195	HUH-138-220	HUH-138-235	HUH-138-300	HUH-138-375	HUH-138-400
150	HUH-150-195	HUH-150-220	HUH-150-235	HUH-150-300	HUH-150-375	HUH-150-400
198	HUH-198-195	HUH-198-220	HUH-198-235	HUH-198-300	HUH-198-375	HUH-198-400
225	-	HUH-225-220	HUH-225-235	HUH-225-300	HUH-225-375	HUH-225-400
250	-	HUH-250-220	HUH-250-235	HUH-250-300	HUH-250-375	HUH-250-400
300	-	HUH-300-220	HUH-300-235	HUH-300-300	HUH-300-375	HUH-300-400

### Dimensions (mm)

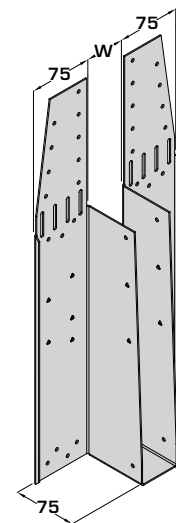

### Height Suitability

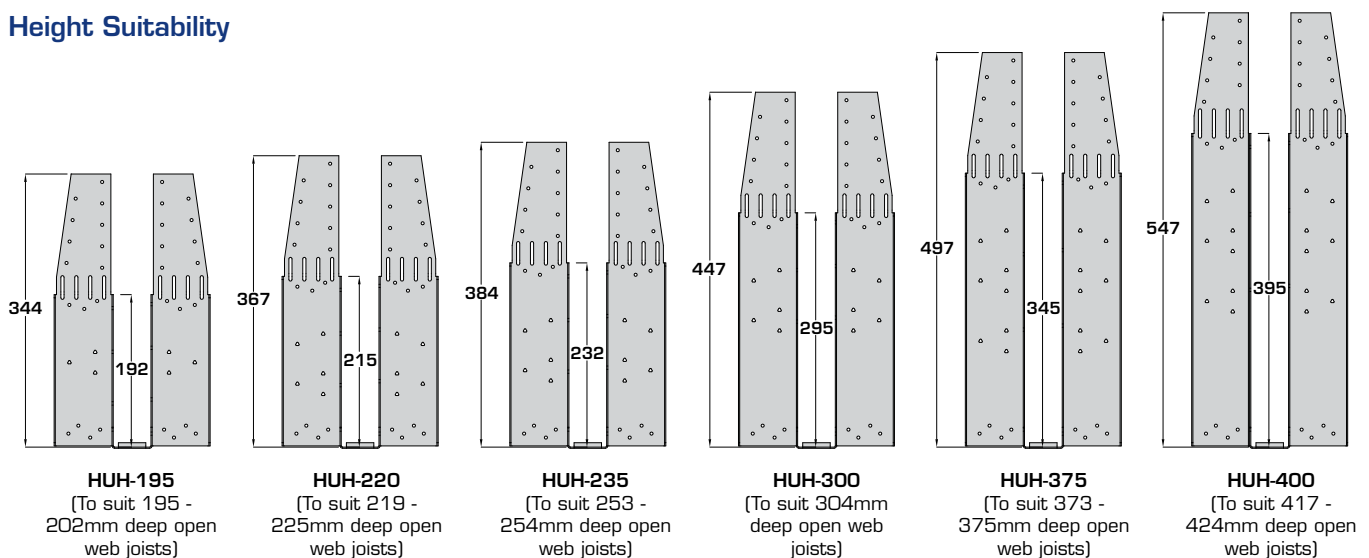

## Heavy Universal Hanger

### Standard Installation - Open Web Header

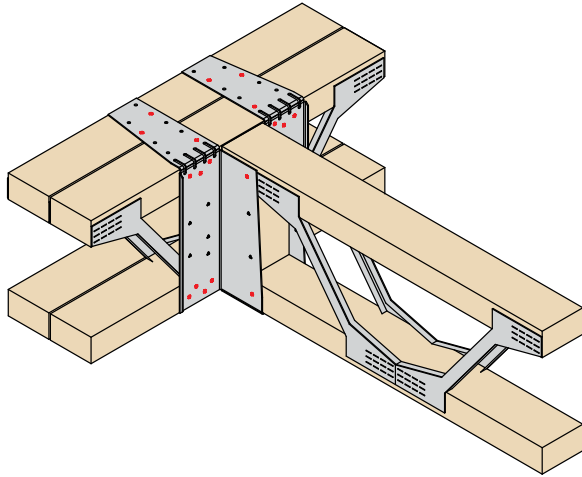

#### See Page 75 For Installation Instructions

- Fill all red holes as indicated for this installation
- No backer block/plywood gusset required
- Top tabs to be wiped over and nailed
- Min 2No fixings into rear ply and 1No fixing into front ply per leg for double headers
- Additional triangular holes into face only required for solid headers

Additional triangular holes into incoming joist only required for enhanced uplift. (for details see page 74)

#### Load Data

Hanger Depth (mm) (Depth Dependent Only)	Fixings (3.4 x 35mm)			Safe Working Loads (kN)			Characteristic Capacity (kN)	
	Header		Incoming	Uplift - Short Term	Uplift - Long Term	Open Web Header Long Term	Uplift	Open Web Header
	Face	Top						
195	14	6	4	2.10	1.75	7.56	3.97	13.95
220	14	6	4	2.10	1.75	7.56	3.97	13.95
235	14	6	4	2.10	1.75	7.56	3.97	18.60
300	14	6	4	2.10	1.75	7.56	3.97	18.60
375	14	6	4	2.10	1.75	7.56	3.97	18.60
400	14	6	4	2.10	1.75	7.56	3.97	18.60

### Standard Installation With Blocking - Open Web Header

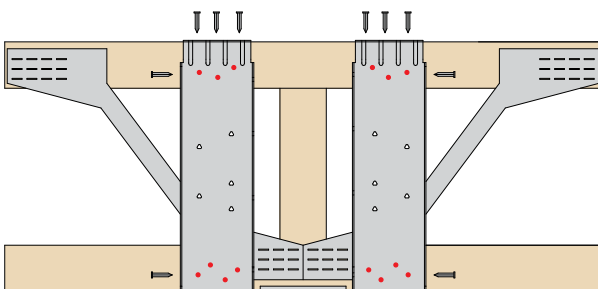

#### See Page 76 For Installation Instructions

- Fill all red holes as indicated for this installation
- Blocking piece required within joist, centred on hanger and minimum 47 x 72mm
- No backer block/plywood gusset required
- Top tabs to be wiped over and nailed
- Min 2No fixings into rear ply and 1No fixing into front ply per leg for double headers

Additional triangular holes into incoming joist only required for enhanced uplift. (for details see page 74)

#### Load Data

Hanger Depth (mm) (Depth Dependent Only)	Fixings (3.4 x 35mm)			Safe Working Loads (kN)			Characteristic Capacity (kN)	
	Header		Incoming	Uplift - Short Term	Uplift - Long Term	Open Web Header With Blocking Long Term	Uplift	Open Web Header With Blocking
	Face	Top						
195	14	6	4	2.10	1.75	10.69	3.97	24.00
220	14	6	4	2.10	1.75	10.69	3.97	24.00
235	14	6	4	2.10	1.75	10.69	3.97	24.00
300	14	6	4	2.10	1.75	10.69	3.97	24.00
375	14	6	4	2.10	1.75	10.69	3.97	24.00
400	14	6	4	2.10	1.75	10.69	3.97	24.00



## Heavy Universal Hanger

### Enhanced Installation - Solid Header

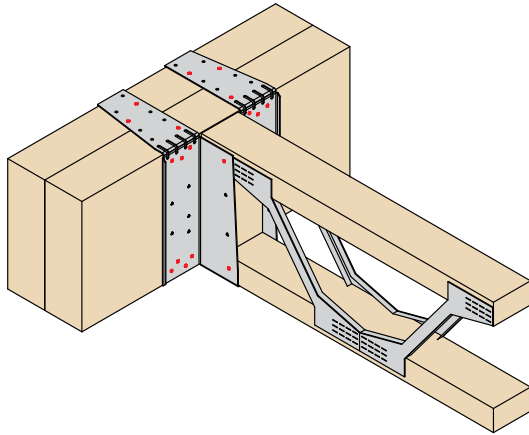

#### See Page 75 For Installation Instructions

- Fill all red holes as indicated for this installation
- All nail holes filled into plywood gusset (including triangular)
- Top tabs to be wiped over and nailed
- Min 2No fixings into rear ply and 1No fixing into front ply per leg for double headers

Additional triangular holes into incoming joist only required for enhanced uplift. (for details see page 74)

#### Load Data

Hanger Depth (mm) (Depth Dependent Only)	Fixings (3.4 x 35mm)			Safe Working Loads (kN)				Characteristic Capacity (kN)		
	Header		Incoming	Uplift - Short Term	Uplift - Long Term	Solid Header		Uplift	Solid Header	
	Face	Top				Long Term			GL (Min GL28)	LVL
			GL (Min GL28)	LVL	GL (Min GL28)	LVL				
195	20	6	4	2.10	1.75	12.60	13.50	3.97	29.50	29.50
220	24	6	4	2.10	1.75	12.60	13.50	3.97	29.50	29.50
235	24	6	4	2.10	1.75	12.60	13.50	3.97	29.50	29.50
300	24	6	4	2.10	1.75	12.60	13.50	3.97	29.50	29.50
375	30	6	4	2.10	1.75	12.60	13.50	3.97	29.50	29.50
400	30	6	4	2.10	1.75	12.60	13.50	3.97	29.50	29.50

### Enhanced Installation - Open Web Header With Plywood Gusset

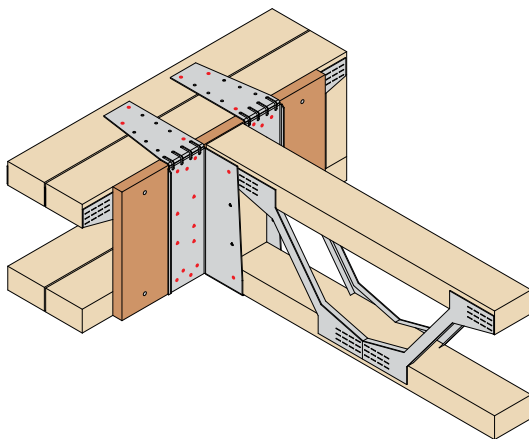

#### See Page 77 For Installation Instructions

- Fill all red holes as indicated for this installation
- 18mm plywood gusset should be screwed into open web header with the appropriate screws - see installation instructions for more information
- All nail holes filled into plywood gusset (including triangular)
- Top tabs to be wiped over and nailed
- Min 2No fixings into rear ply and 1No fixing into front ply per leg for double headers

Additional triangular holes into incoming joist only required for enhanced uplift. (for details see page 74)

#### Load Data

Hanger Depth (mm) (Depth Dependent Only)	Fixings (3.4 x 35mm)			Safe Working Loads (kN)			Characteristic Capacity (kN)	
	Header		Incoming	Uplift - Short Term	Uplift - Long Term	Open Web Header / 18mm Plywood Gusset	Uplift	Open Web Header / 18mm Plywood Gusset
	Face	Top						
			GL (Min GL28)	LVL				
195	20	6	4	2.10	1.75	12.60	3.97	29.50
220	24	6	4	2.10	1.75	12.60	3.97	29.50
235	24	6	4	2.10	1.75	12.60	3.97	29.50
300	24	6	4	2.10	1.75	12.60	3.97	29.50
375	30	6	4	2.10	1.75	12.60	3.97	29.50
400	30	6	4	2.10	1.75	12.60	3.97	29.50

## Heavy Universal Hanger

### Enhanced Uplift

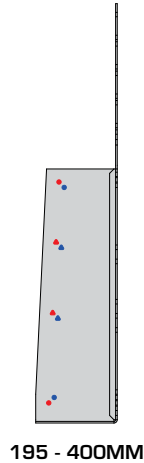
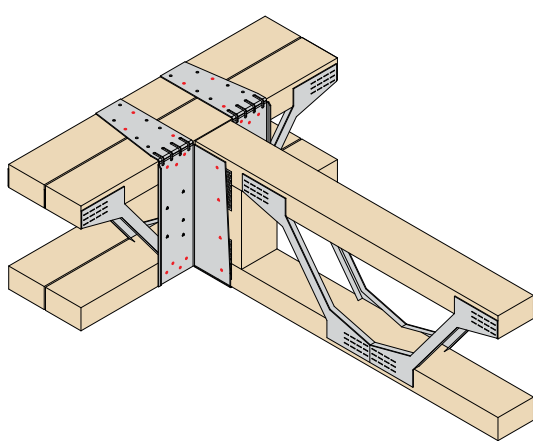

- Fill all red holes as indicated for this installation
- Fixings into the incoming joist are required to resist uplift
- Increased uplift figures can be achieved by nailing the additional triangular nail holes into the incoming member - solid incoming or full width vertical required

● Near side  
● Far side

195 - 400MM

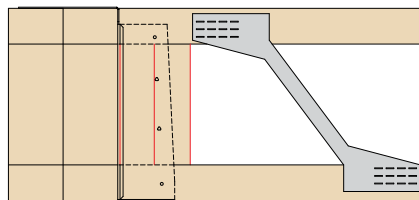

Hanger side flanges/plates omitted for clarity

2 No end verticals required to achieve full uplift capacity.

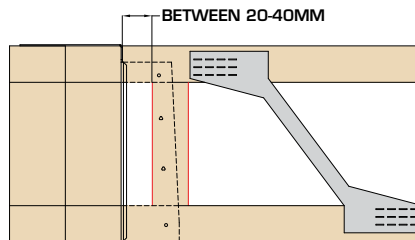

Hanger side flanges/plates omitted for clarity

Single end verticals can be used if the gap between the back of the hanger and the vertical is between 20 - 40mm.



**Incorrect Installation**

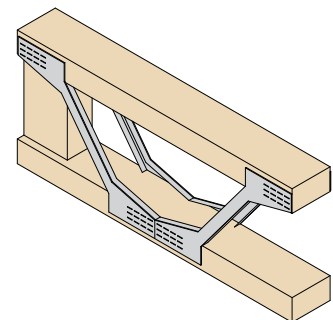

Do not use HUH for enhanced uplift when using trimmable ends

### Load Data

Hanger Depth (mm) (Depth Dependent Only)	Fixings (3.4 x 35mm) Incoming	Safe Working Loads (kN)		Characteristic Capacity (kN)
		Uplift - Short Term	Uplift - Long Term	Uplift
195 - 400	8	3.98	3.31	7.97

## Heavy Universal Hanger

### Standard Installation Instructions - Open Web Header

STAGE 1

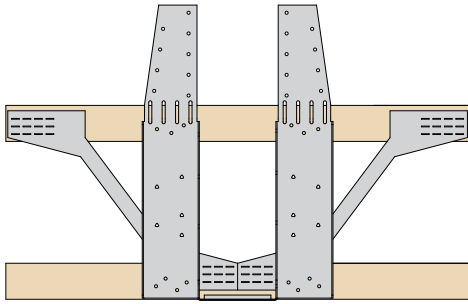

Position hanger flush with underside of joist.

STAGE 2

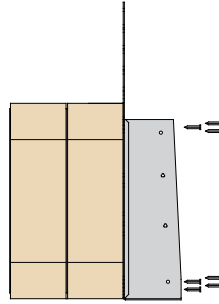

Face nail to top and bottom chords using 14No 3.4 x 35mm square twist nails in total.

STAGE 3

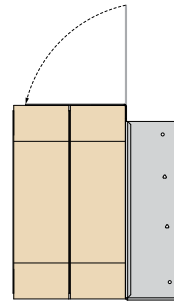

Wipe over top tabs to give a flush fit to the joist.

STAGE 4

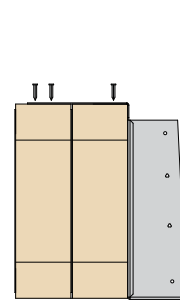

Nail top tabs into top chord of joist - Min 2No 3.4 x 35mm square twist nails into rear ply and 1No 3.4 x 35mm square twist nail into front ply per leg.

### Enhanced Installation Instructions - Solid Header

STAGE 1

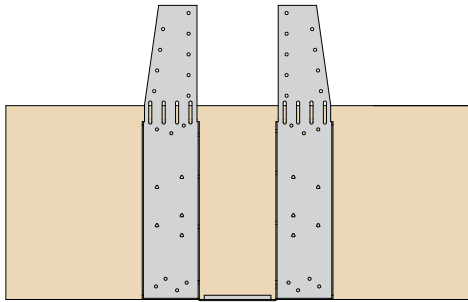

Position hanger flush with underside of joist.

STAGE 2

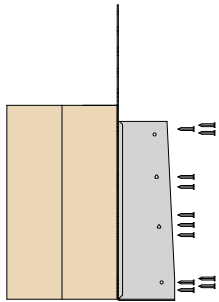

Fill all round and triangular nail holes to header joist with 3.4 x 35mm square twist nails.

STAGE 3

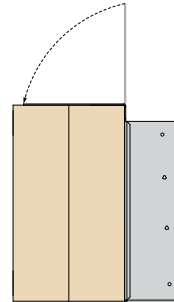

Wipe over top tabs to give a flush fit to the joist.

STAGE 4

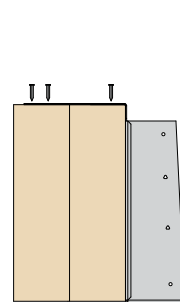

Nail top tabs into top chord of joist - Min 2No 3.4 x 35mm square twist nails into rear ply and 1No 3.4 x 35mm square twist nail into front ply per leg.

## Heavy Universal Hanger

### Standard Installation With Blocking Instructions - Open Web Header

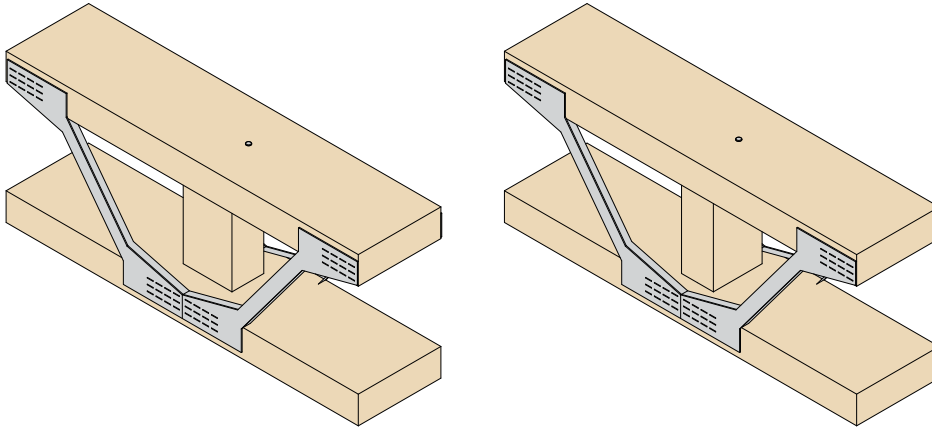

Applying a high load to the top flange of an open web joist can lead to failure of the joist itself (i.e metal webs buckling)

Adding a vertical blocking piece to the open web joist prevents buckling and helps transfer the load, therefore allowing the hanger to perform to a greater capacity.

STAGE 1

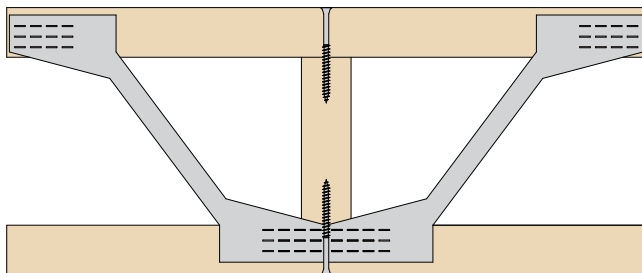

Vertical blocking piece to be built into Open Web Joist, centred on incoming hanger position.

Vertical blocking piece to be minimum 47 x 72mm C16 timber.

Fixed using Paslode 3.1 x 90mm annular ring shank nails.

STAGE 2

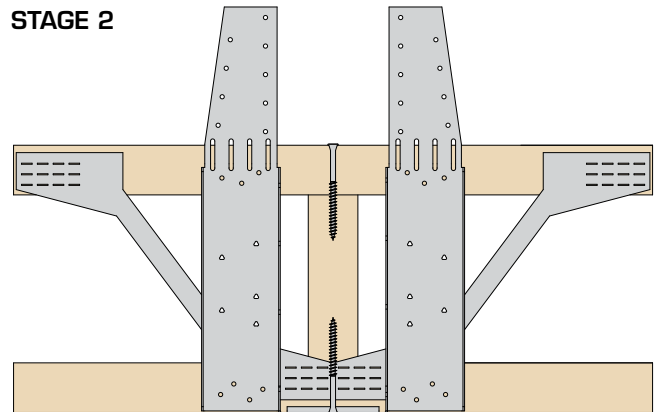

Position hanger against face of Open Web Joist with locating tab tight to underside of joist.

STAGE 3

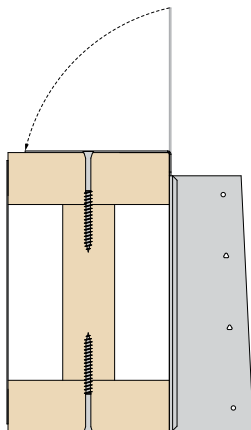

Wipe over top tabs to give a flush fit to the joist.

STAGE 4

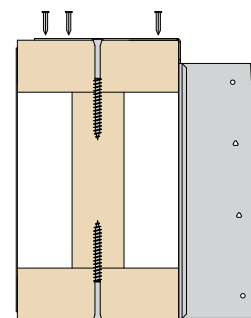

Nail top tabs into top chord of joist - Min 2No 3.4 x 35mm square twist nails into rear ply and 1No 3.4 x 35mm square twist nail into front ply per leg.

## Heavy Universal Hanger

### Open Web Header With Plywood Gusset Instructions

#### STAGE 1

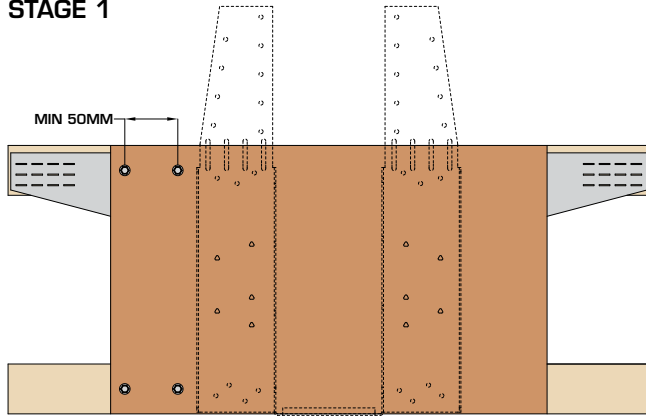

18mm plywood should be fixed to the face of the open web joist with 4No PSTS 6.5mm into the top chord and 4No PSTS 6.5mm into the bottom chord.

Plywood should be the full depth of the open web and of a width to give the screws the appropriate edge distance.

Paslode Structural Timber Screws should be used to fix the plywood to the open web joist. The screw length is dependant on the joist thickness.

#### STAGE 2

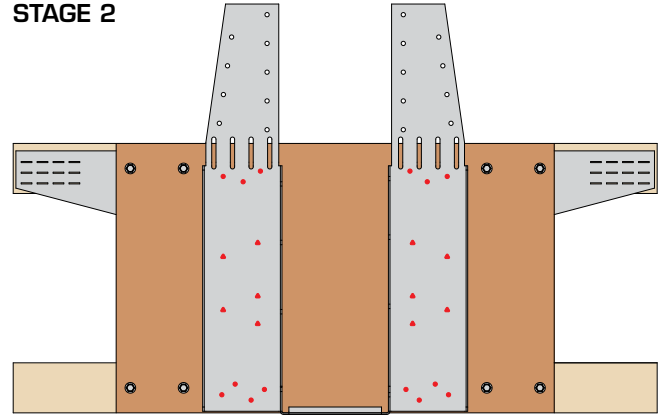

Position hanger flush with underside of joist.

Circular nail holes filled from bottom to top ensuring hanger side flanges are plumb.

All fixings are 3.4 x 35mm square twist nails.

Triangular nail holes should also be filled.

#### STAGE 3

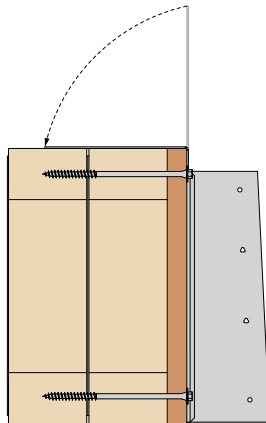

Wipe over top tabs to give a flush fit to the joist.

#### STAGE 4

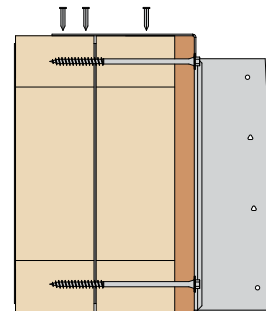

Nail top tabs into top chord of joist - Min 2No 3.4 x 35mm square twist nails into rear ply and 1No 3.4 x 35mm square twist nail into front ply per leg.

### Screw Specification

Header Joist Thickness	Fixing Ref	Product Code	Box Qty
Single 72mm	PSTS6.5X65	551105	100
Single 97mm	PSTS6.5X100	551106	100
Single 122mm	PSTS6.5X100	551106	100
Single 147mm	PSTS6.5X115	551102	100
Double 72mm	PSTS6.5X150	551107	100
Double 97mm	PSTS6.5X200	551108	100
Double 122mm	PSTS6.5X200	551108	100
Double 147mm	PSTS6.5X250	551109	100

## TIMBER HANGER CONNECTIONS

### Top Fixed To Timber Packer

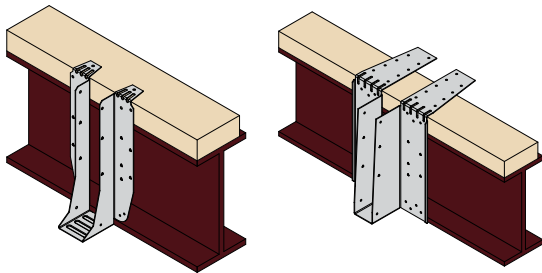

Hanger fixed to timber packer secured to top of steel beam using 3.4 x 35mm square twist nails. Hanger must be deeper than steel beam to prevent hanger rotation. Timber packers must be a minimum of 35 x 72mm C16 grade timber.

Product Code	Fixings		Safe Working Loads (kN) - Long Term	Characteristic Capacity (kN)
	Face	Top		
UH	4	2	4.50	10.80
HUH	6	6	6.60	13.20

### Top & Face Fixed To Timber Packer

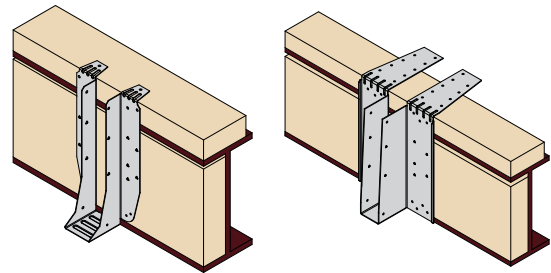

Hanger fixed to timber packer secured to top flange and web of steel beam using 3.4 x 35mm square twist nails. Timber packer fixed to web of beam (as per Building Designers instructions) to prevent hanger rotation. Timber packers must be a minimum of 35 x 72mm C16 grade timber.

Product Code	Fixings		Safe Working Loads (kN) - Long Term	Characteristic Capacity (kN)
	Face	Top		
UH	14	2	6.40	12.80
HUH	24	6	11.07	23.30

### Top Fixed To Steel Beam

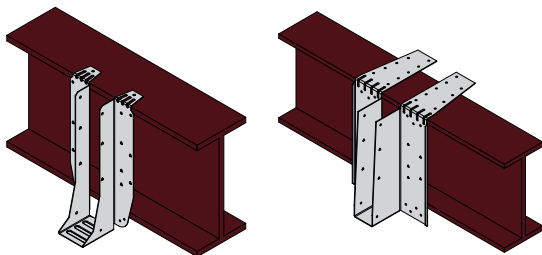

Hanger fixed directly to top flange of steel beam using SPIT P370 Cartridge tool using SC9 nails or equivalent, into the hanger flanges. Hanger must be deeper than steel to prevent hanger rotation.

**!** UH hanger must not be folded on the snap line.

Product Code	Fixings		Safe Working Loads (kN) - Long Term	Characteristic Capacity (kN)
	Face	Top		
UH	0	2	4.50	10.80
HUH	0	6	6.60	13.20

### Top Fixed To Steel Beam & Face Fixed To Timber Packer

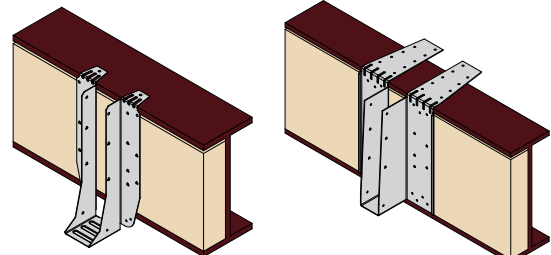

Hanger fixed directly to top flange of steel beam using SPIT P370 Cartridge tool using SC9 nails or equivalent, into the hanger flanges. Hanger fixed to timber packer secured to web of steel beam using 3.4 x 35mm square twist nails. Timber packer fixed to web of beam (as per Building Designers instructions) to prevent hanger rotation. Timber packers must be a minimum of 35 x 72mm C16 grade timber.

Product Code	Fixings		Safe Working Loads (kN) - Long Term	Characteristic Capacity (kN)
	Face	Top		
UH	14	2	6.40	12.80
HUH	24	6	11.07	23.30

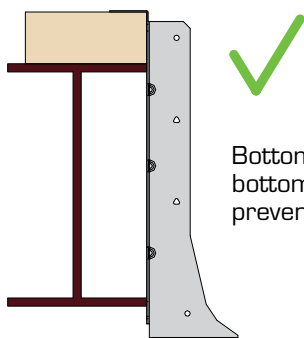

Bottom of hanger extends past bottom flange of steel beam to prevent hanger rotation.

### Preventing Hanger Rotation - "Do's and Don'ts"

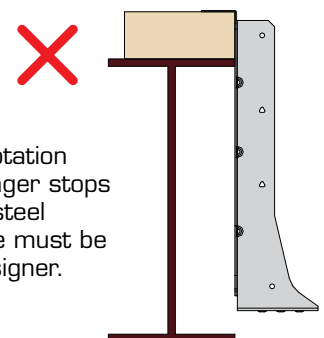

There is no resistance to rotation when the bottom of the hanger stops short of the bottom of the steel beam. Timber packing piece must be specified by the building designer.

## TIMBER HANGER CONNECTIONS

### UH Hanger - Face Fixed Only To Timber Packer Within Steel Beam

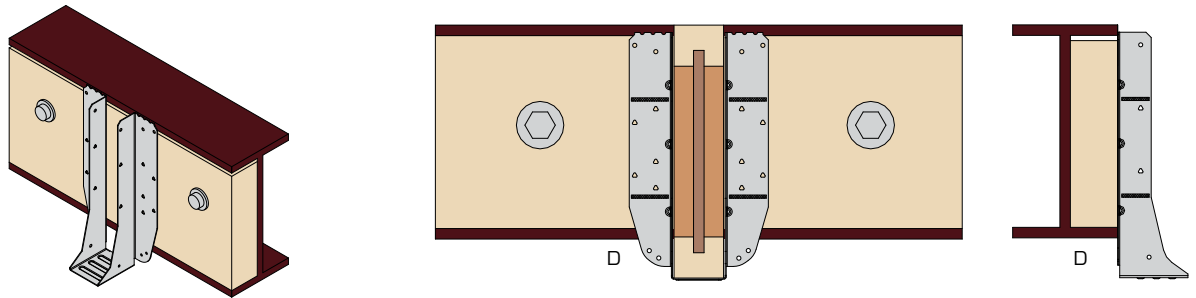

Timber packer to be securely fixed to web of steel beam, packer to be fixed tightly to bottom flange of steelwork.

Dropped dimension 'D' must not be greater than 30% of the overall joist depth.

Timber Packer to be a minimum of C16 grade timber.

Fixing of timber packer to steelwork by Building Designer.

### UH Performance - Connection to Steelwork

Product Code	Hanger Dimensions			Fixings		Safe Working Loads (kN) - Long Term			Characteristic Capacity (kN)		
	W	H	B	Face	Joist	Uplift - Short Term	Enhanced Uplift (Fully Nailed) Short Term	Fixing To Solid Timber (Min C16)	Uplift	Enhanced Uplift (Fully Nailed)	Fixing To Solid Timber (Min C16)
UH-46-195	46	190	65	10	2	1.80	4.00	6.20	0.89	7.11	12.40*
UH-46-220	46	215	65	14	2	1.80	4.00	6.20	0.89	7.11	12.40*
UH-46-235	46	230	65	14	2	1.80	4.00	6.60	0.89	7.11	13.20*
UH-46-300	46	295	65	18	2	1.80	4.00	7.60	0.89	7.11	15.20*
FFI-46-350	46	345	65	26	2	1.80	4.00	9.40	0.89	7.11	18.80*
FFI-46-400	46	395	65	30	2	1.80	4.00	10.10	0.89	7.11	20.20*

\*Values obtained from tests carried out by ITW Construction Products and calculated in accordance with ETAG 015.

Enhanced uplift capacity can be achieved by using additional triangular nail holes in the side flanges and fixing web stiffeners where the incoming joist is an I-joist. When using web stiffeners for this purpose ensure the I-joist manufacturer's fixing guidelines are followed.

## MASONRY HANGER CONNECTIONS

### Top Fixed To Steel Beam

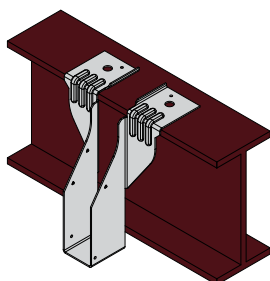

Hanger fixed directly to top flange of steel beam using Spit Spitfire P370 Cartridge tool using SC9 nails or equivalent, into the hanger flanges. Hanger must be deeper than steel to prevent rotation.

Product Code	Fixings		Safe Working Loads (kN) - Long Term	Characteristic Capacity (kN)
	Face	Top		
JHI	0	4	7.54	13.97

### Top Fixed To Steel Beam

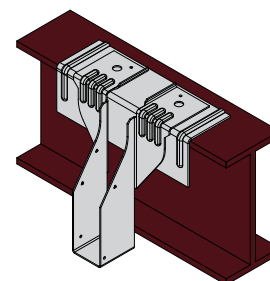

Hanger fixed directly to top flange of steel beam using Spit Spitfire P370 Cartridge tool using SC9 nails or equivalent, into the hanger flanges. Hanger must be deeper than steel to prevent rotation.

Product Code	Fixings		Safe Working Loads (kN) - Long Term	Characteristic Capacity (kN)
	Face	Top		
RB-JHI	0	4	15.73	28.31

# MH RANGE



## Multi Hanger

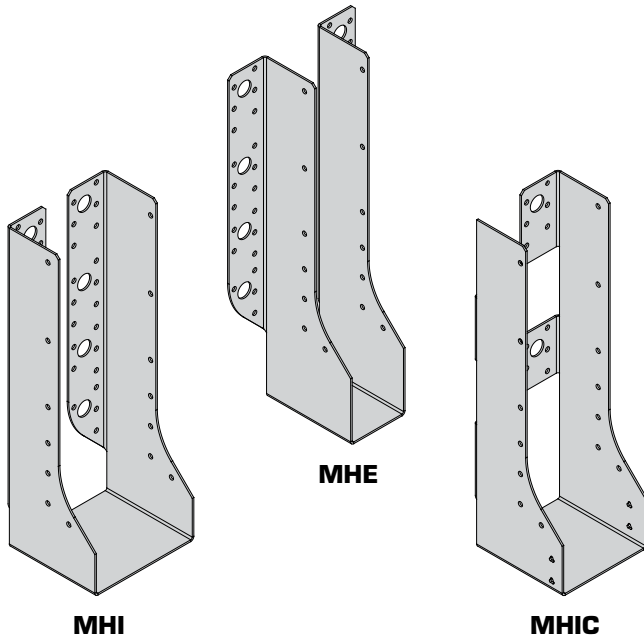

The MH hanger range is designed to support timber to timber connections in medium to high load situations.

### Features & Benefits

- External and internal flange options allow for multifunctional use
- Range of sizes and potential fixing options allows for greater design flexibility
- Partial fixing options available on request. Contact Technical Support.

### Material Specification

- Galvanised mild steel - Z275

### Fixings

Code	Description	Box Qty
547389	3.4 x 35mm Square Twist Nails - LOOSE	500
141185	3.4 x 35mm Square Twist Nails - COLLATED*	2,500
See page 10	M12 Bolts	Each

\*For use with Paslode PPN35Ci

### Available Sizes

Hanger Width (W) (mm)	MHE280	MHI280	MHE380	MHI/MHIC380	MHE490	MHI/MHIC490	MHE620	MHI/MHIC620
39	MHE280-39-120	-	MHE380-39-170	MHIC380-39-170	MHE490-39-225	MHIC490-39-225	MHE620-39-290	MHIC620-39-290
46	MHE280-46-117	-	MHE380-46-167	MHIC380-46-167	MHE490-46-222	MHIC490-46-222	MHE620-46-287	MHIC620-46-287
50	MHE280-50-115	-	MHE380-50-165	MHIC380-50-165	MHE490-50-220	MHIC490-50-220	MHE620-50-285	MHIC620-50-285
55	-	-	-	-	MHE490-55-217	MHIC490-55-217	MHE620-55-282	MHIC620-55-282
61	-	-	MHE380-61-159	MHIC380-61-159	-	MHIC490-61-214	-	MHIC620-61-279
65	-	-	-	MHIC380-65-157	-	MHIC490-65-212	MHE620-65-277	MHIC620-65-277
72	-	-	-	MHIC380-72-154	-	MHIC490-72-209	-	MHIC620-72-274
75	MHE280-75-102	-	MHE380-75-152	MHIC380-75-152	MHE490-75-207	MHIC490-75-207	MHE620-75-272	MHIC620-75-272
78	-	-	MHE380-78-151	MHIC380-78-151	MHE490-78-206	MHIC490-78-206	MHE620-78-271	MHIC620-78-271
92	-	-	MHE380-92-144	MHI380-92-144	MHE490-92-199	MHI490-92-199	MHE620-92-264	MHI620-92-264
100	MHE280-100-90	MHI280-100-90	MHE380-100-140	MHI380-100-140	MHE490-100-195	MHI490-100-195	MHE620-100-260	MHI620-100-260
110	-	-	-	-	MHE490-110-190	MHI490-110-190	MHE620-110-255	MHI620-110-255
118	-	-	MHE380-118-131	MHI380-118-131	MHE490-118-186	MHI490-118-186	-	-
122	-	-	-	-	MHE490-122-184	MHI490-122-184	MHE620-122-249	MHI620-122-249
125	-	-	-	-	MHE490-125-182	MHI490-125-182	MHE620-125-247	MHI620-125-247
130	-	-	-	-	-	-	MHE620-130-245	MHI620-130-245
135	-	-	-	-	MHE490-135-177	MHI490-135-177	-	-
138	-	-	-	-	MHE490-138-176	MHI490-138-176	MHE620-138-241	MHI620-138-241
144	-	-	-	-	-	MHI490-144-173	MHE620-144-238	-
150	-	-	MHE380-150-115	MHI380-150-115	MHE490-150-170	MHI490-150-170	MHE620-150-235	MHI620-150-235

Hanger Width (W) (mm)	MHE620	MHI620	MHE670	MHI670	MHE720	MHI720
183	MHE620-183-218	MHI620-183-218	-	-	-	-
198	MHE620-198-211	MHI620-198-211	-	-	-	-
210	-	-	MHE670-210-230	-	-	-
225	-	-	MHE670-225-222	MHI670-225-222	-	-
230	-	-	MHE670-230-220	-	-	-
250	-	-	MHE670-250-210	MHI670-250-210	-	-
275	-	-	-	-	MHE720-275-222	MHI720-275-222
300	-	-	-	-	MHE720-300-210	MHI720-300-210

Example: **MHIC620-50-285**  
L W H  
 L = length  
 W = width  
 H = height



The hanger depth must be at least 60% of the carried member depth to prevent rotation, unless additional lateral restraint is added to the top of the carried member. Contact your system provider for further information on providing restraint.



# MH RANGE



## Multi Hanger

### Hanger Coding

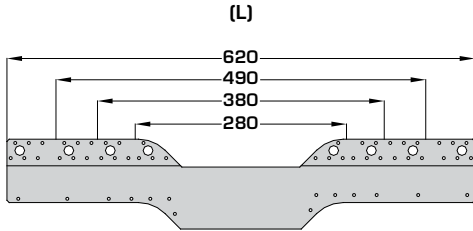

**MHE/MHI FLAT BLANK**  
(280 - 620)

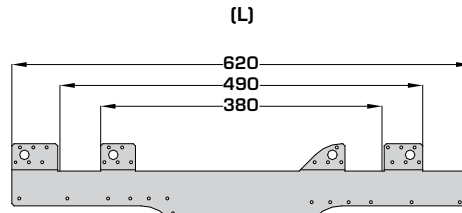

**MHIC FLAT BLANK**

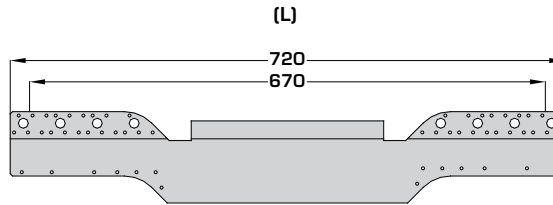
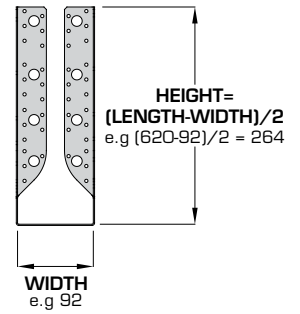

**MHE/MHI FLAT BLANK**  
(670 - 720)

Example: **MHI620-92-264**  
L W H  
L = length  
W = width  
H = height

### Dimensions (mm)

MHE

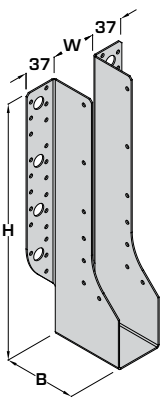

MHI/MHIC

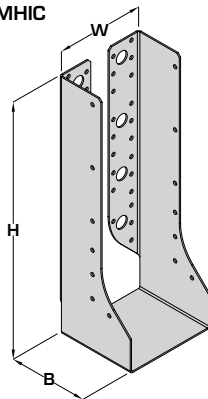

### In Situ

MHI/MHIC Installed on I-Joist Header With Backer Block

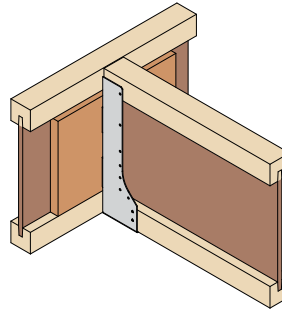

MHE Installed on Open Web Header With Plywood Gusset

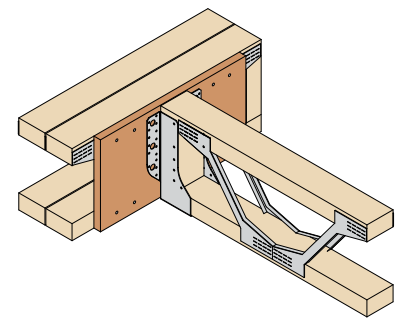

### Load Data

Product Code	Dimensions (mm)			Fixings (3.4 x 35mm)		Safe Working Loads (kN)			Characteristic Capacity (kN)		
	W		B	Header	Incoming	Uplift - Short Term	Long Term		Uplift	I-Joist Header With Backer Block (Solid/LVL Flange)	Open Web Header With Plywood Gusset
	Min	Max					I-Joist Header With Backer Block (Solid/LVL Flange)	Open Web Header With Plywood Gusset			
MHE/MHI280	39	100	85	8	6	2.54	4.27	4.27	4.67	10.12	10.12
MHE/MHI380	39	150	85	18	10	4.43	8.26	8.26	8.49	20.07	20.07
MHE/MHI490	39	100	85	30	12	7.71	12.35	12.35	14.72	25.66	25.66
MHE/MHI490	110	150	85	30	12	7.71	10.53	10.53	14.72	25.66	25.66
MHE/MHI620	39	100	85	42	14	8.26	14.83	14.83	14.72	32.77	32.77
MHE/MHI620	110	150	85	42	14	8.26	12.08	12.08	14.72	25.92	25.92
MHE/MHI620	183	198	85	42	14	8.26	14.83	14.83	14.72	32.77	32.77
MHE/MHI670	210	250	85	42	14	8.26	14.83	14.83	14.72	32.77	32.77
MHE/MHI720	275	300	85	42	14	8.26	14.83	14.83	14.72	32.77	32.77
MHIC380	39	78	82	9	10	4.43	5.43	5.43	8.49	10.55	10.55
MHIC490	39	78	82	16	12	7.71	8.96	8.96	14.72	16.76	16.76
MHIC620	39	78	82	21	14	8.26	10.34	10.34	14.72	21.26	21.26

## Mini Hanger

**NEW & IMPROVED FOR 2017**

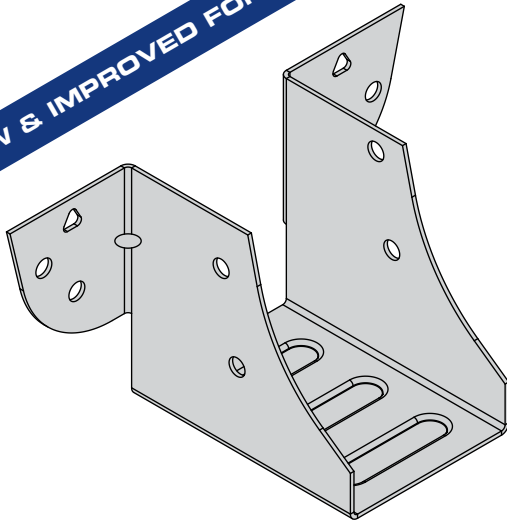

The KM hanger is used to support joists where a compact economical connector is required.

### Features & Benefits

- New and improved design achieves higher load carrying capacities
- Additional side fixings allow for increased uplift capacity
- Optional triangular holes for increased performance on solid headers
- Rear location tab to assist with installation

### Material Specification

- Galvanised mild steel - Z275

### Approvals

- Meets NHBC Technical Requirements

### Fixings

Code	Description	Box Qty
547389	3.4 x 35mm Square Twist Nails - LOOSE	500
141185	3.4 x 35mm Square Twist Nails - COLLATED*	2,500

\*For use with Paslode PPN35Ci

### Available Sizes

Product Code	Hanger Width (W) (mm)	Hanger Depth (H) (mm)
KM-50	50	43

### Dimensions (mm)

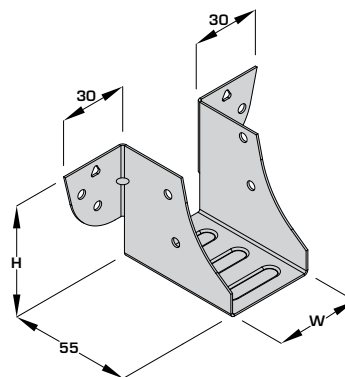

### In Situ

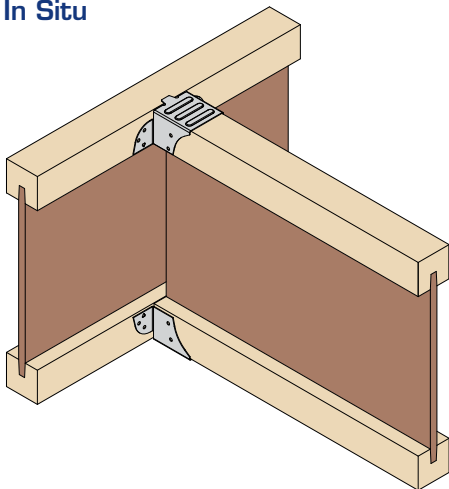

### Load Data

Product Code	Fixings (3.4 x 35mm)		Safe Working Loads (kN)			Characteristic Capacity (kN)**	
	Header	Incoming	Uplift - Short Term	Long Term		Uplift	I-Joist (LVL/Solid Flange)
				I-Joist (LVL/Solid Flange)	LVL/GL		
KM-50	4	4	2.50	2.10	2.40	5.16	5.16

\*\*Values obtained from tests carried out by ITW Construction Products and calculated in accordance with ETAG 015

Values apply to new design only. Please contact Technical Support for further information if required.

## Flexible Timber Hanger

The FTHI hanger is designed to support joists, trussed rafters and solid timber members in a top fix only application for high load situations.

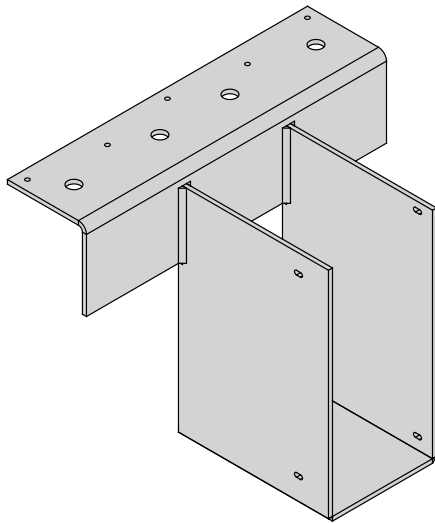

### Features & Benefits

- Increased top flange to allow for greater load distribution
- Options available for skewed, offset, dropped and straddle connections

### Material Specification

- 4mm mild steel with zinc phosphate undercoat with an organic bituminous top coat to BS EN845-1:2013+A1:2016

### Fixings

Code	Description	Box Qty
547389	3.4 x 35mm Square Twist Nails - LOOSE	500
141185	3.4 x 35mm Square Twist Nails - COLLATED*	2,500

\*For use with Paslode PPN35Ci

### Available Sizes

#### Hanger Widths (mm):

39, 46, 50, 61, 65, 72, 75, 78, 92, 100, 122, 125, 130, 138, 144, 150, 183, 198, 222, 225, 250, 300

#### Hanger Depths (mm):

140, 165, 195, 200, 210, 220, 225, 230, 235, 241, 245, 253, 280, 302, 350, 356, 380, 393, 400, 418, 450

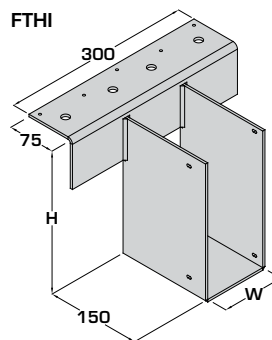

FTHI-W-H

Example:  
FTHI-100-245

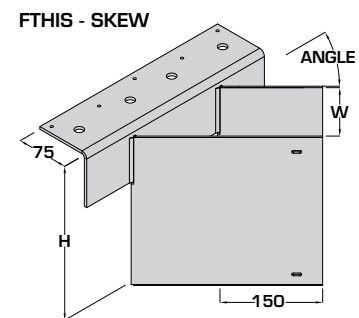

FTHIS-W-H-OFFSET DIRECTIONAL-ANGLE

Example:  
FTHIS-100-245-L-45

#### FTHIO - OFFSET

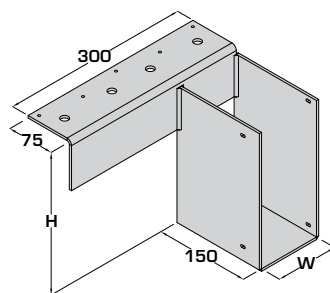

Left hand version shown

FTHIO-W-H-OFFSET DIRECTION

Example:  
FTHIO-100-245-L  
FTHIO-100-245-R

#### FTHID - DROPPED

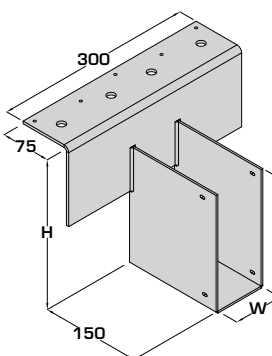

FTHID-W-H-F

Example:  
FTHID-100-245-220

#### FTHIST - STRADDLE

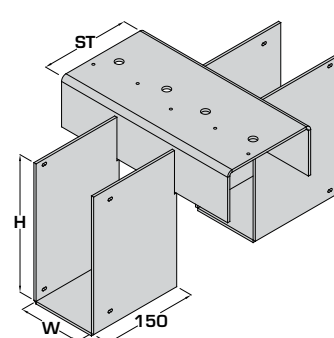

FTHIST-W-H-ST

Example:  
FTHIST-100-245-140

### Load Data

Product Code	Fixings (3.4 x 35mm)		Safe Working Loads (kN)			Characteristic Capacity (kN)	
	Header	Incoming	Uplift	LVL or GL (Min GL28)		Uplift	LVL or GL (Min GL28)
				Long Term	Medium Term		
FTHI	5	2	1.00	22.85	25.55	2.00	42.00

## Variable Skewed Timber Hanger

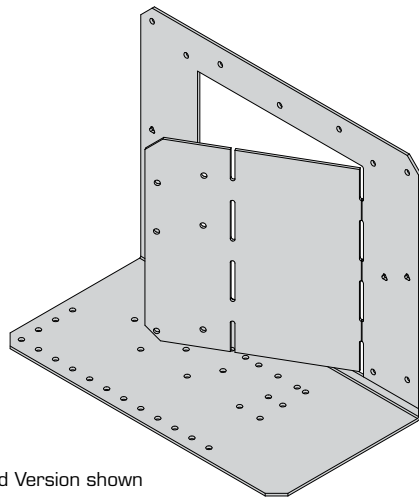

Right Hand Version shown

The VS hanger is used to support joists and trusses up to 97mm wide from solid timber members in skewed applications between 30 - 90°.

### Features & Benefits

- Unique hanger design provides a variable skew angle between 30 - 90°
- No need to mitre cut joists
- Angle scale on base to ease adjustment

### Material Specification

- Galvanised mild steel - Z275

### Fixings

Code	Description	Box Qty
547389	3.4 x 35mm Square Twist Nails - LOOSE	500
141185	3.4 x 35mm Square Twist Nails - COLLATED*	2,500

\*For use with Paslode PPN35Ci

### Available Sizes

Min Joist Width (mm)	Max Joist Width (mm)	Handing	Hanger Depth (mm)			
			195	220	240	300
38	97	Right	VS-195-R	VS-220-R	VS-240-R	VS-300-R
38	97	Left	VS-195-L	VS-220-L	VS-240-L	VS-300-L
>97		See FTHIS on page 83				

### Dimensions (mm)

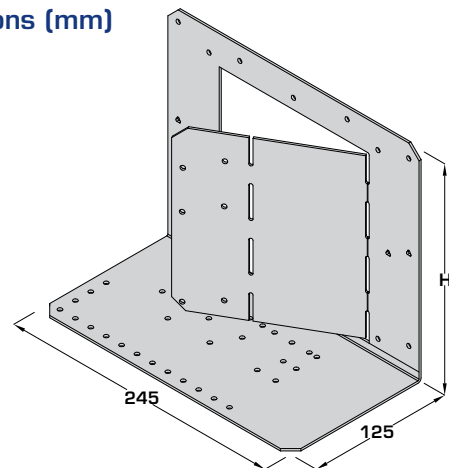

### Left Hand

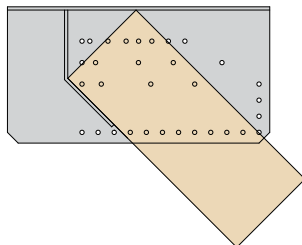

### Right Hand

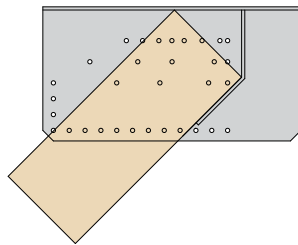

### In Situ

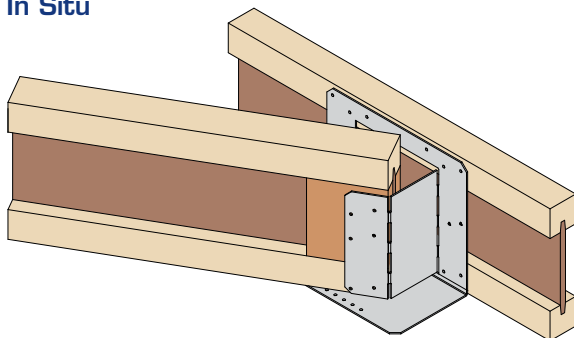

- Web stiffeners required for incoming I-Joist
- Backer blocks only required for enhanced capacity

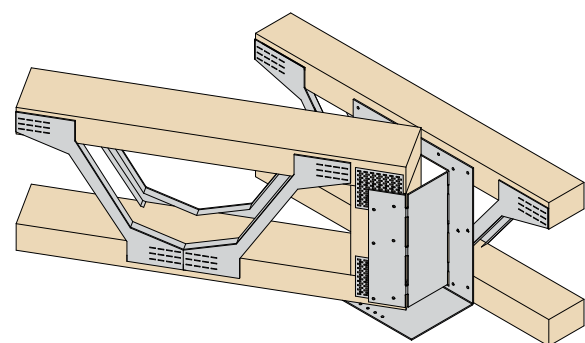

- Adequate end blocking required to allow fixings into incoming Open Web Joist

Joist Depth (mm)	Hanger Depth (mm)
195/200	195
220/235	220
240/245	240
300	300

Joist Depth (mm)	Hanger Depth (mm)
195/202	195
219/225	220
253/254	240
304	300

## Variable Skewed Timber Hanger

### Load Data

Hanger Depth (mm)	Fixings (3.4 x 35mm)		Safe Working Loads (kN)			Characteristic Capacity (kN)		
	Header	Incoming	Uplift - Short Term	Long Term		Uplift	I-Joist Header (all flanges)	Open Web Header
				I-Joist Header (all flanges)	Open Web Header			
195/220/240	11	6	2.50	4.16	4.16	3.75	5.90	5.90
300	11	6	2.50	4.16	4.16	3.75	6.39	6.39
195/220/240/300	15	6	2.50	5.17	5.17	3.75	6.37	7.23 (7.28*)

### Installation Instructions

#### STAGE 1

Adjust side plate to approximate angle between 30° and 90° using scale on base of hanger, bending only once. Please refer to the angle table below to determine if one or two bends are required.

Single Bend	Joist Width (mm)	Single bend	Double Bend
	35	n/a	30-90°
	38	n/a	30-90°
	44	n/a	30-90°
	45	n/a	30-90°
	47	n/a	30-90°
	51	30-32°	>32-90°
	53	30-32°	>32-90°
	58	30-34°	>34-90°
	59	30-34°	>34-90°
	60	30-34°	>35-90°
	63	30-37°	>37-90°
	70	30-39°	>39-90°
	72	30-40°	>40-90°
	76	30-42°	>42-90°
	88	30-46°	>46-90°
	89	30-46°	>46-90°
	90	30-46°	>46-90°
	94	30-48°	>48-90°
	97	30-49°	>49-90°

#### STAGE 2

Position hanger against face of joist/truss and face nail using 11(15\*)No nails in total.

\*For solid headers

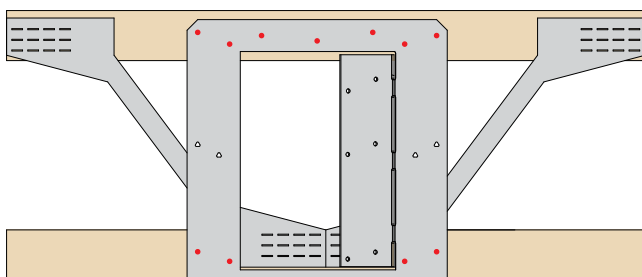

#### STAGE 3

Locate incoming member and adjust side plate to correct angle, ensuring maximum gap between incoming joist/truss and back plate is no greater than 3mm.

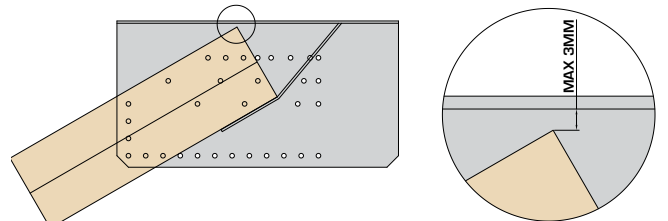

Max - 3mm gap at any given time

#### STAGE 4

Fix to incoming member using 6No 3.4 x 35mm square twist nails. Where incoming member is an I-Joist, web stiffeners must be fixed as per the I-Joist manufacturer's guidelines.

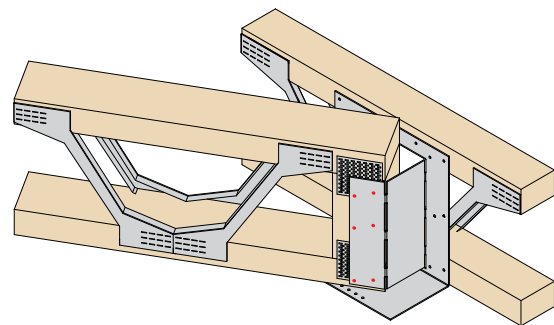

Please ensure that 1No inner nail hole (indicated in red) and 1No outer nail hole (indicated in red) are filled on the underside with 3.4 x 35mm square twist nails.

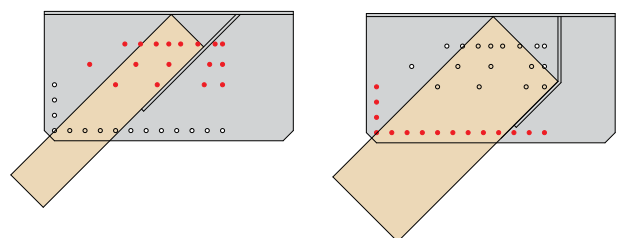

## Variable Ridge Connector



The VRC connects solid timber and I-Joist rafters to ridge beams.

### Features & Benefits

- Innovative design allows the part to be flexible for slopes between  $-35^\circ$  and  $+45^\circ$  and skews between  $30^\circ$  and  $90^\circ$

### Material Specification

- Galvanised mild steel - Z275

### Fixings

Code	Description	Box Qty
547389	3.4 x 35mm Square Twist Nails - LOOSE	500
141185	3.4 x 35mm Square Twist Nails - COLLATED*	2,500

\*For use with Paslode PPN35Ci

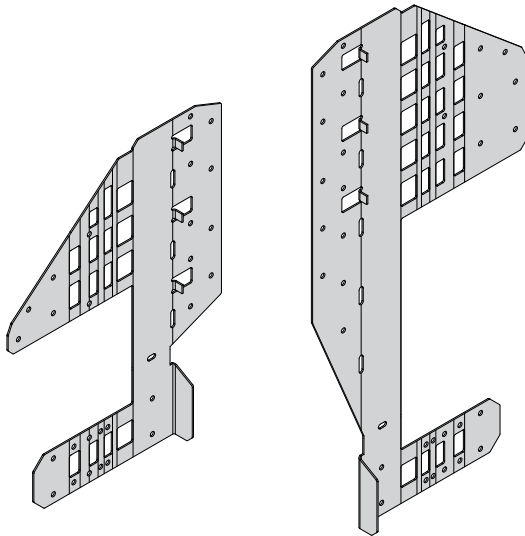

VRC-195-L

VRC-350-R

### Dimensions (mm)

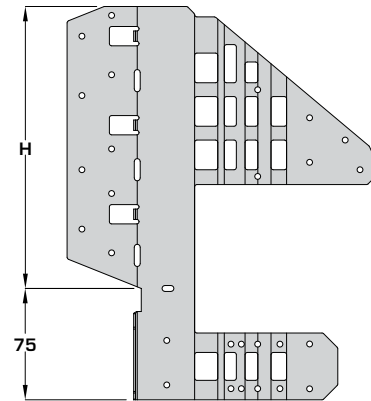

### Available Sizes

Min Joist Width (mm)	Max Joist Width (mm)	Handing	Timber Depth (mm)	
			195 - 300	350 - 450
38	97	Right	VRC-195-R	VRC-350-R
38	97	Left	VRC-195-L	VRC-350-L
>97		-	Contact Cullen Technical	

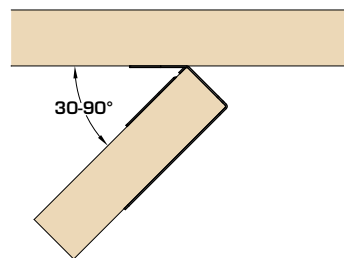

Right hand skew

(skews between  $30^\circ$ - $90^\circ$ )

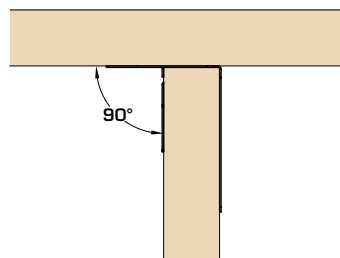

90 degrees

(left or right hand can be specified)

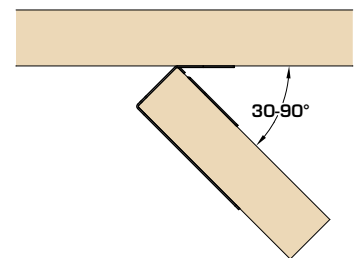

Left hand skew

(skews between  $30^\circ$ - $90^\circ$ )

### In Situ

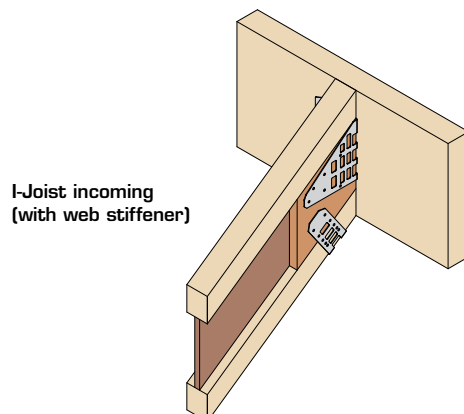

I-Joist incoming  
(with web stiffener)

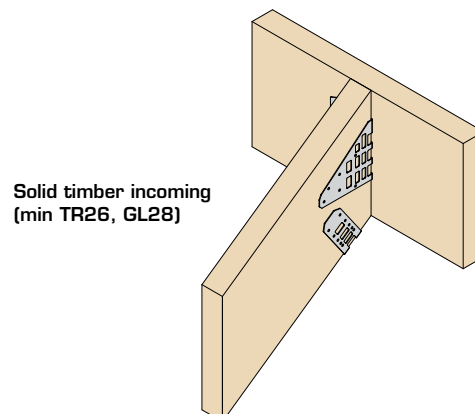

Solid timber incoming  
(min TR26, GL28)

## Variable Ridge Connector

### Load Data

Hanger Depth (mm)	Dimensions (mm)	Fixings (3.4x35mm)		Angles		Safe Working Loads (kN)		Characteristic Capacity (kN)	
						Uplift - Short Term	Long Term	Uplift	Header Specification
							Header Specification		Solid Timber (Min TR26), Glulam (Min GL28), LVL & I-Joist <sup>(1)</sup>
(Depth Dependant Only)	H	Header	Incoming	Slope	Skew				
195	190	9	8	0°	n/a (90°)	2	4.00	2.59	6.85
				0°	30° to 87.5°	2	4.00	2.59	6.40
				(-35° to +45°)	n/a (90°)	2	4.00	2.59	10.20
				(-35° to +45°)	30° to 87.5°	2	4.00	2.59	8.54
350	345	12	8	0°	n/a (90°)	2	4.00	2.59	6.85
				0°	30° to 87.5°	2	4.00	2.59	6.40
				(-35° to +45°)	n/a (90°)	2	4.00	2.59	10.20
				(-35° to +45°)	30° to 87.5°	2	4.00	2.59	8.54

<sup>(1)</sup> I-Joist headers require backer blocks to be installed as per joist manufacturer's instructions.

### Installation Instructions

#### STAGE 1

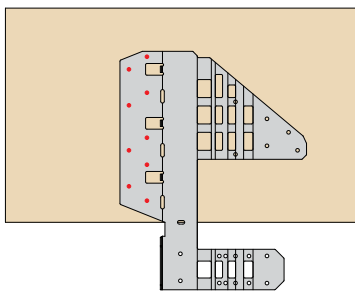

Face fix VRC to solid header using 9No 3.4 x 35mm square twist nails.

Adjust angle of base plate if slope is required.

#### STAGE 2

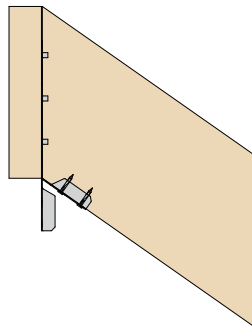

Offer incoming member and fix using 2No 3.4 x 35mm square twist nails to the underside of the incoming member.

#### STAGE 3

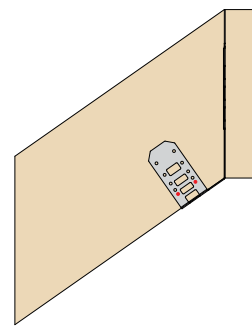

Wipe up the bottom side flange at the appropriate crease line and fill the 2No nail holes closest to the bend line with 3.4 x 35mm square twist nails.

#### STAGE 4

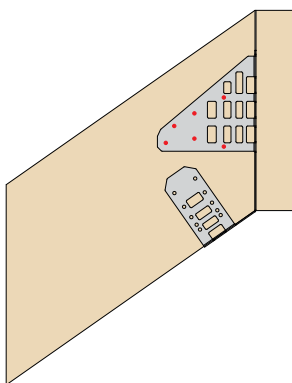

Wipe round the top side flange at the appropriate crease line and fill all the nail holes into the incoming joist. Minimum 4No 3.4 x 35mm square twist nails.

#### STAGE 5 (For skewed applications only)

Right hand version

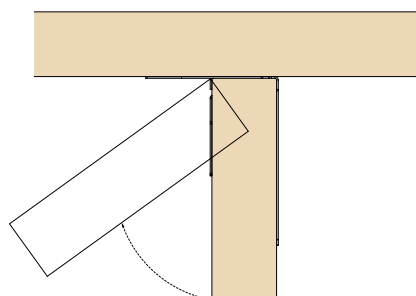

Left hand version

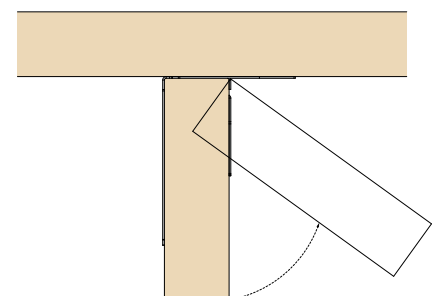

Rotate hanger to angle required. Correct hand must be used. Please ensure the correct hanger has been selected prior to installing.

## Adjustable Connector Eaves

The ACE is used to provide a secure connection between the EWP rafter and the wall plate at the eaves.

### Features & Benefits

- Eliminates the need for a bevelled wall plate
- Unique part design allows 2 parts to accommodate rafter widths between 38 - 97mm wide

### Material Specification

- Galvanised mild steel - Z275

### Fixings

Code	Description	Box Qty
547389	3.4 x 35mm Square Twist Nails - LOOSE	500
141185	3.4 x 35mm Square Twist Nails - COLLATED*	2,500

\*For use with Paslode PPN35CI

### Dimensions (mm)

#### ACE-39-50

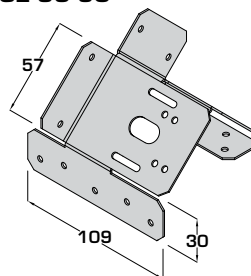

#### ACE-61-100

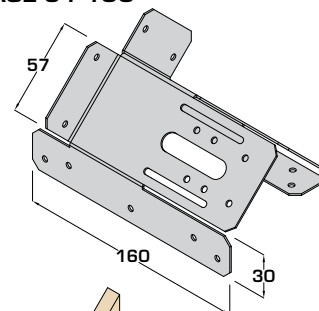

### Available Sizes

Product Code	Min Rafter Width (mm)	Max Rafter Width (mm)
ACE-39-50	38	47
ACE-61-100	58	97

### Installation Instructions

#### STAGE 1

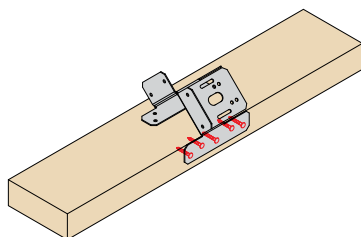

Position the ACE to the outside of the wall plate and nail to the face with 5No 3.4 x 35mm square twist nails.

#### STAGE 2

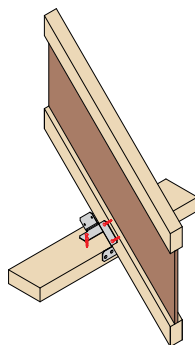

Position the I-Joist rafter and fix into the bottom flange with 2No 3.4 x 35mm square twist nails. On the same side fix into the top of the wall plate with 2No 3.4 x 35mm square twist nails.

#### STAGE 3

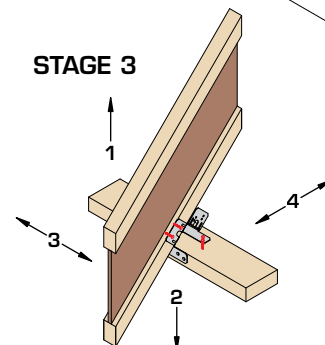

On the opposite side the ACE should be wiped up and nailed into the bottom flange with 2No 3.4 x 35mm square twist nails.

An additional 2No 3.4 x 35mm square twist nails should be fixed into the top of the wall plate.

### Load Data

Product Code	Fixings (3.4 x 35mm)		Safe Working Loads (kN)			Characteristic Capacity (kN)**
	Wallplate	Supported	Load Direction	Solid Timber Header (Min C16)		
				Medium Term	Short Term	
ACE-39-50	9	4	1	1.39	1.46	2.92
			2	4.49	4.71	5.64
			3	1.29	1.36	2.72
			4	1.39	1.39	2.78
ACE-61-100	9	4	1	1.39	1.46	2.92
			2	4.49	4.71	6.10
			3	1.29	1.36	2.72
			4	1.39	1.39	2.78

\*\*Values obtained from tests carried out by ITW Construction Products and calculated in accordance with ETAG 015.



# 45L/R



## Face Fix 45° Hanger

The 45L/R is a pre-skewed 45 degree hanger for timber to timber connections.

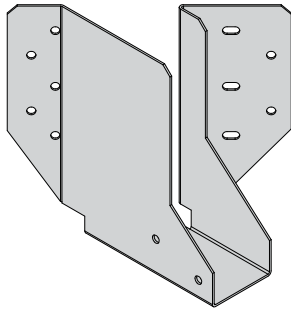

170mm Deep

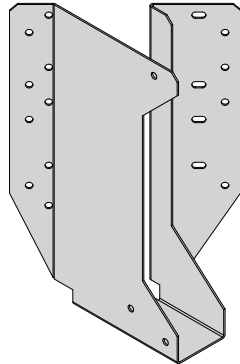

220 - 300mm Deep

Left hand version shown

### Features & Benefits

- Economical solution provides set angle for ease of installation

### Material Specification

- Galvanised mild steel - Z275

### Fixings

Code	Description	Box Qty
547389	3.4 x 35mm Square Twist Nails - LOOSE	500
141185	3.4 x 35mm Square Twist Nails - COLLATED*	2,500

\*For use with Paslode PPN35Ci

### Available Sizes

Hanger Width (W) (mm)	Hanger Depth (H) (mm)					
	170		220		300	
	Left	Right	Left	Right	Left	Right
39	45-L-39-170	45-R-39-170	45-L-39-220	45-R-39-220	45-L-39-300	45-R-39-300
46	45-L-46-170	45-R-46-170	45-L-46-220	45-R-46-220	45-L-46-300	45-R-46-300
50	45-L-50-170	45-R-50-170	45-L-50-220	45-R-50-220	45-L-50-300	45-R-50-300
61	45-L-61-170	45-R-61-170	45-L-61-220	45-R-61-220	45-L-61-300	45-R-61-300
65	45-L-65-170	45-R-65-170	45-L-65-220	45-R-65-220	45-L-65-300	45-R-65-300
72	45-L-72-170	45-R-72-170	45-L-72-220	45-R-72-220	45-L-72-300	45-R-72-300
75	45-L-75-170	45-R-75-170	45-L-75-220	45-R-75-220	45-L-75-300	45-R-75-300
92	45-L-92-170	45-R-92-170	45-L-92-220	45-R-92-220	45-L-92-300	45-R-92-300
100	45-L-100-170	45-R-100-170	45-L-100-220	45-R-100-220	45-L-100-300	45-R-100-300

See VS (pages 84 - 85) or VRC (pages 86 - 87) for skewers outwith 45°

Left Hand:

Right Hand:

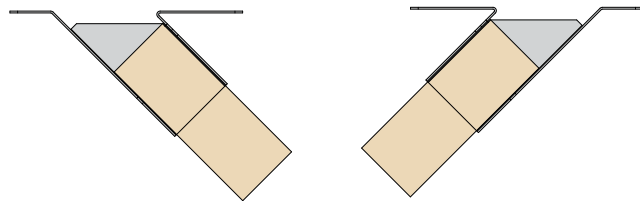

In Situ

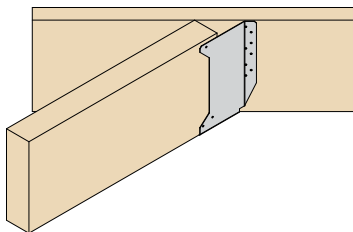

### Dimensions (mm)

170mm Deep

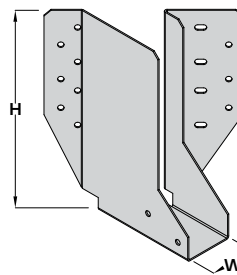

220-300mm Deep

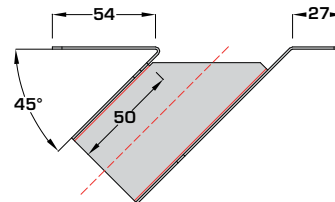
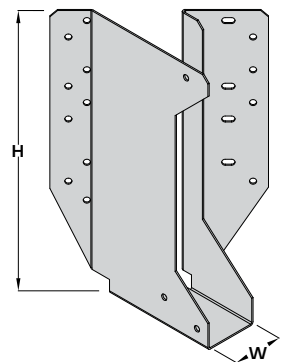

### Load Data

Hanger Depth (H) (mm)	Fixings (3.4 x 35mm)		Safe Working Loads (kN)				Characteristic Capacity (kN)			
			Uplift - Short Term	Long Term			Uplift	I-Joist Header With Backer Block (Solid/LVL Flange)	GL (Min GL28)	LVL
				I-Joist Header With Backer Block (Solid/LVL Flange)	GL (Min GL28)	LVL				
170	14	2	0.80	5.55	5.55	5.55	0.99	14.92	15.48	15.48
220	17	3	0.80	5.55	5.55	5.55	0.99	14.92	15.48	15.48
300	21	3	0.80	6.93	6.93	6.93	0.99	17.54	16.31	16.31

# UZ CLIP



## Noggin Support



The UZ Clip is a multifunctional connector for supporting solid timber and I-Joist noggins.

### Features & Benefits

- Suitable for supporting noggins in various applications
- Adjacent noggins can be aligned without clashing

### Material Specification

- Galvanised mild steel - Z275

### Fixings

Code	Description	Box Qty
547389	3.4 x 35mm Square Twist Nails - LOOSE	500
141185	3.4 x 35mm Square Twist Nails - COLLATED*	2,500

\*For use with Paslode PPN35C

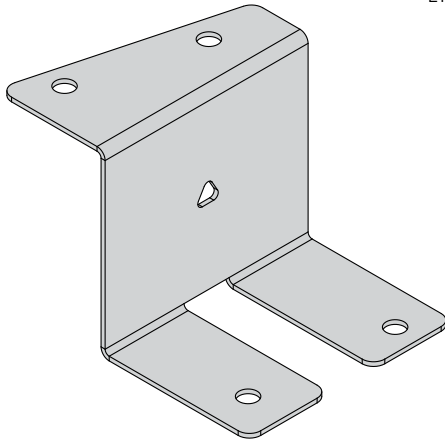

### Available Sizes

Product Code	Height (H) (mm)
UZ-35	35
UZ-38	38
UZ-45	45
UZ-47	47

### Dimensions (mm)

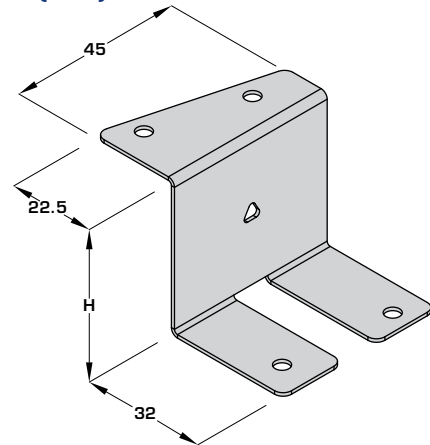

### In Situ

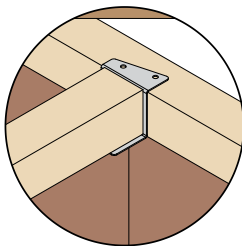
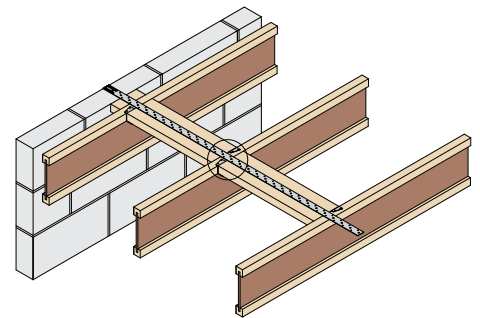
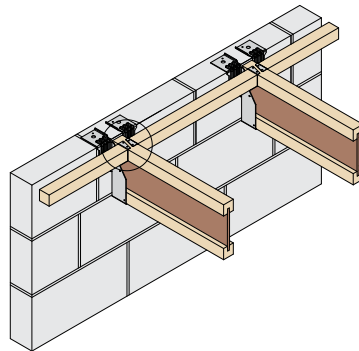
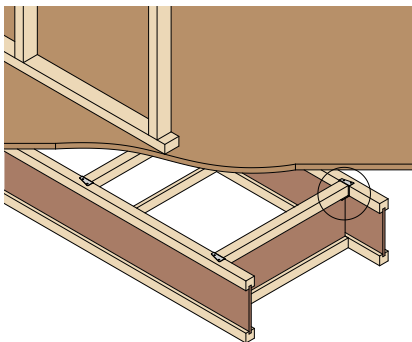

**Partition Noggins**

I-Joists / Open Webs Supporting Lightweight Partitions

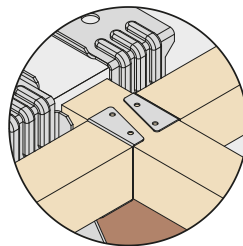

**Perimeter Noggins**

Support for decking and plasterboard

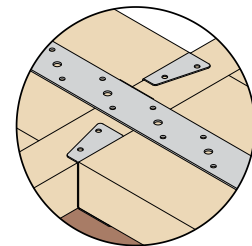

**Restraint Strap Noggins**

Fixing for perpendicular restraint straps

Refer to manufacturer's guidelines and NHBC Standards for noggin requirements

# UZ CLIP



## Noggin Support

### Load Data

Noggin Type	Fixings (3.4 x 35mm)		Safe Working Loads (kN) Short Term	Characteristic Capacity (kN)
	Header	Incoming		
Solid Timber	2	3	1.50	2.28
I-Joist	2	2	1.50	2.73

### Installation Instructions

#### STAGE 1

##### I-Joist Noggin

Fix UZ Clip to underside of I-Joist top flange with 2No 3.4 x 35mm square twist nails.

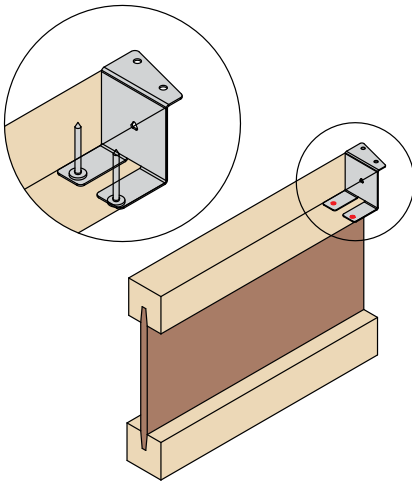

##### Solid Timber Noggin <50mm Wide

Fix UZ Clip to underside of noggin with 2No 3.4 x 35mm square twist nails. An additional 1No 3.4 x 35mm square twist nail is required in the timber end.

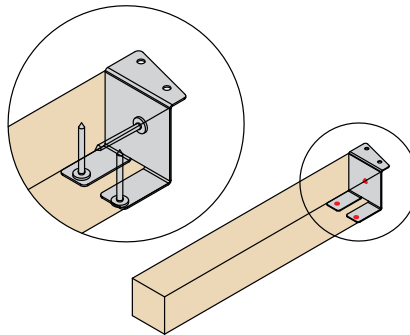

##### Solid Timber Noggin >50mm Wide

Fix UZ Clip to underside of noggin with 2No 3.4 x 35mm square twist nails. An additional 1No 3.4 x 35mm square twist nail is required in the timber end.

UZ Clips should be staggered.

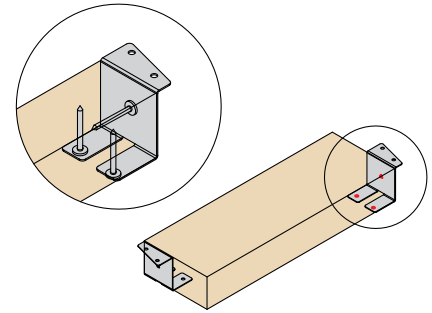

#### STAGE 2

##### I-Joist Noggin

Nail the UZ Clip to the top of the header joist with 2No 3.4 x 35mm square twist nails.

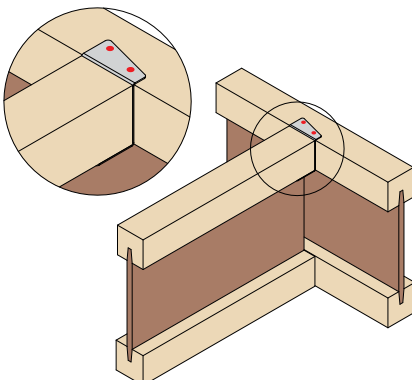

##### Solid Timber Noggin <50mm Wide

Nail the UZ Clip to the top of the header joist with 2No 3.4 x 35mm square twist nails.

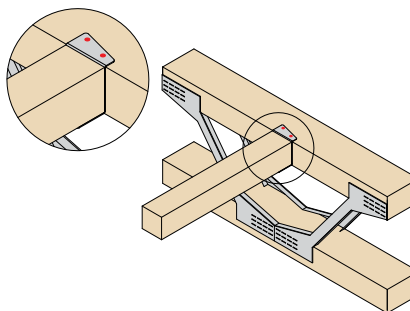

##### Solid Timber Noggin >50mm Wide

Nail the UZ Clip to the top of the header joist with 2No 3.4 x 35mm square twist nails.

A skew nail fixing will be required on the opposite side (approx. 75mm long).

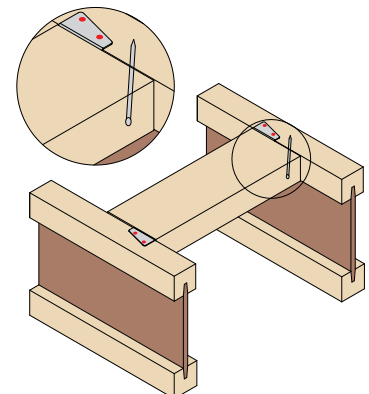

## Multiple I-Joist Connector

GB Patent: 2411216



The I-Clip is a single piece connector for joining multiple I-Joists together eliminating the need for filler blocks.

### Features & Benefits

- Quick and simple to install with flared end for ease of install
- Safely joins joists together allowing them to act as a single unit
- Visible connections to ensure compliance

### Material Specification

- Galvanised mild steel - Z275

### Fixings

Code	Description	Box Qty
547389	3.4 x 35mm Square Twist Nails - LOOSE	500
141185	3.4 x 35mm Square Twist Nails - COLLATED*	2,500

\*For use with Paslode PPN35Ci

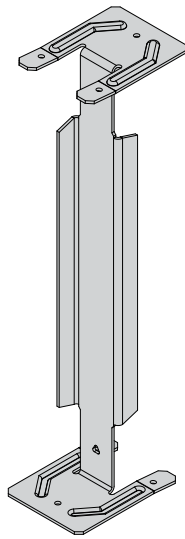

### In Situ

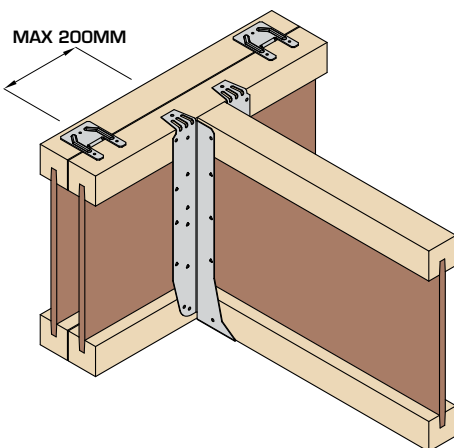

Installation either side of incoming point load to be maximum 200mm from joist edge.

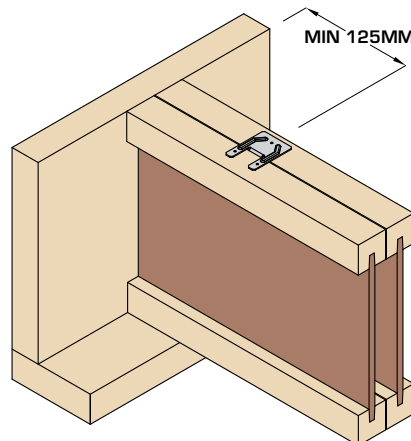

Installation on joist end to be minimum 125mm away from the end of the joist to allow adequate space for fixing.

### Dimensions (mm)

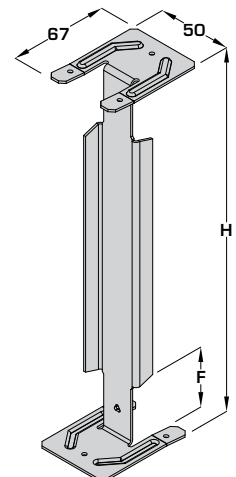

### Available Sizes

Joist Manufacturer	Flange Depth (F) (mm)	Joist Depth (H) (mm)										
		195	200	220	235	240/241	245	300/302	350	356	360	400
James Jones (JJI)	45	I-195-46	-	I-220-46	I-235-46	-	I-245-46	I-301-46	I-350-46	-	-	I-400-46
Metsawood (FJI)	36	-	-	I-220-38	-	I-241-38	-	I-301-38	-	-	-	-
Metsawood (FJI)	39	-	I-200-38	I-220-38	-	I-241-38	-	I-301-38	-	-	I-360-38	I-400-38
Steico (SJI)	39	-	I-200-38	I-220-38	-	I-241-38	-	I-301-38	-	-	I-360-38	I-400-38
Masonite (H, HB, HI, HL, HM)	47	REFER TO THE OW-CLIP										

Part is not width dependent

## Multiple I-Joist Connector

### Load Data (Maximum load on 2 ply headers \*)

#### Concentrated Point Load - 1 Pair

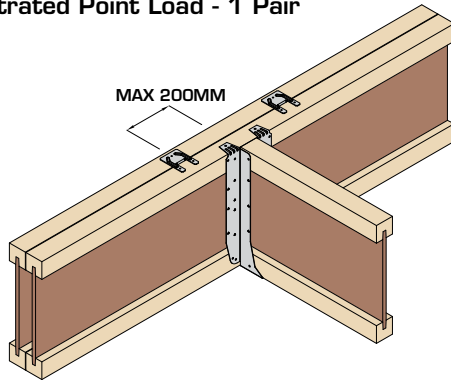

Fixings (3.4 x 35mm)		Safe Working Load (kN)		Characteristic Capacity (kN)	
Header (per anchor)	Supported (per anchor)	LVL Flange I-Joist	Solid Timber Flange I-Joist	LVL Flange I-Joist	Solid Timber Flange I-Joist
3	3	7.24	7.24	18.08	14.84

#### Concentrated Point Load - 2 Pairs

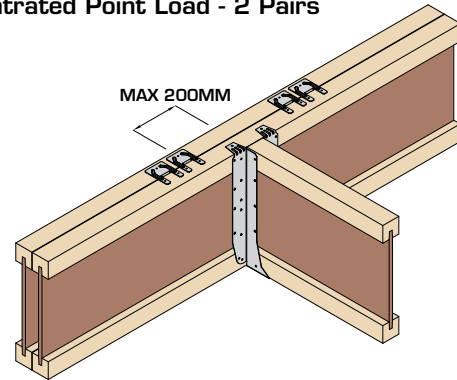

Fixings (3.4 x 35mm)		Safe Working Load (kN)		Characteristic Capacity (kN)	
Header (per anchor)	Supported (per anchor)	LVL Flange I-Joist	Solid Timber Flange I-Joist	LVL Flange I-Joist	Solid Timber Flange I-Joist
3	3	10.86	10.86	27.12	22.26

#### Regular Point Loads - 1 Pair

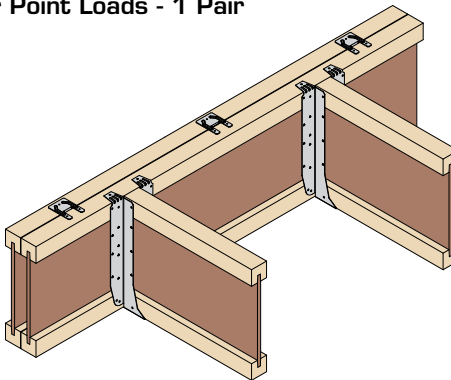

Fixings (3.4 x 35mm)		Safe Working Load (kN)		Characteristic Capacity (kN)	
Header (per anchor)	Supported (per anchor)	LVL Flange I-Joist	Solid Timber Flange I-Joist	LVL Flange I-Joist	Solid Timber Flange I-Joist
3	3	3.62	3.62	9.04	7.42

#### Regular Point Loads - 2 Pairs

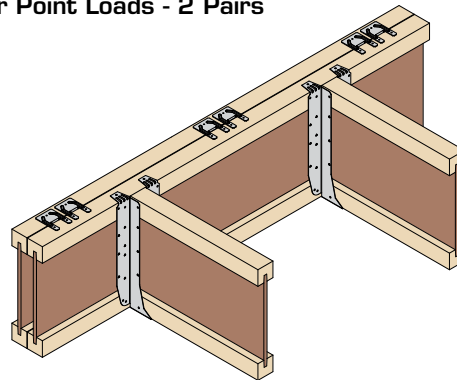

Fixings (3.4 x 35mm)		Safe Working Load (kN)		Characteristic Capacity (kN)	
Header (per anchor)	Supported (per anchor)	LVL Flange I-Joist	Solid Timber Flange I-Joist	LVL Flange I-Joist	Solid Timber Flange I-Joist
3	3	5.43	5.43	13.56	11.13

\*Please contact Technical Support for guidance on 3 ply connections.

### Installation Instructions

#### STAGE 1

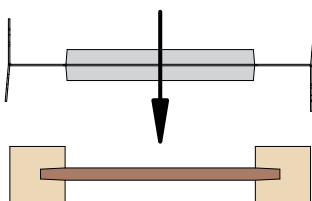

Lay I-Joist flat and mark location of I-Clips, press clips into position on top face of I-Joist.

#### STAGE 2

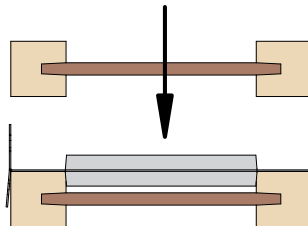

Position second ply of multiple joist on top of I-Clips and tap together with a hammer to ensure a tight fit.

#### STAGE 3

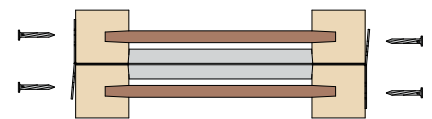

Fix I-Clips to top and bottom flanges of multiple I-Joist using 6No 3.4 x 35mm square twist nails ensuring that I-Joists are fitted tightly together.

# OW-CLIP



## Multiple Joist Connector

European Community Registered Design

The **OW-Clip** enables the connection of **2 ply joists** allowing them to act as a single unit.

### Features & Benefits

- One part can be used for all joist depths and widths
- Flared end for ease of install
- Visible connections to verify compliance

### Material Specification

- Galvanised mild steel - Z275

### Fixings

Code	Description	Box Qty
547389	3.4 x 35mm Square Twist Nails - LOOSE	500
141185	3.4 x 35mm Square Twist Nails - COLLATED*	2,500

\*For use with Paslode PPN35Ci

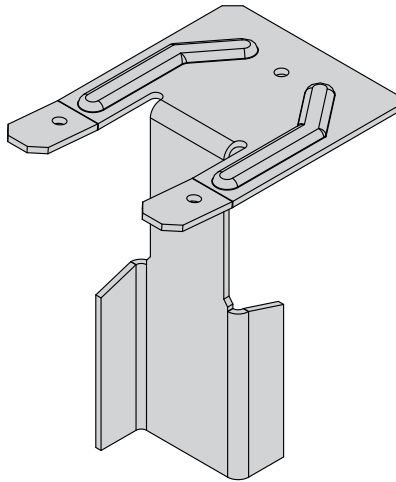

### Available Sizes

Product Code	Flange Depth (F) (mm)
OW-Clip-47	47

### In Situ

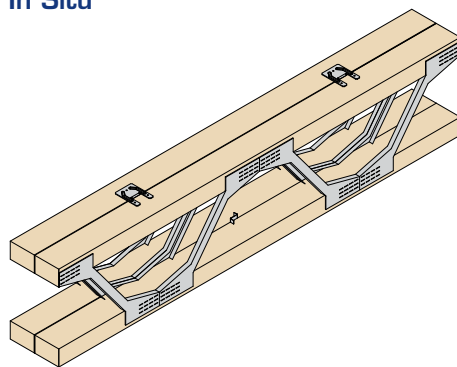

2 ply Open Web Connections

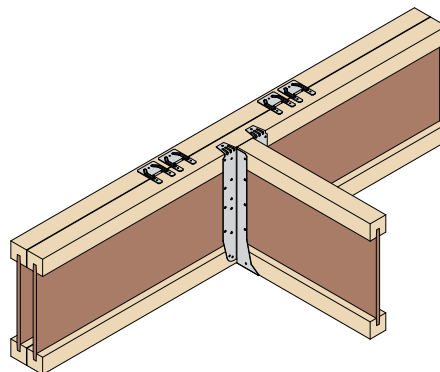

2 ply I-Joist Connections (Masonite I-Joists)

### Dimensions (mm)

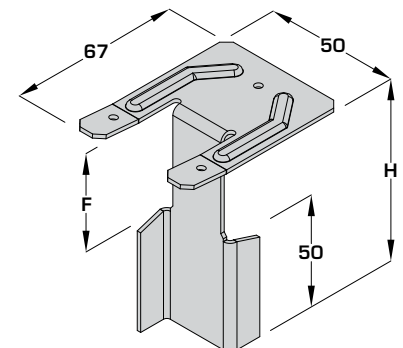

### Installation Instructions

#### STAGE 1

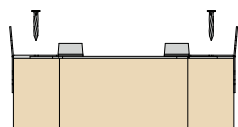

Lay joist flat and mark location of OW-Clips, press clips into position.

Fix clips to the face of the joist using 1No 3.4 x 35mm square twist nail per clip.

#### STAGE 2

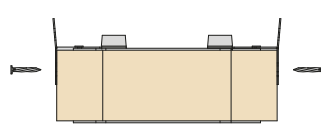

Fix clips to the top of the joist using 1No 3.4 x 35mm square twist nail per clip.

#### STAGE 3

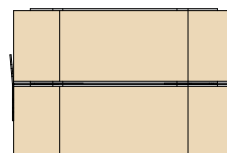

Position second ply of multiple joist on top of the OW-Clips and tap together with a hammer to ensure a tight fit.

#### STAGE 4

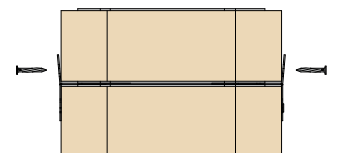

Fix OW-Clips to top and bottom chords of the multiple joist using 2No 3.4 x 35mm square twist nails per clip, ensuring that joists are fitted tightly together.

## Multiple Joist Connector

**Load Data** (Maximum load on 2 ply headers\*)

### Concentrated Point Load (Open Web Joists)

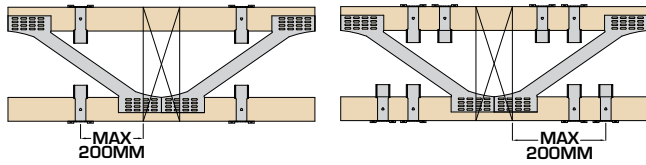

No of OW-Clips	Fixings (3.4 x 35mm)		Safe Working Load (kN)		Characteristic Capacity (kN)	
	Header (per anchor)	Supported (per anchor)	195 - 280mm Deep Joists	304 - 424mm Deep Joists	195 - 280mm Deep Joists	304 - 424mm Deep Joists
4	2	2	8.08	9.97	15.60	18.90
8	2	2	12.12	14.95	23.40	28.40

### Concentrated Point Load (Masonite I-Joists)

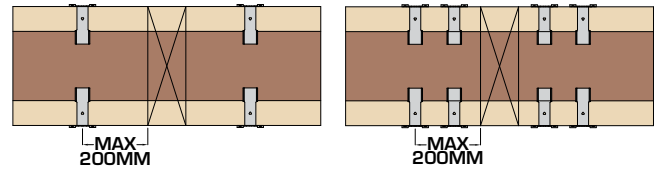

No of OW-Clips	Fixings (3.4 x 35mm)		Safe Working Load (kN)	Characteristic Capacity (kN)
	Header (per anchor)	Supported (per anchor)		
4	2	2	5.68	12.36
8	2	2	8.52	18.54

### Regular Point Loads / UDL (Open Web Joists)

(Incoming Joists @400C/C, Clips @600C/C)

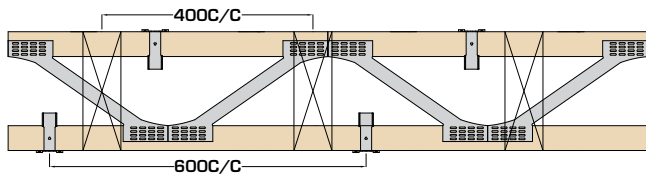

Fixings (3.4 x 35mm)		Safe Working Load (kN)				Characteristic Capacity (kN)			
Header (per anchor)	Supported (per anchor)	195 - 280mm Deep Joists		304 - 424mm Deep Joists		195 - 280mm Deep Joists		304 - 424mm Deep Joists	
		Max Point Load (kN)	Max UDL (kN/m)	Max Point Load (kN)	Max UDL (kN/m)	Max Point Load (kN)	Max UDL (kN/m)	Max Point Load (kN)	Max UDL (kN/m)
2	2	2.69	6.73	3.32	8.30	5.20	13.00	6.32	15.80

### Regular Point Loads / UDL (Masonite I-Joists)

(Incoming Joists @400C/C, Clips @600C/C)

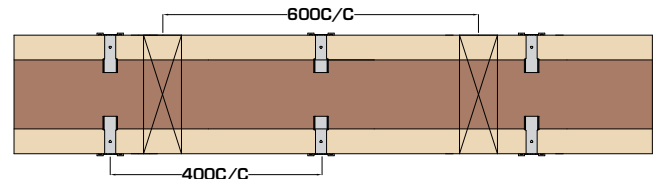

Fixings (3.4 x 35mm)		Safe Working Load (kN)		Characteristic Capacity (kN)	
Header (per anchor)	Supported (per anchor)	Max Point Load (kN)	Max UDL (kN)	Max Point Load (kN)	Max UDL (kN)
2	2	2.84	7.10	6.18	15.45

### Regular Point Loads / UDL (Open Web Joists)

(Incoming Joists @600C/C, Clips @600C/C)

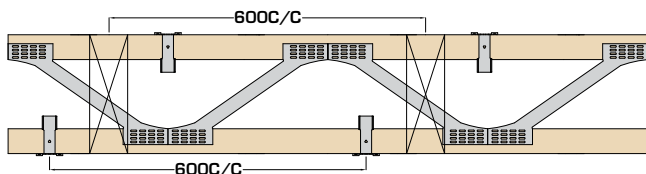

Fixings (3.4 x 35mm)		Safe Working Load (kN)				Characteristic Capacity (kN)			
Header (per anchor)	Supported (per anchor)	195 - 280mm Deep Joists		304 - 424mm Deep Joists		195 - 280mm Deep Joists		304 - 424mm Deep Joists	
		Max Point Load (kN)	Max UDL (kN/m)	Max Point Load (kN)	Max UDL (kN/m)	Max Point Load (kN)	Max UDL (kN/m)	Max Point Load (kN)	Max UDL (kN/m)
2	2	4.04	6.73	4.98	8.30	7.80	13.00	9.48	15.80

### Regular Point Loads / UDL (Masonite I-Joists)

(Incoming Joists @600C/C, Clips @600C/C)

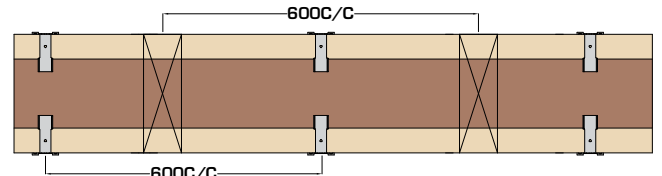

Fixings (3.4 x 35mm)		Safe Working Load (kN)		Characteristic Capacity (kN)	
Header (per anchor)	Supported (per anchor)	Max Point Load (kN)	Max UDL (kN)	Max Point Load (kN)	Max UDL (kN)
2	2	2.84	4.73	6.18	10.30

\*Paslode Structural Timber Screws to be used for 3 ply connections - see pages 96 - 100

## Multiple Connections



**CE**  
EN 4592

The Paslode Structural Screws are for use in various applications in timber frame where multiple members are required; typically trimmer joists, multiple floor joists, lintels and multiple girders.

### Features & Benefits

- Requires no pre-drilling
- Quick and easy to install
- Higher lateral load capacity than nails or screws of similar diameter
- Upgraded to improve withdrawal and shear load capabilities, increase speed of installation and to meet the design requirements of Eurocode 5
- Large diameter flanges under heads ensure very high resistance to pull-through loads



T30 head

6.5mm shank Ø, hex head

8mm shank Ø, hex head

### Available Sizes

Product Code	Reference	Length (L) (mm)	Box Qty*
551113	PSTS6.5x115	115	100

Product Code	Reference	Length (L) (mm)	Box Qty*
551124	PSTS6.5x35	35	100
551105	PSTS6.5x65	65	100
551106	PSTS6.5x100	100	100
551102	PSTS6.5x115	115	100
551107	PSTS6.5x150	150	100
551108	PSTS6.5x200	200	100
551109	PSTS6.5x250	250	100

Product Code	Reference	Length (L) (mm)	Box Qty*
551110	PSTS8x65	65	100
551103	PSTS8x85	85	100
551111	PSTS8x100	100	100
551112	PSTS8x135	135	100

\*A driver bit is supplied in every box

### Dimensions (mm)

#### Hex Head Screws

	PSTS6.5 (mm)		PSTS8.0 (mm)
	35 - 65	100 - 250	
d	6.50		8.00
d <sub>1</sub>	4.40		5.25
d <sup>2</sup>	4.80		5.85
d <sub>h</sub>	11.50		16.00
l <sub>g</sub>	30.00	50.00	52.00

#### Flat Head Screws

	PSTS6.5 (mm)
d	6.50
d <sub>1</sub>	4.40
d <sup>2</sup>	4.80
d <sub>h</sub>	16.00
l <sub>g</sub>	50.00

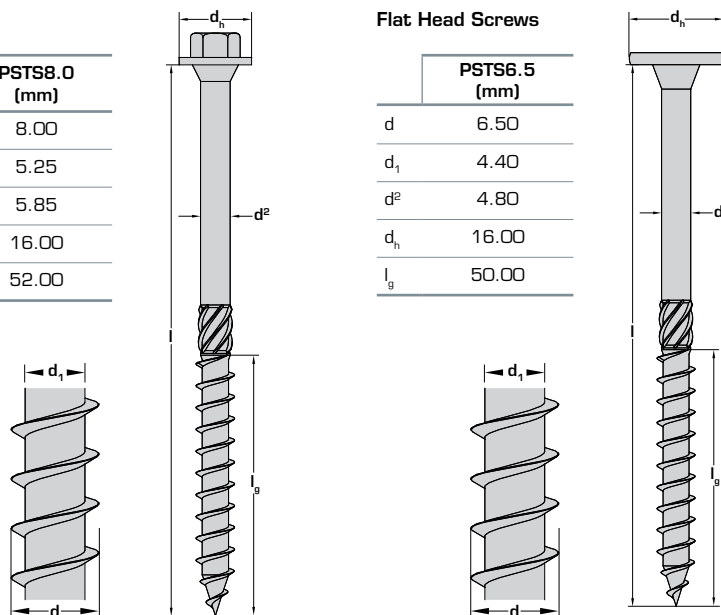



## Multiple Connections

### Characteristic Parameters For Calculation To Eurocode 5

	PSTS 6.5mm	PSTS 8.0mm
Characteristic yield moment (My,k)	14.74 kN/mm	18.60 kN/mm
Characteristic withdrawal parameter (f <sub>w</sub> ,k)	16.20 N/mm <sup>2</sup>	15.40 N/mm <sup>2</sup>
Characteristic head pull through parameter (f <sub>head</sub> ,k)	8.80 N/mm <sup>2</sup>	14.40 N/mm <sup>2</sup>

1. All data included is based on tests in accordance with EN14592.
2. Paslode Structural Tests are CE marked in accordance with EN14592 following testing at TRADA Technology. For applications outside the scope of those specified please contact our Technical Department.

## Connecting Multiple Open Web Joists With PSTS 6.5mm Ø

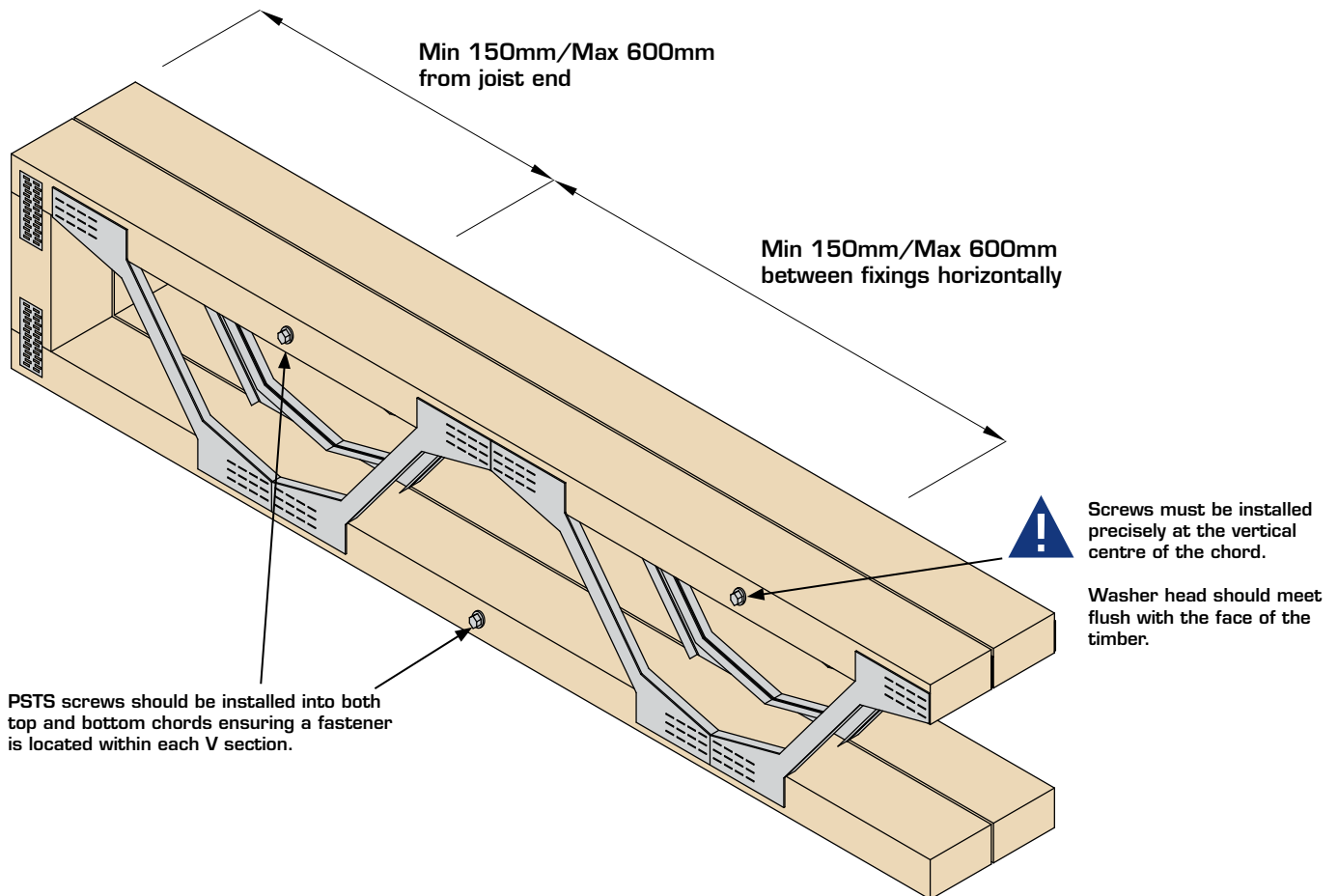

### PSTS 6.5mm - Lateral Load-carrying Capacities

Long-term permissible lateral load for a single Paslode STS 6.5mm for common 2-ply Open Web connections.

Open Web Connection - Fasteners to Top & Bottom Chords*	Length of Paslode STS 6.5mm	Long-Term Permissible Lateral Load-Carrying Capacity (kN) Per Fixing	Characteristic Capacity (kN) Per Fixing
2-ply 72mm wide Open Web Joists	115	0.75	2.28
2-ply 97mm wide Open Web Joists	150	0.75	2.28
2-ply 122mm wide Open Web Joists	200	0.60	1.65
2-ply 147mm wide Open Web Joists	250	0.60	1.65

\*This table assumes top and bottom chords of TR26 timber.

## Multiple Connections

### Connecting Multiple Glulam & Solid Timber Members With PSTS 8mm Ø

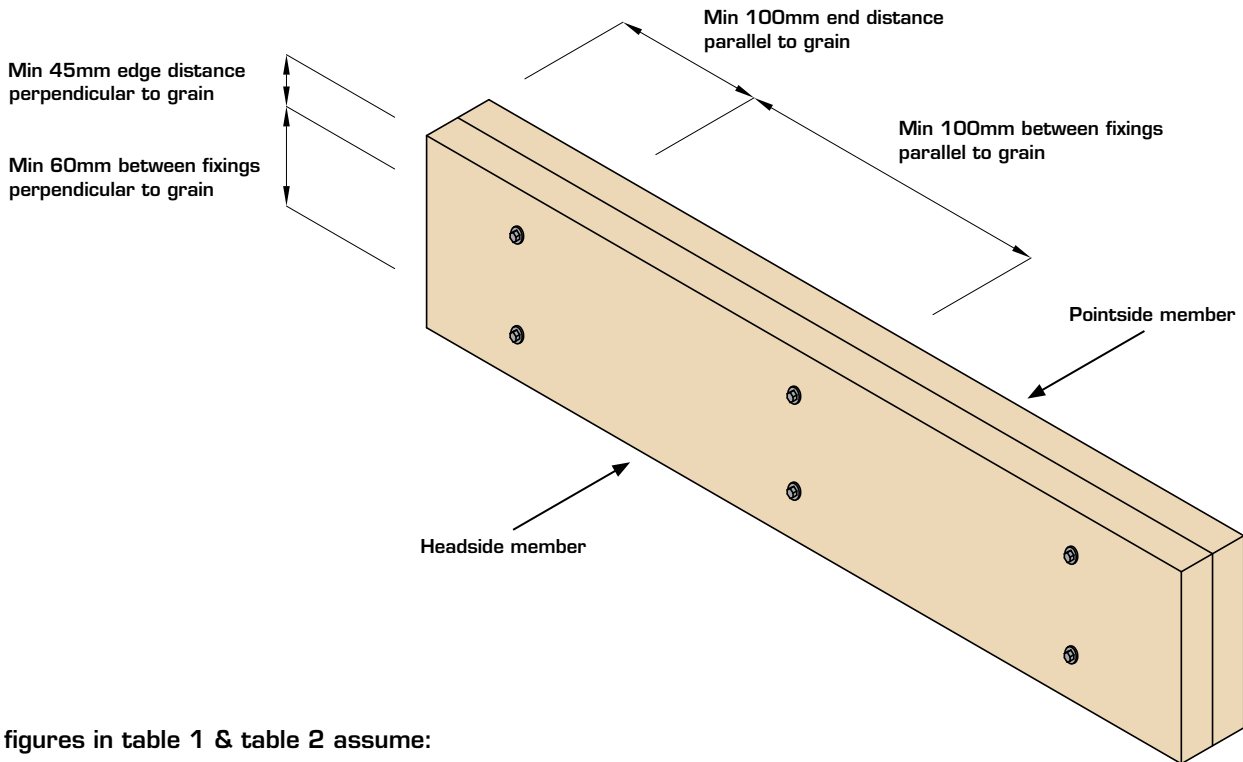

The figures in table 1 & table 2 assume:

1. The load may be acting parallel or perpendicular to the grain.
2. Minimum pointside penetration of 25mm for Glulam members (Table 1).
3. Minimum pointside penetration of 30mm for solid timber members (Table 2).

#### PSTS 8.0mm - Lateral Load-carrying Capacities - Glulam (Table 1)

Long-term permissible lateral load for a single Paslode STS 8.0mm for common combinations of 2 member joints in Glulam (GL28).

Thickness of Headside Member (mm)	Thickness of Pointside Member (mm)	Length of Paslode STS 8.0mm	Long-Term Permissible Lateral Load-Carrying Capacity (kN) Per Fixing Safe Working Load	Long-Term Permissible Lateral Load-Carrying Capacity (kN) Per Fixing Characteristic Capacity
38	38	65	0.90	2.18
45	45	85	1.21	2.92
38	75	100	1.24	2.99
75	75	135	1.46	3.51

#### PSTS 8.0mm - Lateral Load-carrying Capacities - Solid Timber (Table 2)

Long-term permissible lateral load for a single Paslode STS 8.0mm for common combinations of 2 member joints in solid timber (TR26).

Thickness of Headside Member (mm)	Thickness of Pointside Member (mm)	Length of Paslode STS 8.0mm	Long-Term Permissible Lateral Load-Carrying Capacity (kN) Per Fixing Safe Working Load	Long-Term Permissible Lateral Load-Carrying Capacity (kN) Per Fixing Characteristic Capacity
35	35	65	0.86	2.07
45	45	85	1.13	2.72
47	47	85	1.12	2.69
75	75	135	1.38	3.32

## Multiple Connections

### PSTS Procedure For Designing Connections of Multiple Girder Roof Trusses

#### Maximum Return Spans of Incoming Trusses For A Range of PSTS 8.0mm Spacings

**Table 1 - Maximum Return Spans of Trusses Spanning Onto 2-Ply Girder Trusses**

Size of Bottom Chord Members of Girder Truss (mm)	Length of Paslode STS 8.0mm	Maximum Return Spans (m) of Incoming Trusses for Paslode STS 8.0mm Spacings (S) of:					
		100mm	150mm	200mm	300mm	400mm	600mm
35 x 72, 35 x 84	65mm	N/A	7.1	5.1	3.2	2.2	N/A
35 x 97	65mm	N/A	9.1	6.6	4.2	2.9	1.7
35 x 122, 35 x 147, 35 x 172	65mm	11.0	9.1	6.6	4.2	2.9	1.7
47 x 72, 47 x 84	85mm	N/A	11.6	8.5	5.4	3.9	2.3
47 x 97	85mm	N/A	14.7	10.8	7.0	5.0	3.1
47 x 122, 47 x 147, 47 x 172, 47 x 197, 47 x 220	85mm	15.0	14.7	10.8	7.0	5.0	3.1

**Table 2 - Maximum Return Spans of Trusses Spanning Onto 3-Ply Girder Trusses**

Size of Bottom Chord Members of Girder Truss (mm)	Length of Paslode STS 8.0mm	Maximum Return Spans (m) of Incoming Trusses for Paslode STS 8.0mm Spacings (S) of:					
		100mm	150mm	200mm	300mm	400mm	600mm
35 x 72, 35 x 84	100mm	N/A	5.1	3.7	2.2	1.5	N/A
35 x 97	100mm	N/A	6.1	4.8	2.9	2.0	N/A
35 x 122, 35 x 147, 35 x 172	100mm	10.3	6.6	4.8	2.9	2.0	N/A
47 x 72, 47 x 84	135mm	N/A	18.5	6.2	3.9	2.7	1.6
47 x 97	135mm	N/A	10.8	7.9	5.0	3.6	2.1
47 x 122, 47 x 147, 47 x 172, 47 x 197, 47 x 220	135mm	15.0	10.8	7.9	5.0	3.6	2.1

#### Notes

- The return spans of tables 1 & 2 presume that the bottom chords of the girder trusses are strength class TR26 timber
- The return spans of tables 1 & 2 presume that the Paslode STS 8.0mm are inserted into the girder trusses in accordance with the fastener layouts of Figures 1-4
- For 44mm thick timbers the tabulated return spans given for 47mm thick timbers may be used
- Where plain concrete tiles (maximum top chord deal load of 0.88kN/m<sup>2</sup> on slope) are used instead of interlocking concrete tiles, then tabulated return spans should be multiplied by 0.9

#### Design Assumptions

The connection details given are applicable to trusses with pitches between 15° and 45° and supporting the following loadings:

Top Chord Dead Load (kN/m <sup>2</sup> on slope)		0.685
Top Chord Imposed (snow) Load (kN/m <sup>2</sup> plan)	For Pitches ≤30°	0.75
	For Pitches >30°	0.75 [(960 - pitch) / 30]
Bottom Chord Dead Load (kN/m <sup>2</sup> )		0.25
Bottom Chord Imposed (storage) Load (kN/m <sup>2</sup> ) - Water Tank Loads as BS5268-3		0.25

## Multiple Connections

### Layout of Paslode STS 8.0mm In Bottom Chords

Figure 1 - Bottom Chords Depths of 72mm, 84mm or 97mm

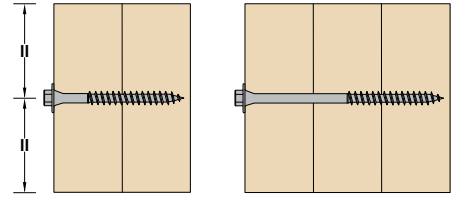
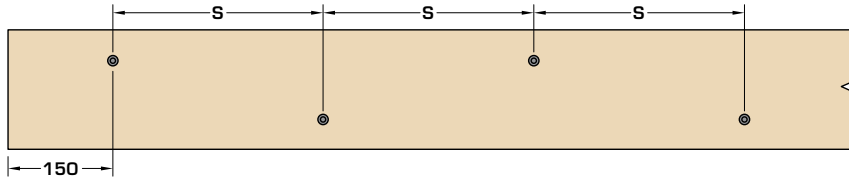
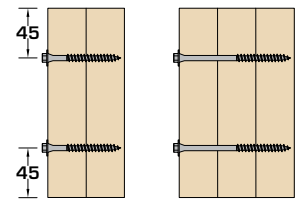
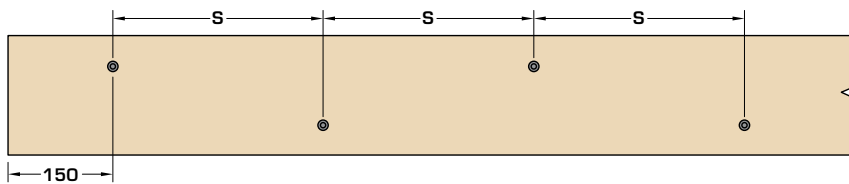

Figure 2 - Bottom Chords Depths of 122mm, 147mm, 172mm, 197mm or 222mm



### Layout of Paslode STS 8.0mm In Webs & Top Chords

Figure 3 - Top Chords/Webs of Depths 72mm, 84mm or 97mm

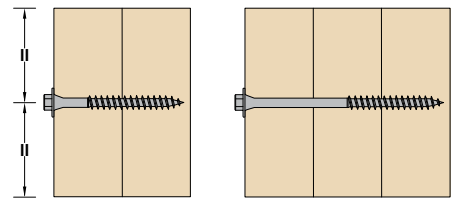
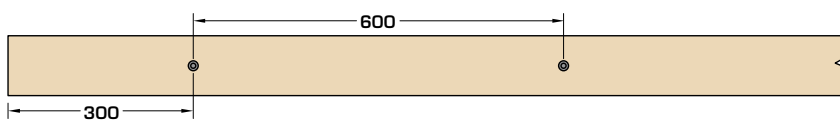
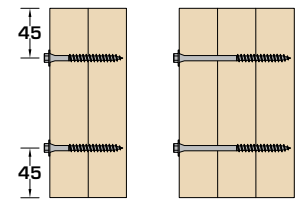
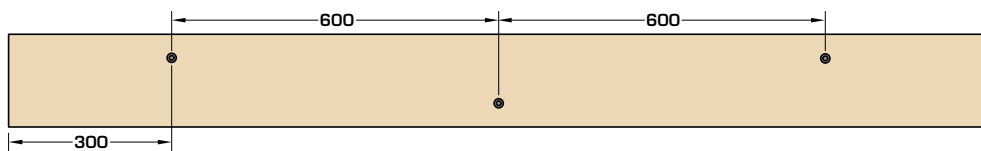

Figure 4 - Top Chords/Webs of Depths 122mm, 147mm, 172mm, 197mm or 222mm



**!** FASTENERS CAN BE INSTALLED FROM ONE SIDE OF GIRDER TRUSS  
 Except when connecting 4-ply, which must be connected from both sides.  
 For further information please contact Technical Support.

### Installation Instructions

#### STAGE 1

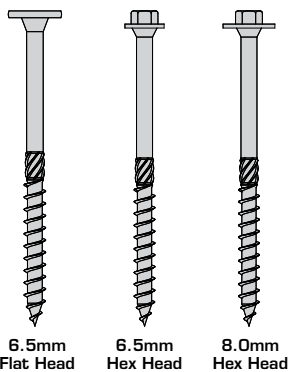

Select the correct fastener type and size.

#### STAGE 2

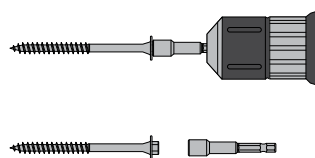

Install using an impact driver.  
 (One hex driver bit is included in every box)

#### STAGE 3

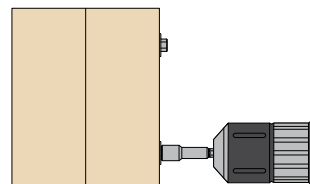

Bring the underside of the washer head flush with the timber surface.



**Do not countersink or overdrive.**

#### STAGE 4

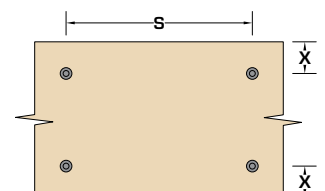

Always maintain the required minimum edge distance and spacing.



**These values vary - please refer to relevant details.**

## Service Hole I-Joist

GB Patent: 2496059B

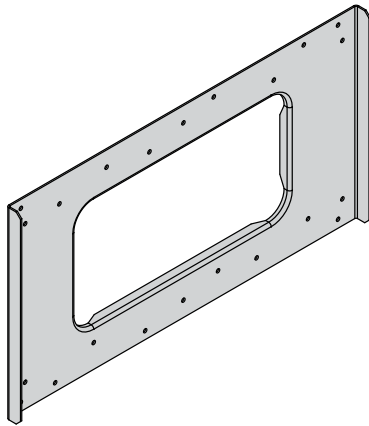

### Available Sizes

Product Code	Product Description	I-Joist Depth (mm)	Dimensions (mm)	
			H	F
548377	SHI-220-1	220	215	127
548380	SHI-240-1	240/245	240	152
548381	SHI-300-1	300	300	207

Suitable for use with JJI (45mm flange), SJI (45mm flange), MJI (45mm flange) and FJI (39mm flange). Contact Technical Support for use with multiple ply members.



The use of SHI plates must be assessed for suitability by a qualified design professional.

Please contact your system provider for further information on assessing joist suitability.

### In Situ

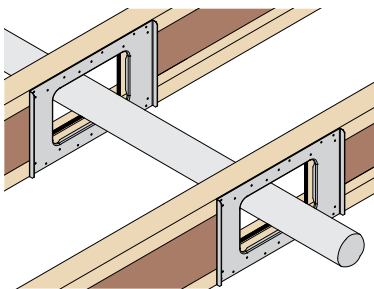
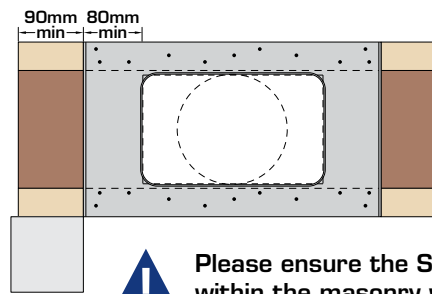

Plate required each side of aperture.



Position SHI plate at least 90mm from joist end to ensure it does not clash with masonry hanger or end seal (suitable for use with Hi-Vis Gripper).



Please ensure the SHI plates are not installed within the masonry wall/mortar

### Installation Instructions

#### STAGE 1

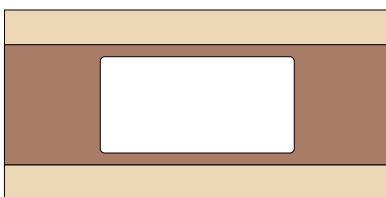

Using the SHI plate as a template, drill 4No holes and cut inner aperture to suit.

#### STAGE 2

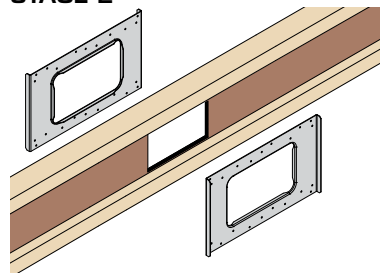

Place 1No SHI plate either side of the aperture.

#### STAGE 3

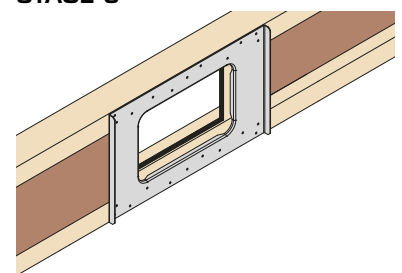

Fix the SHI plates to the I-Joist with 22No 3.4 x 35mm square twist nails per plate.

The SHI plate is a reinforcement plate that allows large apertures to be cut into an I-Joist web to accommodate service runs.

### Features & Benefits

- Allows larger apertures to be cut into I-Joist web whilst providing additional strength and stiffness to the I-Joist
- Potential remedial solution for damaged webs (Contact your system provider for further information)

### Material Specification

- Galvanised mild steel - Z275

### Fixings

Code	Description	Box Qty
547389	3.4 x 35mm Square Twist Nails - LOOSE	500
141185	3.4 x 35mm Square Twist Nails - COLLATED*	2,500

\*For use with Paslode PPN35Ci

### Dimensions (mm)

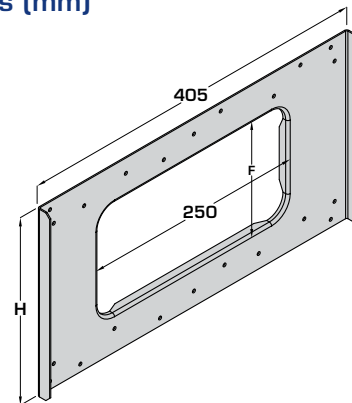

# Solid Timber/Roof Truss Overview

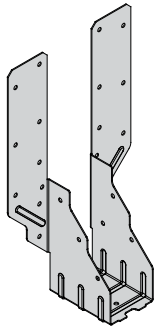

**TS**  
Page 106

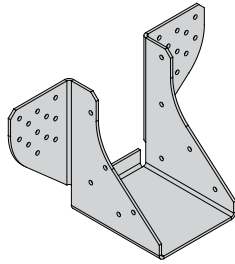

**HMH**  
Page 107

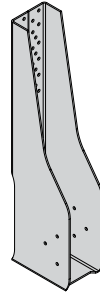

**HGG**  
Page 108

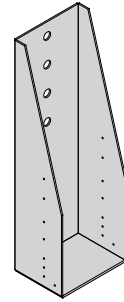

**VHGG**  
Page 109

**STANDARD TRUSS**

**HIGH LOAD TRUSS**

**VERY HIGH LOAD TRUSS**

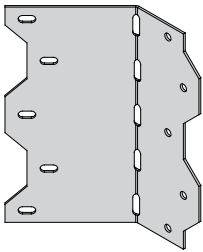

**SA-45**  
Page 116

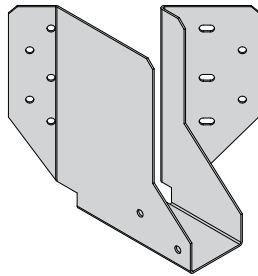

**45L/R**  
Page 117

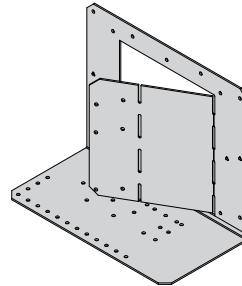

**VS**  
Pages 118 - 119

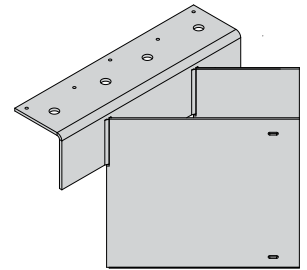

**FTHIS**  
Page 114

**SKEWED**

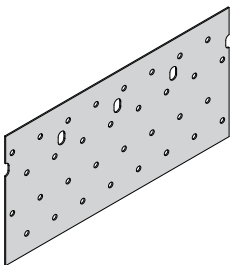

**NP**  
Page 120

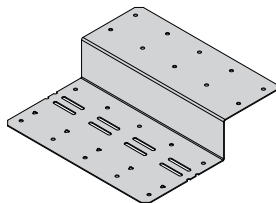

**SB**  
Page 121

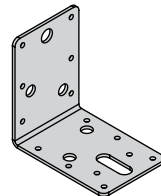

**LAB-180**  
Page 115

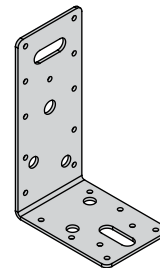

**LAB-240**  
Page 115

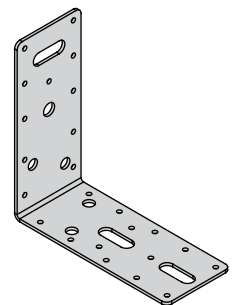

**LAB-300**  
Page 115

**ANCILLARY**

**ANGLE BRACKETS**

# Solid Timber/Roof Truss Overview

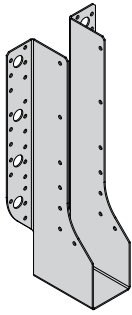

**MHE**  
Pages 112 - 113

**FACE FIX**

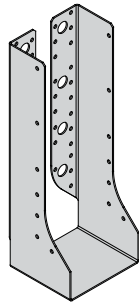

**MHI**  
Pages 112 - 113

**INTERNAL FLANGE**

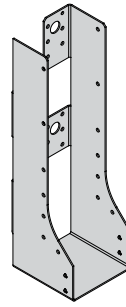

**MHIC**  
Pages 112 - 113

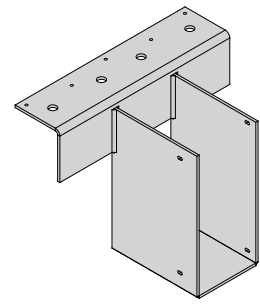

**FTHI**  
Page 114

**HIGH LOAD TRUSS**

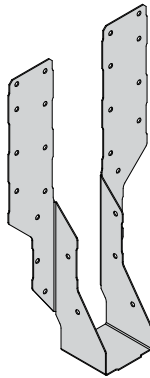

**KH**  
Page 110

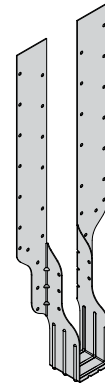

**KHL**  
Page 111

**KWIKI**

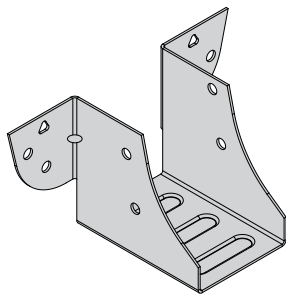

**KM**  
Page 104

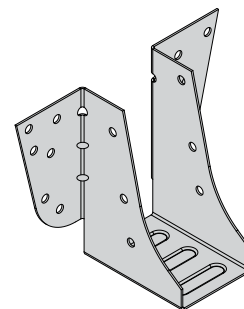

**TM**  
Page 105

**COMPACT SOLUTIONS**

Solid Timber /  
Roof Truss

## Mini Hanger

NEW & IMPROVED FOR 2017

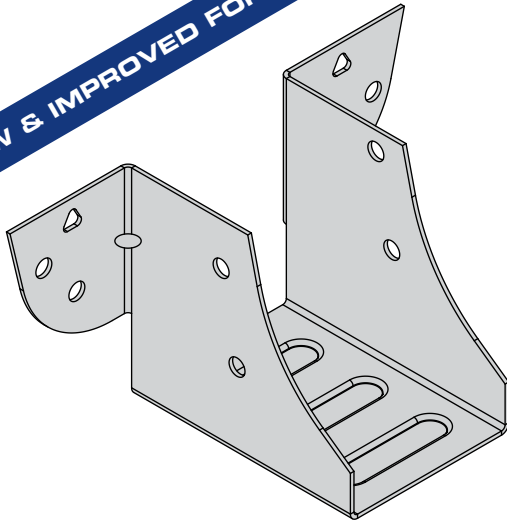

The KM hanger is used to support joists and trusses where a compact economical connector is required.

### Features & Benefits

- New and improved design achieves higher load carrying capacities
- Additional side fixings allow for increased uplift capacity
- Optional triangular holes for increased performance on solid headers
- Rear location tab to assist with installation

### Material Specification

- Galvanised mild steel - Z275

### Fixings

Code	Description	Box Qty
547389	3.4 x 35mm Square Twist Nails - LOOSE	500
141185	3.4 x 35mm Square Twist Nails - COLLATED*	2,500

\*For use with Paslode PPN35Ci

### Available Sizes

Product Code	Hanger Width (W) (mm)	Hanger Depth (H) (mm)
KM-38	38	49
KM-44	44	46
KM-50	50	43

### Dimensions (mm)

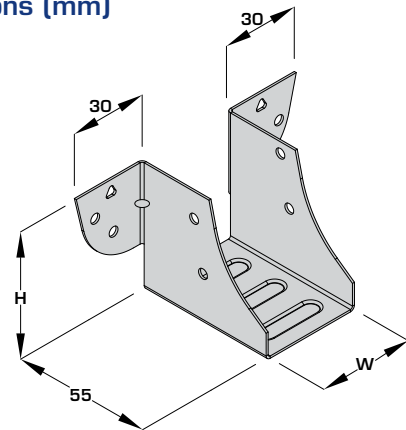

### In Situ

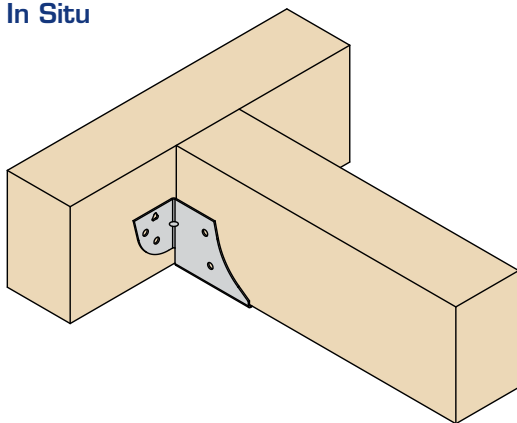

### Load Data

Product Code	Fixings (3.4 x 35mm)		Safe Working Loads (kN)				Characteristic Capacity (kN)**	
	Header	Incoming	Uplift - Short Term	Solid Timber Header (Min C16)			Uplift	Solid Timber Header (Min C16)
				Long Term	Medium Term	Short Term		
KM-38, KM-44, KM-50	6	4	1.00	2.56	2.92	3.06	2.20	3.41

\*\*Values obtained from tests carried out by ITW Construction Products and calculated in accordance with ETAG 015.

Values apply to new design only. Please contact Technical Support for further information if required.



## Midi Shoe

NEW & IMPROVED FOR 2017

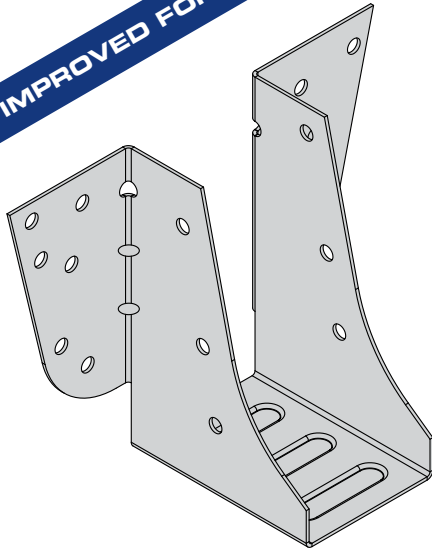

The TM hanger is used to support trusses in lower load applications from bottom chord depths 97mm and above.

### Features & Benefits

- New and improved design achieves higher load carrying capacities
- Additional side fixings allow for increased uplift capacity
- Rear location tab to assist with installation
- Economical solution for lower load applications

### Material Specification

- Galvanised mild steel - Z275

### Fixings

Code	Description	Box Qty
547389	3.4 x 35mm Square Twist Nails - LOOSE	500
141185	3.4 x 35mm Square Twist Nails - COLLATED*	2,500

\*For use with Paslode PPN35Ci

### Available Sizes

Product Code	Hanger Width (W) (mm)	Hanger Depth (H) (mm)
TM-38	38	81
TM-44	44	78
TM-50	50	75

### Dimensions (mm)

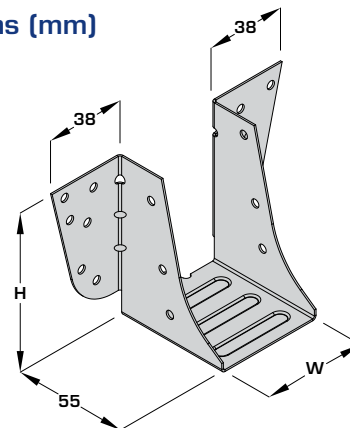

### In Situ

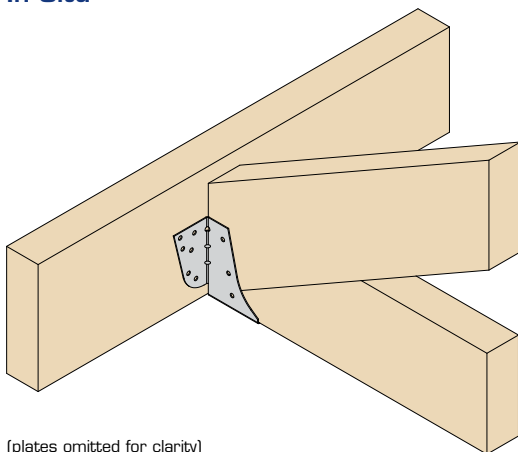

(plates omitted for clarity)

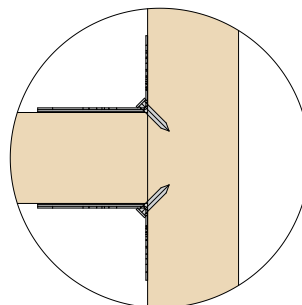

New 45 degree skew nailing

(other nails omitted for clarity)

### Load Data

Product Code	Fixings (3.4 x 35mm)			Safe Working Loads (kN)				Characteristic Capacity (kN)**	
	Header	Skew Nails	Incoming	Uplift - Short Term	Solid Timber Header (Min C16)			Uplift	Solid Timber Header (Min C16)
					Long Term	Medium Term	Short Term		
TM-38, TM-44, TM-50	12	2	6	2.00	5.40	5.40	5.50	3.32	9.54

\*\*Values obtained from tests carried out by ITW Construction Products and calculated in accordance with ETAG 015.

Values apply to new design only. Please contact Technical Support for further information if required.

## Truss Shoe

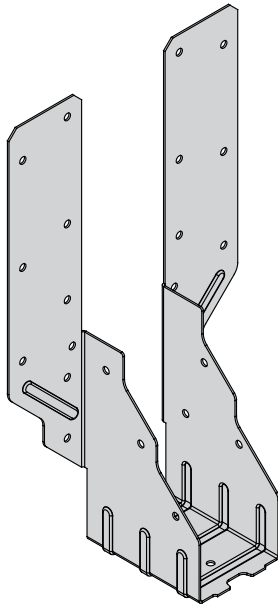

The TS hanger is designed to support trussed rafters from primary girders.

### Features & Benefits

- 4 sizes available to suit standard single or double trussed rafters
- Allows design loading to be effectively transferred without local over stressing
- The high performance nail configuration minimises any direct deflection or rotation caused by the incoming truss not abutting the primary girder

### Material Specification

- Galvanised mild steel - Z275

### Fixings

Code	Description	Box Qty
547389	3.4 x 35mm Square Twist Nails - LOOSE	500
141185	3.4 x 35mm Square Twist Nails - COLLATED*	2,500

\*For use with Paslode PPN35C

### Available Sizes

Product Code	Minimum Header Depth* (mm)	Dimensions (mm)		
		(W)	(H)	(F)
TS-38	120	38	256	120
TS-50	120	50	250	114
TS-75	120	75	237	101
TS-100	89	100	225	89

\*\*When timber depth is shallower than 'F' dimension a timber packer is required.

Nail packer to truss with 3No fixings into front ply, 3No fixings into rear ply using Paslode annular ring shank 2.8 x 63mm.

### Dimensions (mm)

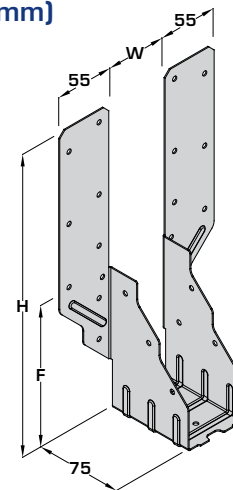

### In Situ

#### Standard Installation:

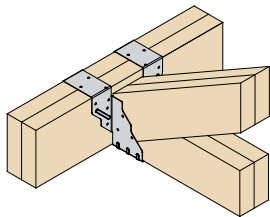

Timber depth greater than 'F' dimension

#### Face Fix Installation:

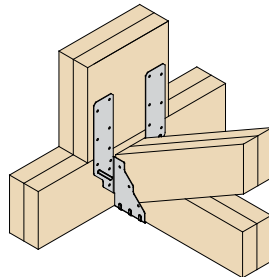

#### Single Leg Face Fix Installation:

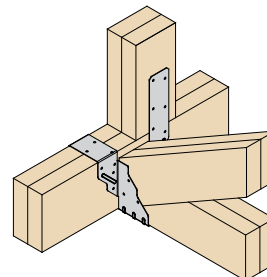

#### With Packer Installation\*\*:

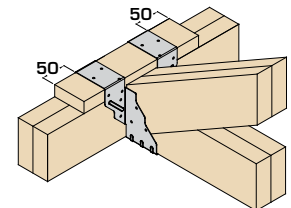

### Load Data

Product Code	Fixings (3.4 x 35mm)		Safe Working Loads (kN)				Characteristic Capacity (kN)	
	Header	Incoming	Uplift - Short Term	Solid Timber Header (Min C16)			Uplift	Solid Timber Header (Min C20)
				Long Term	Medium Term	Short Term		
TS-38, TS-50, TS-75, TS-100	18	6	2.00	8.20	9.37	9.64	5.62	15.52

## Heavy Multi Hanger



The HMH hanger is designed to support multiple trusses connecting to girders in medium to high load situations.

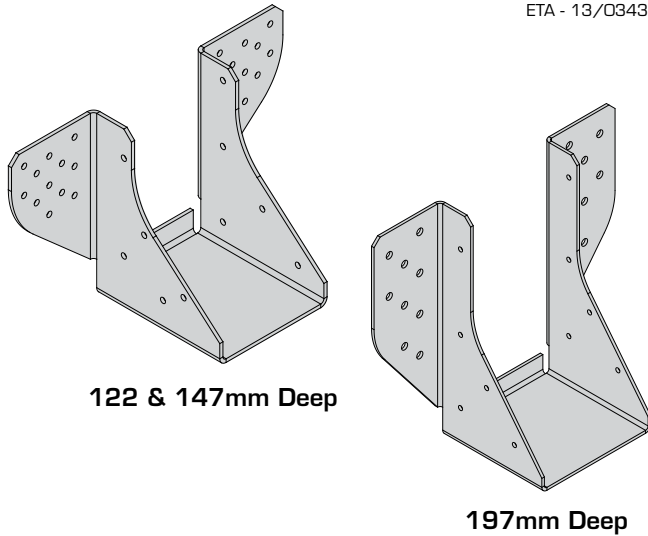

122 & 147mm Deep

197mm Deep

### Features & Benefits

- High load capacity can be achieved with fixings into the bottom chord only
- A variety of fixing details allows increased performance

### Material Specification

- Galvanised mild steel - Z275

### Fixings

All fixings supplied with hanger

Depth	Description
122mm	3.35 x 50mm Annular Ring Shank Nails
147mm	3.35 x 50mm Annular Ring Shank Nails
197mm	Paslode PSTS 6.5 x 65mm

### Available Sizes

Hanger Width (W) (mm)	Hanger Depth (mm)		
	122	147	197
80	HMH-80-122	HMH-80-147	HMH-80-197
102	HMH-102-122	HMH-102-147	HMH-102-197
118	-	HMH-118-147	HMH-118-197
153	-	HMH-153-147	HMH-153-197
198	-	-	HMH-198-197

### Dimensions (mm)

122 & 147mm deep - 4mm Ø holes

197mm deep - 6mm Ø holes

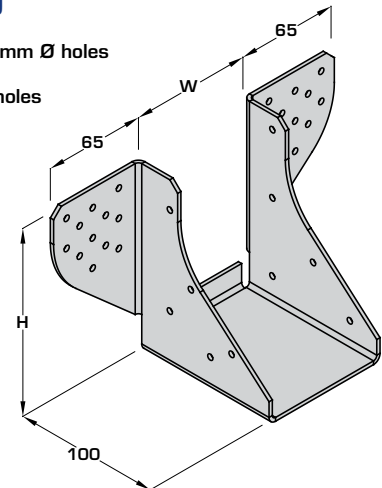

### In Situ

Bottom Chord Fixing:

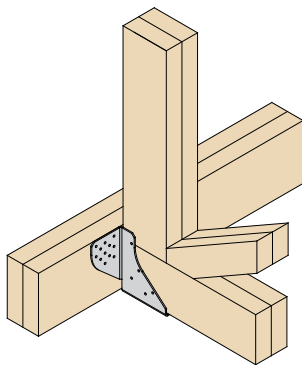

Ridge Connections:

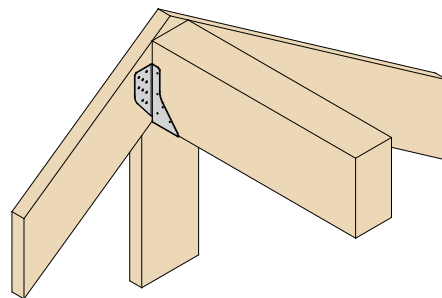

Please discuss suitability with Technical Support

### Load Data

Hanger Depth (mm)	Dimensions (mm)	Fixings		Safe Working Loads (kN)			Characteristic Capacity (kN)	
		Header (3.35 x 50mm)	Incoming (3.4 x 35mm)	Uplift - Short Term	Solid Timber Header (Min TR26)		Uplift	Solid Timber Header (Min TR26)
					Long Term	Medium Term		
122	122	24	10	4.94	12.10	13.83	9.83	26.08
147	145	34	10	4.94	13.88	15.86	9.83	32.45
197	195	Header (PSTS 6.5 x 65mm)	Incoming (3.4 x 35mm)	4.94	19.39	22.16	9.83	39.49

Incoming trusses must be connected together to act as a single unit.

## Heavy Girder To Girder

NEW & IMPROVED FOR 2017

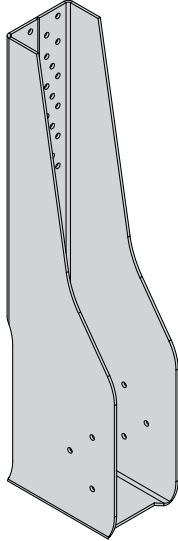

The HGG hanger is designed to support multiple ply girder trusses from a vertical web in high load situations.

### Features & Benefits

- New and improved design using PSTS screws simplifies the installation
- Allows fixings into vertical web only
- Additional side fixings allows for greater uplift capacity

### Material Specification

- Galvanised mild steel - Z275

### Fixings

40No Paslode PSTS 6.5 x 65mm supplied with hanger

### Dimensions (mm)

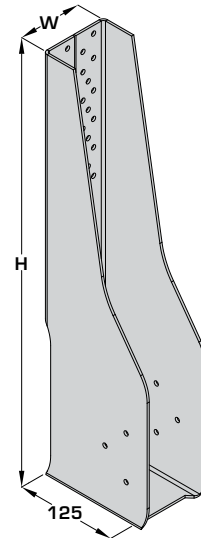

### Available Sizes

Product Code	Incoming Truss Width	Minimum Header Width (mm)	Hanger Width (W) (mm)	Hanger Depth (H) (mm)
HGG-80	2No 35	97	80	519
HGG-102	2No 47	122	102	508
HGG-153	3No 47	147	153	542
HGG-200	4No 47	197	200	519

Incoming and header trusses must be connected together to act as a single unit

### In Situ

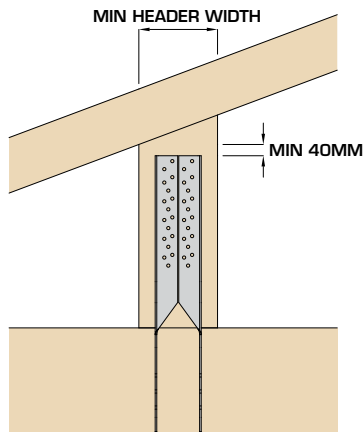

Minimum edge distances must be met to achieve full capacity.

### Load Data

Product Code	Fixings		Safe Working Loads (kN)			Characteristic Capacity (kN)	
	PSTS 6.5 x 65mm		Uplift - Short Term	Solid Timber Header (Min TR26)		Uplift	Solid Timber Header (Min TR26)
	Header	Incoming		Long Term	Medium Term		
HGG-80, HGG-102, HGG-153, HGG-200	34	6	6.00*	26.70*	30.50*	11.40*	64.60

\*Minimum 122mm deep bottom chord required to achieve the full uplift capacity

## Very Heavy Girder To Girder

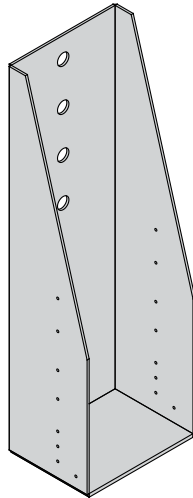

The VHGG hanger is designed to support multiple ply girder trusses from a vertical web in very high load situations.

### Features & Benefits

- Fixings into vertical web only therefore no requirement for increased bottom chord depths
- Additional side fixings allows for greater uplift capacity

### Material Specification

- Zinc undercoated

### Fixings

- 4No M20 Bolts - 180mm long fully threaded (inc nut, round washer, form G washer) supplied with part\*\*

### Available Sizes

Product Code	Incoming Truss Width	Hanger Width (W) (mm)
VHGG-80	2No 35 <sup>(2)</sup>	80
VHGG-102	2No 47 <sup>(2)</sup>	102
VHGG-118	3No 35 <sup>(3)</sup>	118
VHGG-153	3No 47 <sup>(3)</sup>	153
VHGG-200	4No 47 <sup>(4)</sup>	200

<sup>(2)(3)(4)</sup>Trusses must be connected together to act as a single unit

### In Situ

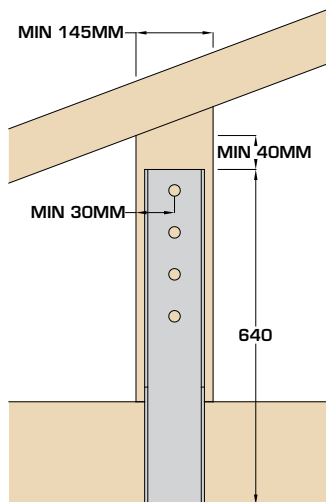

Minimum edge distances must be met to achieve full capacity.

For reduced bolting please contact Technical Support.

(Plates omitted for clarity)

### Load Data

Product Code	Fixings		Safe Working Loads (kN)			Characteristic Capacity (kN)		
	Header Bolts M20	Incoming Nails (3.4 x 35mm)	Uplift - Short Term	Solid Timber Header (Min TR26)		Uplift	Solid Timber Header (Min TR26)	
				Long Term	Medium Term		Min 2 Ply 35mm Header	Min 2 Ply 47mm Header
VHGG-80, VHGG-102, VHGG-118, VHGG-153, VHGG-200	4	8	2.54	35.60	40.00	4.67	66.50	80.20

Code	Description	Box Qty
547389	3.4 x 35mm Square Twist Nails - LOOSE	500
141185	3.4 x 35mm Square Twist Nails - COLLATED*	2,500

\*For use with Paslode PPN35Ci

\*\*Please specify 240mm long bolts when connecting to 4 ply 47mm header members

### Enhanced Uplift

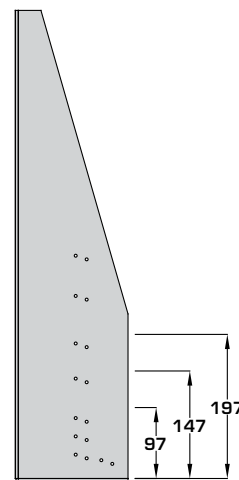

### Dimensions (mm)

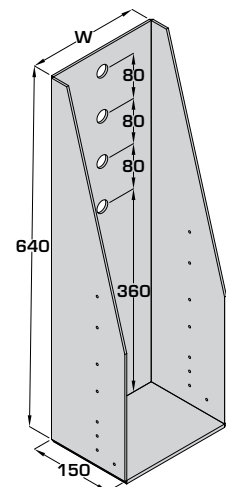

Minimum Truss Bottom Chord Depth (mm)	Fixing (3.4 x 35mm)	Safe Working Loads (kN) Uplift - Short Term	Characteristic Capacity (kN) Uplift
	Incoming		
97	8	2.54	4.67
147	10	4.43	8.49
197	12	7.71	14.72
Vertical	12	8.26	14.72

## Kwiki Hanger Standard Leg

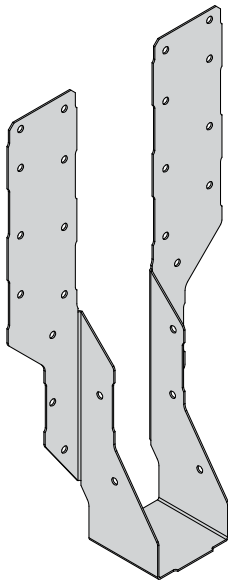

The KH hanger is designed for simple solid timber to timber connections.

### Features & Benefits

- Adjustable leg length accommodates varying timber depths
- Light gauge steel eliminates the need for notching timber

### Material Specification

- Galvanised mild steel - Z275

### Fixings

Code	Description	Box Qty
547389	3.4 x 35mm Square Twist Nails - LOOSE	500
141185	3.4 x 35mm Square Twist Nails - COLLATED*	2,500

\*For use with Paslode PPN35Ci

### Dimensions (mm)

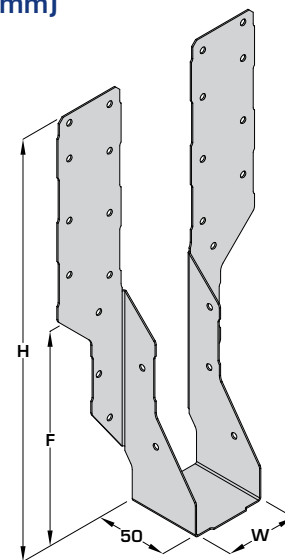

### Available Sizes

Product Code	Minimum Header Depth (mm)	Hanger Width (W) (mm)	Hanger Depth (H) (mm)	Stirrup Height (F) (mm)
KH-38	140	38	271	140
KH-44	140	44	268	137
KH-47	140	47	267	135
KH-50	140	50	265	134
KH-63	140	63	258	128
KH-75	140	75	277	122
KH-92	120	92	269	111
KH-100	120	100	265	109
KH-125	97	125	263	96
KH-150	89	150	250	84

### In Situ

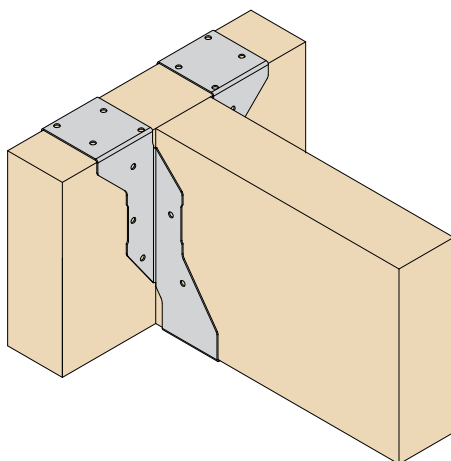

Product not suitable for use with I-Joists or Open Web Joists.

'F' dimension does not support 60% of the joist depth.

### Load Data

Product Code	Fixings (3.4 x 35mm)		Safe Working Loads (kN)			Characteristic Capacity (kN)	
	Header	Incoming	Uplift - Short Term	Solid Timber Header (Min C16)		Uplift	Solid Timber Header (Min TR26/C27)
				Long Term	Medium Term		
KH-38, KH-44, KH-47, KH-50, KH-63, KH-75, KH-92, KH-100, KH-125, KH-150	24	5	2.50	8.20	9.30	4.64	12.48

## Kwiki Hanger Long Leg

European Community  
Registered Design

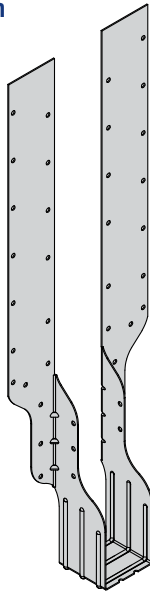

The KHL hanger is a long leg hanger designed for simple solid timber to timber connections.

### Features & Benefits

- Adjustable leg length accommodates varying timber depths
- Solution for dropped/underslung applications

### Material Specification

- Galvanised mild steel - Z275

### Fixings

Code	Description	Box Qty
547389	3.4 x 35mm Square Twist Nails - LOOSE	500
141185	3.4 x 35mm Square Twist Nails - COLLATED*	2,500

\*For use with Paslode PPN35Ci

### Available Sizes

Product Code	Minimum Header Depth (mm)	Hanger Width (W) (mm)	Hanger Depth (H) (mm)	Stirrup Height (F) (mm)
KHL-39	190	38	481	182
KHL-44	190	44	478	179
KHL-47	190	47	476	177
KHL-50	190	50	475	176
KHL-63	170	63	468	169
KHL-75	170	75	462	163
KHL-92	170	92	454	156
KHL-100	170	100	450	151
KHL-125	140	125	437	138
KHL-150	140	150	425	126

### Dimensions (mm)

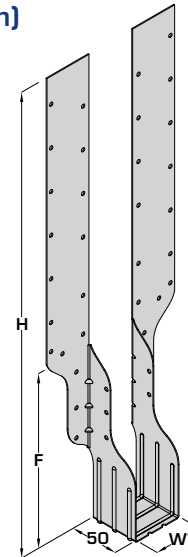

### In Situ

#### Standard Installation

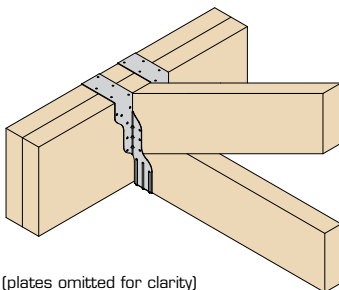

(plates omitted for clarity)

#### Dropped Installation

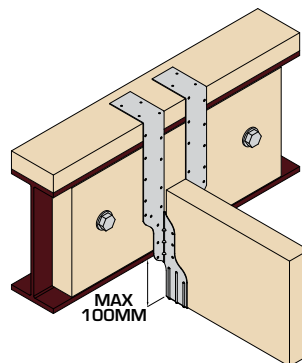

Product not suitable for use with I-Joists.

When supporting open web joists the side flanges (F) must support at least 60% of the joist depth.

Contact Technical Support for further information.

### Load Data

Product Code	Fixings (3.4 x 35mm)		Safe Working Loads (kN)			Characteristic Capacity (kN)	
	Header	Incoming	Uplift - Short Term	Solid Timber Header (Min C16)		Uplift	Solid Timber Header (Min TR26/C27)
				Long Term	Medium Term		
KHL-39, KHL-44, KHL-47, KHL-50, KHL-63, KHL-75, KHL-92, KHL-100	34	5	2.50	11.49	11.49	4.64	18.00
KHL-125, KHL-150	34	5	2.50	11.49	11.49	4.64	15.04

# MH RANGE



## Multi Hanger

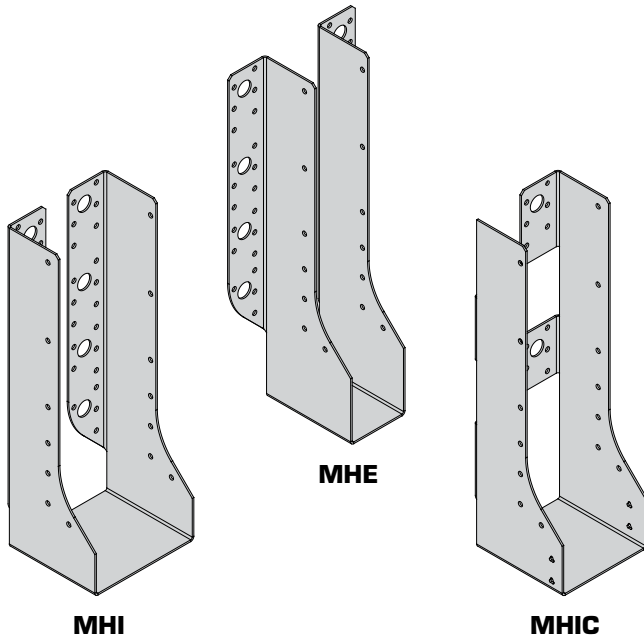

The MH hanger range is designed to support timber to timber connections in medium to high load situations.

### Features & Benefits

- External and internal flange options allow for multifunctional use
- Range of sizes and potential fixing options allows for greater design flexibility
- Partial fixing options available on request. Contact Technical Support.

### Material Specification

- Galvanised mild steel - Z275

### Fixings

Code	Description	Box Qty
547389	3.4 x 35mm Square Twist Nails - LOOSE	500
141185	3.4 x 35mm Square Twist Nails - COLLATED*	2,500
See page 10	M12 Bolts	Each

\*For use with Paslode PPN35Ci

### Available Sizes

Hanger Width (W) (mm)	MHE280	MHI280	MHE380	MHI/MHIC380	MHE490	MHI/MHIC490	MHE620	MHI/MHIC620
39	MHE280-39-120	-	MHE380-39-170	MHIC380-39-170	MHE490-39-225	MHIC490-39-225	MHE620-39-290	MHIC620-39-290
46	MHE280-46-117	-	MHE380-46-167	MHIC380-46-167	MHE490-46-222	MHIC490-46-222	MHE620-46-287	MHIC620-46-287
50	MHE280-50-115	-	MHE380-50-165	MHIC380-50-165	MHE490-50-220	MHIC490-50-220	MHE620-50-285	MHIC620-50-285
55	-	-	-	-	MHE490-55-217	MHIC490-55-217	MHE620-55-282	MHIC620-55-282
61	-	-	MHE380-61-159	MHIC380-61-159	-	MHIC490-61-214	-	MHIC620-61-279
65	-	-	-	MHIC380-65-157	-	MHIC490-65-212	MHE620-65-277	MHIC620-65-277
72	-	-	-	MHIC380-72-154	-	MHIC490-72-209	-	MHIC620-72-274
75	MHE280-75-102	-	MHE380-75-152	MHIC380-75-152	MHE490-75-207	MHIC490-75-207	MHE620-75-272	MHIC620-75-272
78	-	-	MHE380-78-151	MHIC380-78-151	MHE490-78-206	MHIC490-78-206	MHE620-78-271	MHIC620-78-271
92	-	-	MHE380-92-144	MHIC380-92-144	MHE490-92-199	MHIC490-92-199	MHE620-92-264	MHIC620-92-264
100	MHE280-100-90	MHI280-100-90	MHE380-100-140	MHIC380-100-140	MHE490-100-195	MHIC490-100-195	MHE620-100-260	MHIC620-100-260
110	-	-	-	-	MHE490-110-190	MHIC490-110-190	MHE620-110-255	MHIC620-110-255
118	-	-	MHE380-118-131	MHIC380-118-131	MHE490-118-186	MHIC490-118-186	-	-
122	-	-	-	-	MHE490-122-184	MHIC490-122-184	MHE620-122-249	MHIC620-122-249
125	-	-	-	-	MHE490-125-182	MHIC490-125-182	MHE620-125-247	MHIC620-125-247
130	-	-	-	-	-	-	MHE620-130-245	MHIC620-130-245
135	-	-	-	-	MHE490-135-177	MHIC490-135-177	-	-
138	-	-	-	-	MHE490-138-176	MHIC490-138-176	MHE620-138-241	MHIC620-138-241
144	-	-	-	-	-	MHIC490-144-173	MHE620-144-238	-
150	-	-	MHE380-150-115	MHIC380-150-115	MHE490-150-170	MHIC490-150-170	MHE620-150-235	MHIC620-150-235

Hanger Width (W) (mm)	MHE620	MHI620	MHE670	MHI670	MHE720	MHI720
183	MHE620-183-218	MHI620-183-218	-	-	-	-
198	MHE620-198-211	MHI620-198-211	-	-	-	-
210	-	-	MHE670-210-230	-	-	-
225	-	-	MHE670-225-222	MHI670-225-222	-	-
230	-	-	MHE670-230-220	-	-	-
250	-	-	MHE670-250-210	MHI670-250-210	-	-
275	-	-	-	-	MHE720-275-222	MHI720-275-222
300	-	-	-	-	MHE720-300-210	MHI720-300-210

Example: **MHIC620-50-285**  
L W H

L = length  
W = width  
H = height



# MH RANGE



## Multi Hanger

### Hanger Coding

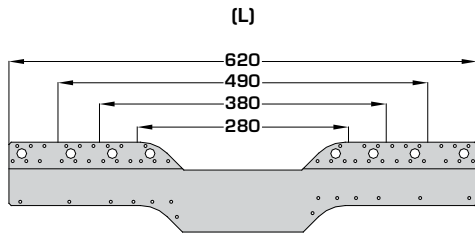

**MHE/MHI FLAT BLANK**  
(280 - 620)

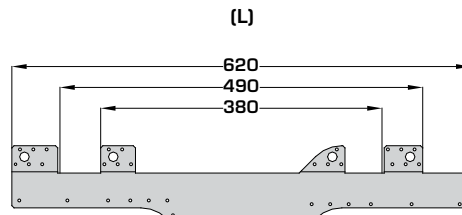

**MHIC FLAT BLANK**

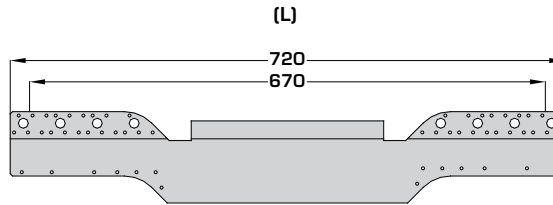
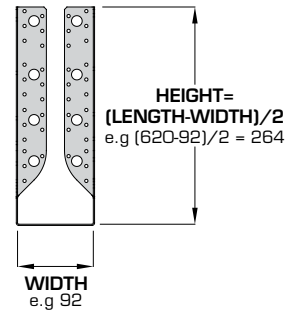

**MHE/MHI FLAT BLANK**  
(670 - 720)

Example: **MHI620-92-264**  
L W H  
L = length  
W = width  
H = height

### Dimensions (mm)

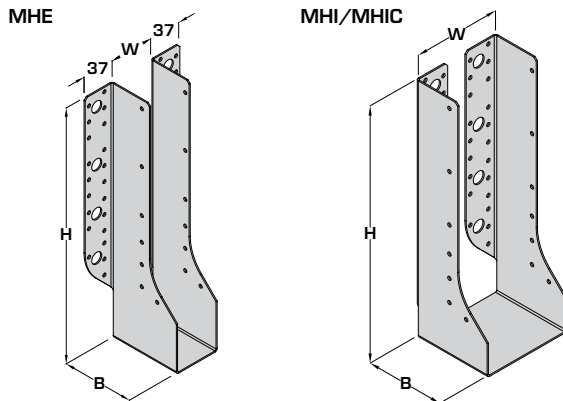

### In Situ

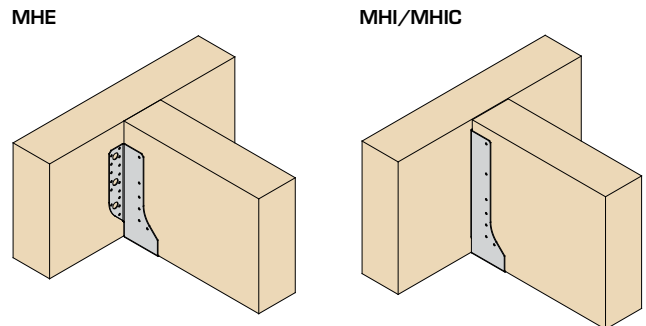

### Load Data

Product Code	Dimensions (mm)			Fixings			Safe Working Loads (kN)			Characteristic Capacity (kN)	
	W		B	Header		Incoming	Uplift - Short Term	Solid Timber Header (Min TR26 / C27)		Uplift	Solid Timber Header (Min TR26 / C27)
	Min	Max		Nails (3.4 x 35mm)	Bolts (M12)			Long Term	Medium Term		
MHE/MHI280	39	100	85	8	0	6	2.54	4.27	4.88	4.67	10.12
				0	2	6		4.17	4.77		10.33
MHE/MHI380	39	150	85	18	0	10	4.43	8.26	9.44	8.49	20.07
				0	4	10		8.70	9.94		17.13
MHE/MHI490	39	100	85	30	0	12	7.71	12.35	14.11	14.72	25.66
				0	6	12		14.48	16.55		33.21
MHE/MHI490	110	150	85	30	0	12	7.71	10.53	12.03	14.72	25.66
				0	6	12		13.36	15.27		27.65
MHE/MHI620	39	100	85	42	0	14	8.26	14.83	16.95	14.72	32.77
				0	8	14		14.53	16.61		35.12
MHE/MHI620	110	150	85	42	0	14	8.26	12.08	13.81	14.72	25.92
				0	8	14		14.53	16.61		35.12
MHE/MHI620	183	198	85	42	0	14	8.26	14.83	16.95	14.72	32.77
				0	8	14		14.53	16.61		35.12
MHE/MHI670	210	250	85	42	0	14	8.26	14.83	16.95	14.72	32.77
				0	8	14		14.53	16.61		35.12
MHE/MHI720	275	300	85	42	0	14	8.26	14.83	16.95	14.72	32.77
				0	8	14		14.53	16.61		35.12
MHIC380	39	78	82	9	0	10	1.05	5.43	6.20	1.98	10.55
MHIC490	39	78	82	16	0	12	1.05	8.96	10.24	1.98	16.76
MHIC620	39	78	82	21	0	14	1.05	10.34	11.81	1.98	21.26

## Flexible Timber Hanger

The FTHI hanger is designed to support joists, trussed rafters and solid timber members in a top fix only application for high load situations.

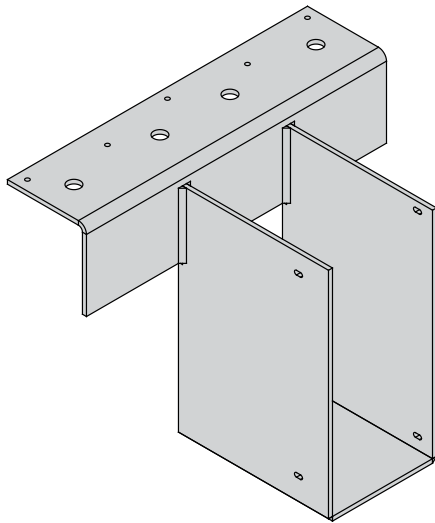

### Features & Benefits

- Increased top flange to allow for greater load distribution
- Options available for skewed, offset, dropped and straddle connections

### Material Specification

- 4mm mild steel with zinc phosphate undercoat with an organic bituminous top coat to BS EN845-1:2013+A1:2016

### Fixings

Code	Description	Box Qty
547389	3.4 x 35mm Square Twist Nails - LOOSE	500
141185	3.4 x 35mm Square Twist Nails - COLLATED*	2,500

\*For use with Paslode PPN35Ci

### Available Sizes

#### Hanger Widths (mm):

39, 46, 50, 61, 65, 72, 75, 78, 92, 100, 122, 125, 130, 138, 144, 150, 183, 198, 222, 225, 250, 300

#### Hanger Depths (mm):

140, 165, 195, 200, 210, 220, 225, 230, 235, 241, 245, 253, 280, 302, 350, 356, 380, 393, 400, 418, 450

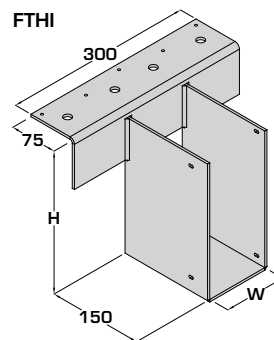

FTHI-W-H

Example:  
FTHI-100-245

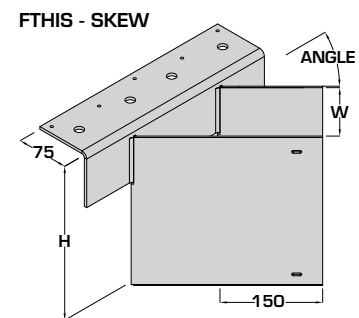

FTHIS-W-H-OFFSET DIRECTIONAL-ANGLE

Example:  
FTHIS-100-245-L-45

### FTHIO - OFFSET

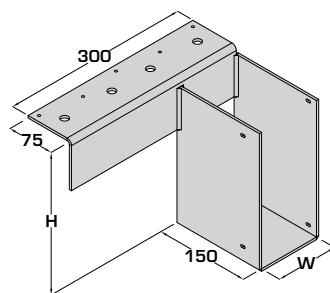

Left hand version shown

FTHIO-W-H-OFFSET DIRECTION

Example:  
FTHIO-100-245-L  
FTHIO-100-245-R

### FTHID - DROPPED

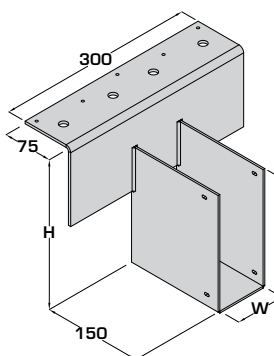

FTHID-W-H-F

Example:  
FTHID-100-245-220

### FTHIST - STRADDLE

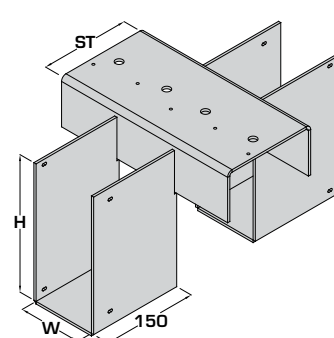

FTHIST-W-H-ST

Example:  
FTHIST-100-245-140

### Load Data

Product Code	Fixings (3.4 x 35mm)		Safe Working Loads (kN)			Characteristic Capacity (kN)	
	Header	Incoming	Uplift	LVL or GL (Min GL28)		Uplift	LVL or GL (Min GL28)
				Long Term	Medium Term		
FTHI	5	2	1.00	22.85	25.55	2.00	42.00

## Angle Bracket



The LAB is a 90° angle bracket to accommodate various timber to timber connections.

### Features & Benefits

- Multiple holes to accommodate nail, screw and bolt fixings

### Material Specification

- Galvanised mild steel - Z275

### Fixings

Code	Description	Box Qty
547389	3.4 x 35mm Square Twist Nails - LOOSE	500
141185	3.4 x 35mm Square Twist Nails - COLLATED*	2,500
547297	3.35 x 50mm Ring Shank Nails	250

\*For use with Paslode PPN35Ci

3.5 x 30mm wood screws - supplied by others

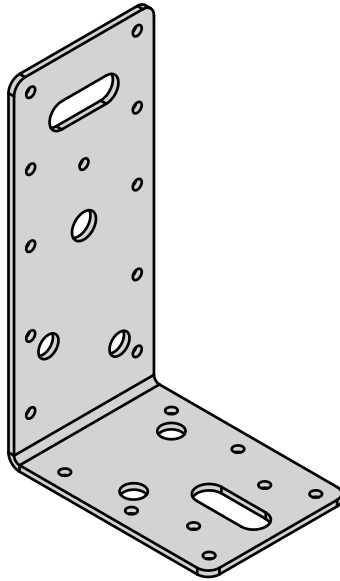

### In Situ

Horizontal:

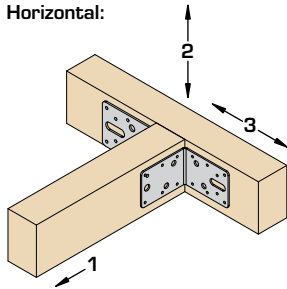

Vertical:

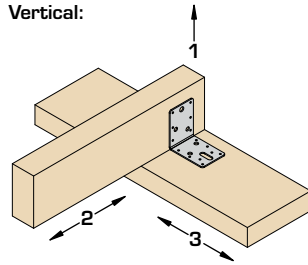

### Dimensions (mm)

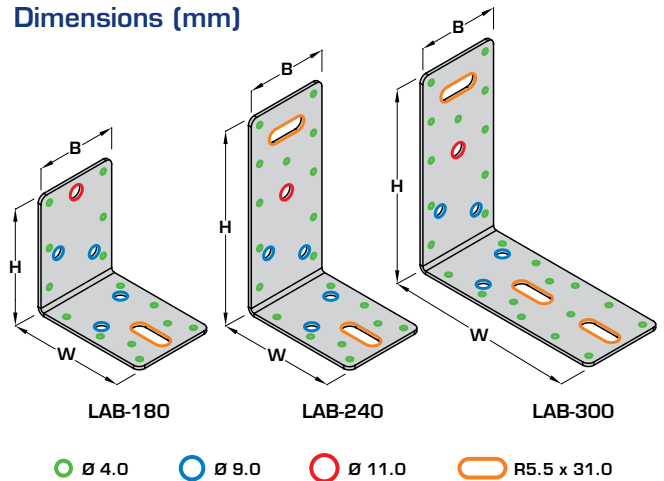

### Load Data (all loads are per pair of angle brackets)

Product Code	Dimensions (mm)			Fixings (3.4 x 35mm Square Twist Nails)		Load Direction	Safe Working Loads (kN)		Characteristic Capacity (kN)
	W	H	B	Header	Incoming		Solid Timber Header (Min C24)		
							Long Term	Medium Term	
LAB-180	90	90	63	12	16	1	1.29	1.47	3.32
						2	3.84	4.39	9.62
						3	4.22	4.82	10.12
LAB-240	150	90	63	22	16	1	1.45	1.66	4.16
						2	4.99	5.70	12.39
						3	4.22	4.82	10.12
LAB-300	150	150	63	22	26	1	1.45	1.66	4.16
						2	4.99	5.70	12.39
						3	5.50	6.30	13.50
				Fixings (3.35 x 50mm Ring Shank)					
				Header	Incoming				
LAB-180	90	90	63	12	16	1	2.96	3.38	7.27
LAB-240	150	90	63	22	16	1	3.28	3.75	7.97
LAB-300	150	150	63	22	26	1	3.28	3.75	7.97
				Fixings (3.35 x 30mm Wood Screw)					
				Header	Incoming				
LAB-180	90	90	63	12	16	1	2.00	2.29	6.40
LAB-240	150	90	63	22	16	1	2.51	2.87	6.40
LAB-300	150	150	63	22	26	1	2.51	2.87	6.40

# SA-45



## Skewed Angle 45° Hanger

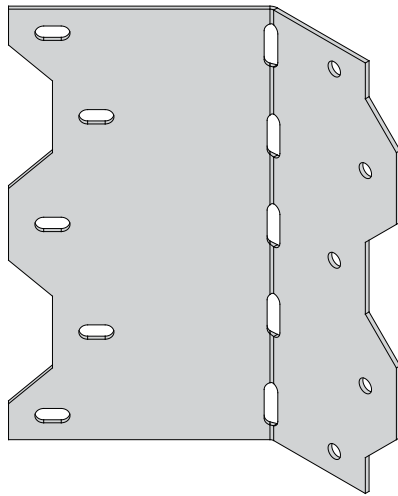

The SA-45 is a 45 degree pre-bent angle bracket for light load timber to timber connections.

### Features & Benefits

- Adjustable between 45 - 90 degrees for angles 45 - 135 degrees (to be bent once)

### Material Specification

- Galvanised mild steel - Z275

### Fixings

Code	Description	Box Qty
547389	3.4 x 35mm Square Twist Nails - LOOSE	500
141185	3.4 x 35mm Square Twist Nails - COLLATED*	2,500

\*For use with Paslode PPN35Ci

3.75 x 75mm round wire nails - for enhanced installation

### In Situ

#### Standard 45°

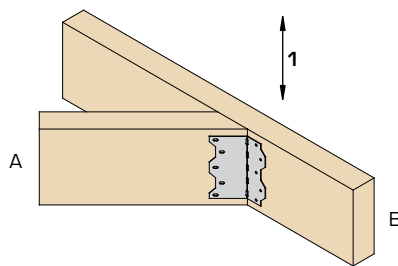

#### Standard 90°

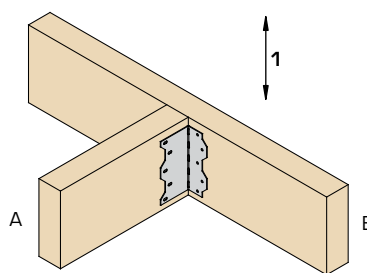

### Dimensions (mm)

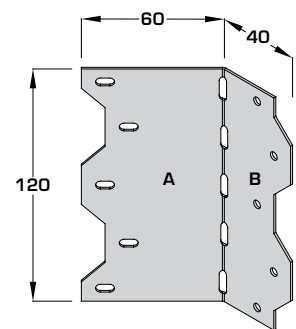

#### Enhanced 45°

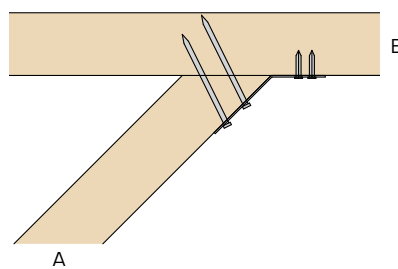

Joist A - 3.75 x 75mm round wire nails  
Joist B - 3.4 x 35mm square twist nails

### Incorrect Installation

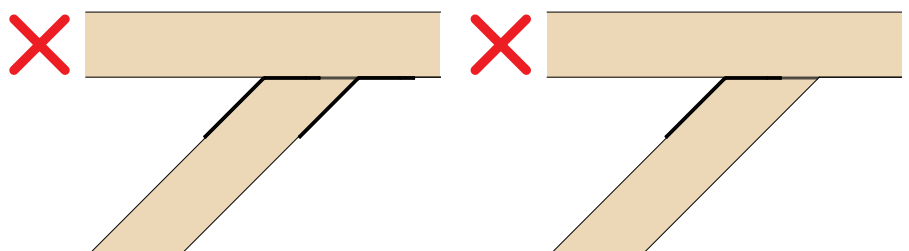

Do not use more than one bracket per connection.

Do not install bracket on the acute side of the angle.

### Load Data

	Angle	Load Direction	Fixings		Safe Working Loads (kN)		Characteristic Capacity (kN)
			Joist (A)	Joist (B)	Solid Timber Header (Min TR26)		Solid Timber Header (Min TR26)
					Long Term	Medium Term	
STANDARD INSTALL	45°	1	5No 3.4 x 35mm	5No 3.4 x 35mm	1.81	2.07	4.02
	90°	1	5No 3.4 x 35mm	5No 3.4 x 35mm	1.70	1.94	3.49
ENHANCED INSTALL	45°	1	5No 3.75 x 75mm	5No 3.4 x 35mm	3.43	3.92	5.84

Contact Technical Support for angles outwith 45° and 90°



# 45L/R



## Face Fix 45° Hanger



The 45L/R is a pre-skewed 45 degree hanger for timber to timber connections.

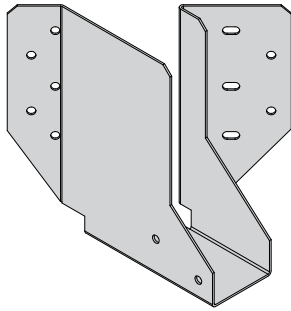

85 - 170mm Deep

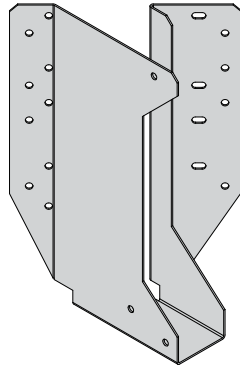

220 - 300mm Deep

Left hand version shown

### Features & Benefits

- Economical solution provides set angle for ease of installation

### Material Specification

- Galvanised mild steel - Z275

### Fixings

Code	Description	Box Qty
547389	3.4 x 35mm Square Twist Nails - LOOSE	500
141185	3.4 x 35mm Square Twist Nails - COLLATED*	2,500

\*For use with Paslode PPN35Ci

### Available Sizes

Hanger Width (W) (mm)	Hanger Depth (H) (mm)									
	85		135		170		220		300	
	Left	Right	Left	Right	Left	Right	Left	Right	Left	Right
39	45-L-39-85	45-R-39-85	45-L-39-135	45-R-39-135	45-L-39-170	45-R-39-170	45-L-39-220	45-R-39-220	45-L-39-300	45-R-39-300
46	45-L-46-85	45-R-46-85	45-L-46-135	45-R-46-135	45-L-46-170	45-R-46-170	45-L-46-220	45-R-46-220	45-L-46-300	45-R-46-300
50	45-L-50-85	45-R-50-85	45-L-50-135	45-R-50-135	45-L-50-170	45-R-50-170	45-L-50-220	45-R-50-220	45-L-50-300	45-R-50-300
75	45-L-75-85	45-R-75-85	45-L-75-135	45-R-75-135	45-L-75-170	45-R-75-170	45-L-75-220	45-R-75-220	45-L-75-300	45-R-75-300
92	45-L-92-85	45-R-92-85	45-L-92-135	45-R-92-135	45-L-92-170	45-R-92-170	45-L-92-220	45-R-92-220	45-L-92-300	45-R-92-300
100	45-L-100-85	45-R-100-85	45-L-100-135	45-R-100-135	45-L-100-170	45-R-100-170	45-L-100-220	45-R-100-220	45-L-100-300	45-R-100-300

See VS (pages 118 - 119) or VRC (pages 88 - 89) for skews outwith 45°

Left Hand:

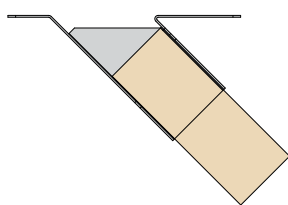

Right Hand:

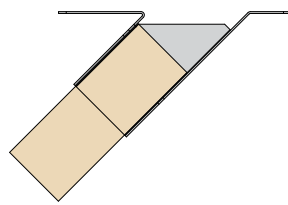

In Situ

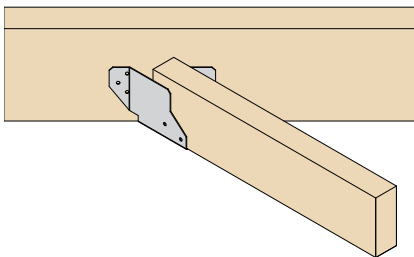

### Dimensions (mm)

85-170mm Deep

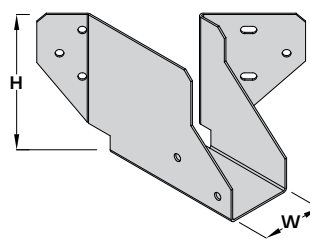

220-300mm Deep

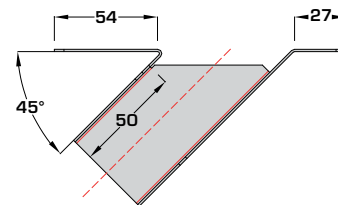
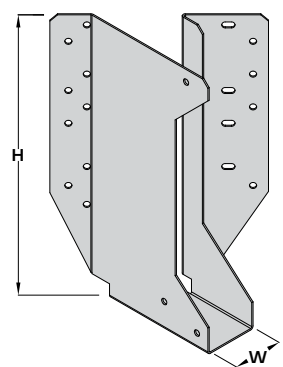

### Load Data

Hanger Depth (H) (mm)	Fixings (3.4 x 35mm)		Safe Working Loads (kN)		Characteristic Capacity (kN)		
	Header	Incoming	Uplift - Short Term	Solid Timber Header (Min C20)		Uplift	Solid Timber Header (Min C20)
				Long Term			
85	6	2	0.80	2.09		0.99	5.71
135	10	2	0.80	3.72		0.99	9.36
170	14	2	0.80	5.55		0.99	12.33
220	17	3	0.80	6.93		0.99	14.73
300	21	3	0.80	6.93		0.99	17.54



## Variable Skewed Timber Hanger

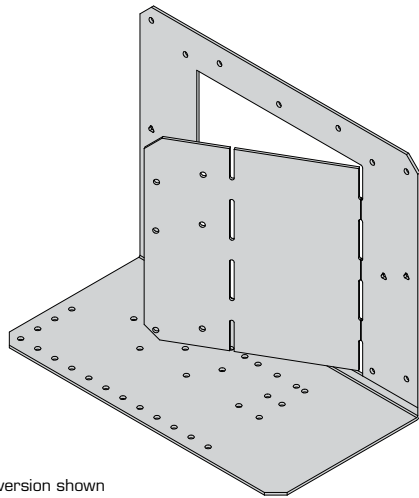

Right hand version shown

The VS hanger is used to support joists and trusses up to 97mm wide from solid timber members in skewed applications between 30-90°.

### Features & Benefits

- Unique hanger design provides a variable skew angle between 30-90°
- No need to mitre cut joists
- Angle scale on base to ease adjustment

### Material Specification

- Galvanised mild steel - Z275

### Fixings

Code	Description	Box Qty
547389	3.4 x 35mm Square Twist Nails - LOOSE	500
141185	3.4 x 35mm Square Twist Nails - COLLATED*	2,500

\*For use with Paslode PPN35C

### Available Sizes

Min Joist Width (mm)	Max Joist Width (mm)	Handing	Hanger Depth (mm)			
			135	175	195	220
38	97	Right	VS-135-R	VS-175-R	VS-195-R	VS-220-R
38	97	Left	VS-135-L	VS-175-L	VS-195-L	VS-220-L
>97		See FTHIS on page 114				

### Dimensions (mm)

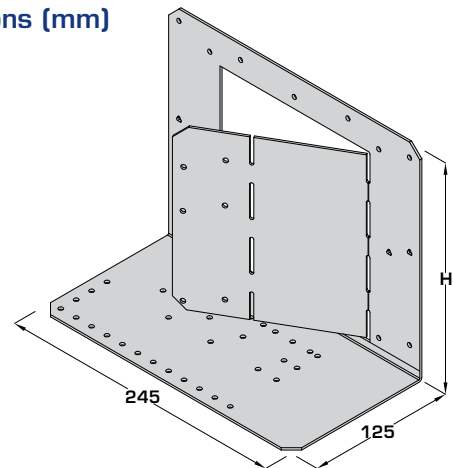

#### Left Hand

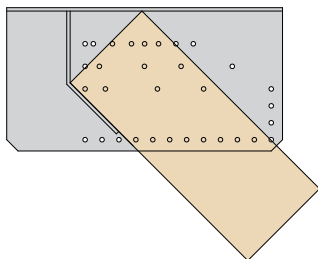

#### Right Hand

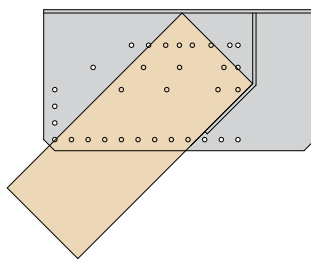

### In Situ

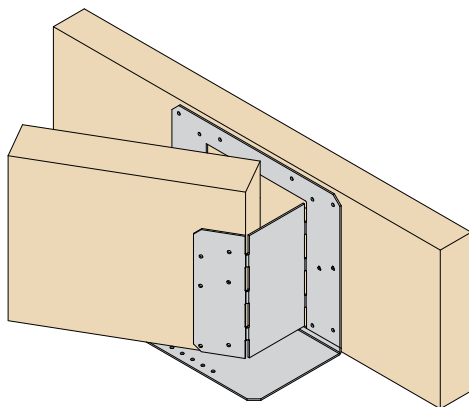

Solid timber joists must be full depth of hanger

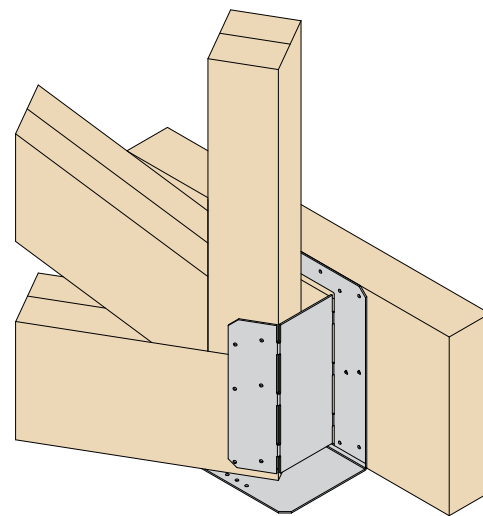

Bottom chord must be deeper than hanger or vertical required for trusses

## Variable Skewed Timber Hanger

### Load Data

Hanger Depth (mm)	Fixings (3.4 x 35mm)		Safe Working Loads (kN)			Characteristic Capacity (kN)	
			Uplift - Short Term	Solid Timber Header (Min TR26)		Uplift	Solid Timber Header (Min TR26)
				Long Term	Medium Term		
135	11	4	2.50	3.35	3.71	2.50	4.30
175, 195, 220	11	6	2.50	4.16	4.75	3.75	5.51

### Installation Instructions

#### STAGE 1

Adjust side plate to approximate angle between 30° and 90° using scale on base of hanger, bending only once. Please refer to the angle table below to determine if one or two bends are required.

Joist Width (mm)	Single Bend		Double Bend
	Single bend	Double Bend	
35	n/a	30-90°	
38	n/a	30-90°	
44	n/a	30-90°	
45	n/a	30-90°	
47	n/a	30-90°	
51	30-32°	>32-90°	
53	30-32°	>32-90°	
58	30-34°	>34-90°	
59	30-34°	>34-90°	
60	30-34°	>35-90°	
63	30-37°	>37-90°	
70	30-39°	>39-90°	
72	30-40°	>40-90°	
76	30-42°	>42-90°	
88	30-46°	>46-90°	
89	30-46°	>46-90°	
90	30-46°	>46-90°	
94	30-48°	>48-90°	
97	30-49°	>49-90°	

#### STAGE 2

Position hanger against face of joist/truss and nail using 11No 3.4 x 35mm square twist nails.

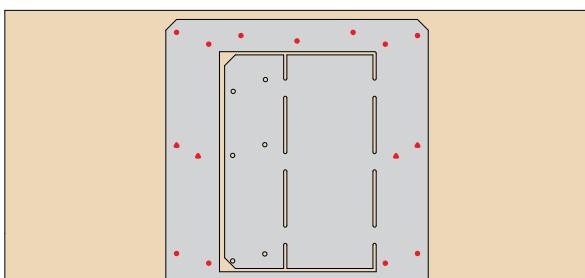

#### STAGE 3

Locate incoming member and adjust side plate to correct angle, ensuring maximum gap between incoming joist/truss and back plate is no greater than 3mm.

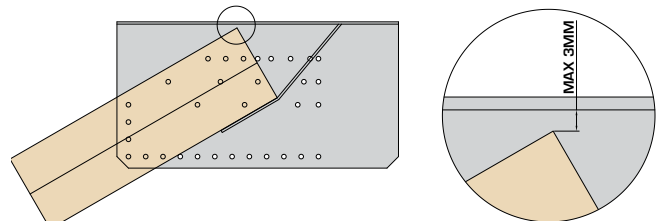

Max - 3mm gap at any given time

#### STAGE 4

Fix to incoming member using 6No 3.4 x 35mm square twist nails (4No for VS-135).

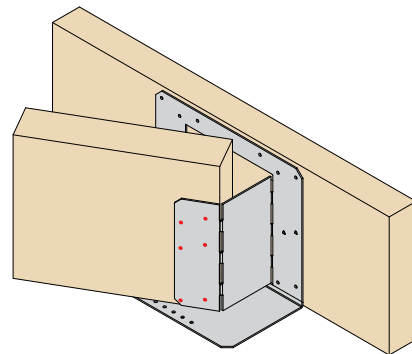

Please ensure that 1No inner nail hole (indicated in red) and 1No outer nail hole (indicated in red) are filled on the underside with 3.4 x 35mm square twist nails.

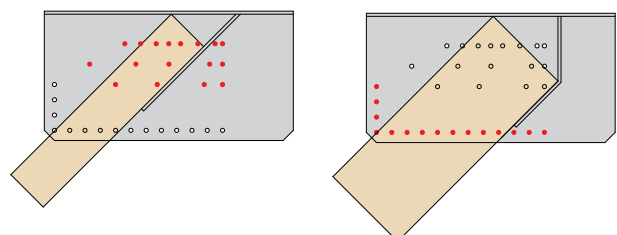

## Nail Plate

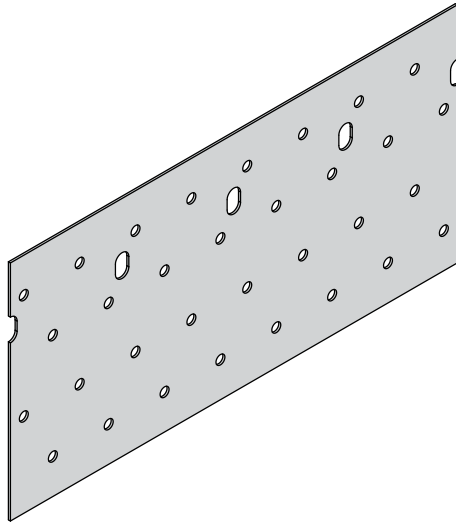

The NP nail plate allows the connection of two or more timber members.

### Features & Benefits

- Part can be hand nailed on site for truss remedials

### Material Specification

- Galvanised mild steel - Z275 - 0.9mm thick

### Fixings

Code	Description	Box Qty
547389	3.4 x 35mm Square Twist Nails - LOOSE	500
141185	3.4 x 35mm Square Twist Nails - COLLATED*	2,500

\*For use with Paslode PPN35Ci

### Available Sizes

Nail Plate Length (L) (mm)	Nail Plate Width (W) (mm)			
	80	100	150	200
100	NP-80-100	NP-100-100	NP-150-100	-
200	NP-80-200	NP-100-200	NP-150-200	NP-200-200
300	NP-80-300	NP-100-300	NP-150-300	NP-200-300
400	NP-80-400	NP-100-400	NP-150-400	NP-200-400
500	NP-80-500	NP-100-500	NP-150-500	NP-200-500

### Dimensions (mm)

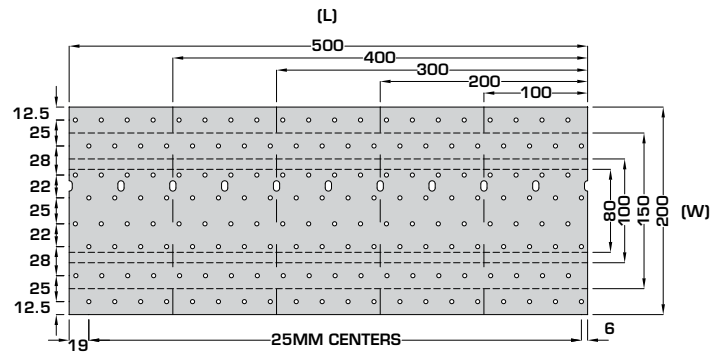

### In Situ

- Timber to timber joints for use in trussed rafter roofs must be designed in accordance with BS5268-2:2002 & BS5268-3:2006
- Nails must meet edge distance requirements to have load carrying capacity
- A nail plate should be positioned on each side of the joint. Care should be taken to ensure there are equal nails fixed from each side and no nail clashes

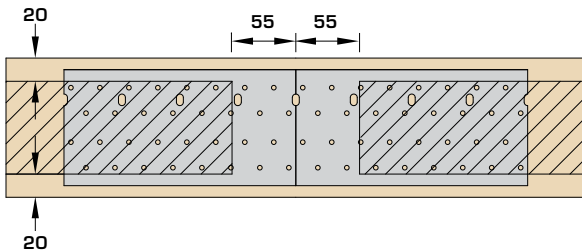

BUTT JOINTS

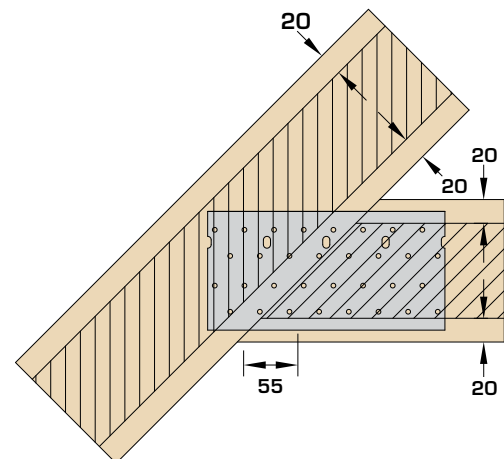

HEEL JOINTS



## Support Bracket

The **SB** support bracket is used to form a connection between timber bracing shelves and the adjacent trussed rafters.

### Features & Benefits

- Unique design allows one part to accommodate any rafter width
- Can be connected to timber shelf at ground floor level to ease with installation

### Material Specification

- Galvanised mild steel - Z275

### Fixings

Code	Description	Box Qty
547389	3.4 x 35mm Square Twist Nails - LOOSE	500
141185	3.4 x 35mm Square Twist Nails - COLLATED*	2,500

\*For use with Paslode PPN35C

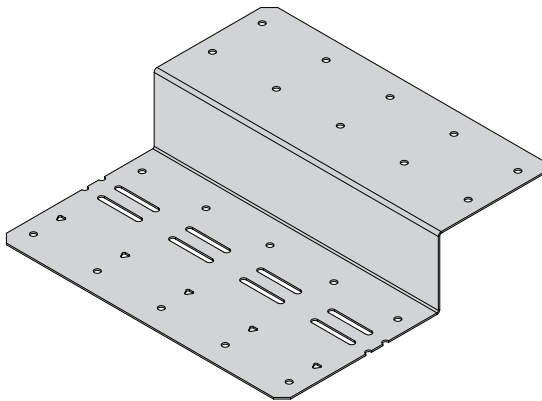

### Available Sizes

Product Code	Min Truss Width (mm)	Max Truss Width (mm)
SB	35	188

### Dimensions (mm)

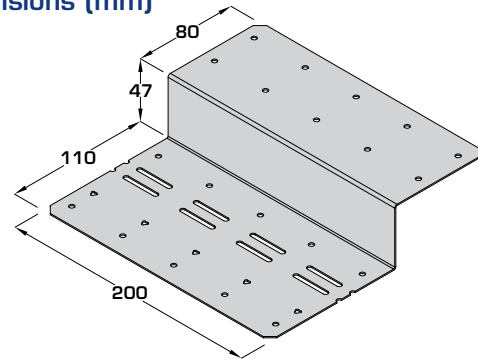

### Installation Instructions

- BS5268-3:2006 (Annex A) states that a bracing solution for roof spans up to 17m requires steel support bracket to form a connection between the timber bracing shelves and adjacent rafters (Refer to standard for fixing diagonal bracing to bracing shelf)

#### STAGE 1

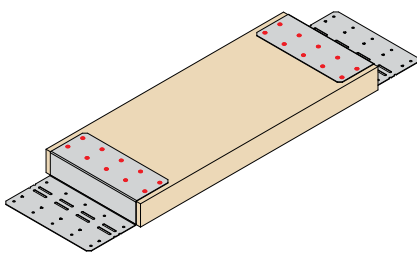

Nail support bracket to timber bracing shelf (min C16 grade) with 10No fixings per bracket (3.4 x 35mm square twist nails).

#### STAGE 2

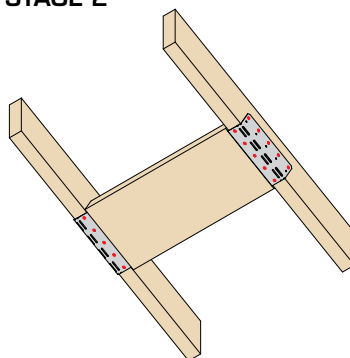

#### Single Rafter

Position timber bracing shelf in-between rafters and nail to underside with 5No fixings per bracket (3.4 x 35mm square twist nails).

Wipe the support bracket round the rafter and nail into the side of the rafter with 5No fixings per bracket (3.4 x 35mm square twist nails).

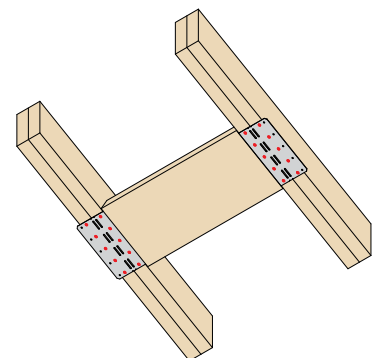

#### Multiple Rafters

Position timber bracing shelf in-between rafters and nail to underside with 10No fixings per bracket (3.4 x 35mm square twist nails).

# Wallplate Connection Overview

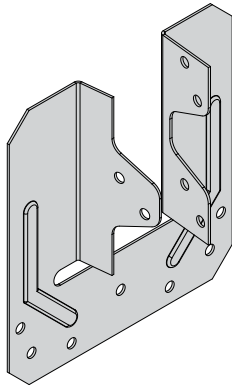

**TC**  
Page 123

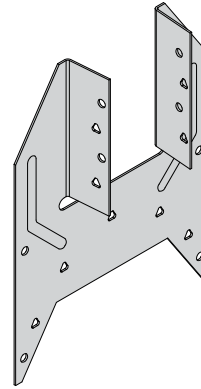

**TA**  
Page 124

## SINGLE 35 & 47MM WIDE TRUSSES

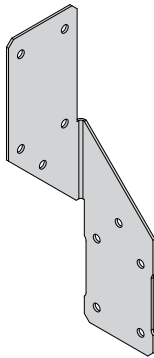

**TA-1**  
Page 125

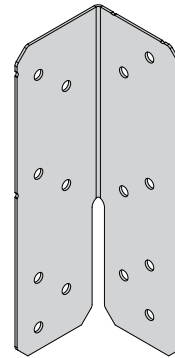

**FAS**  
Page 127

## NON WIDTH DEPENDANT

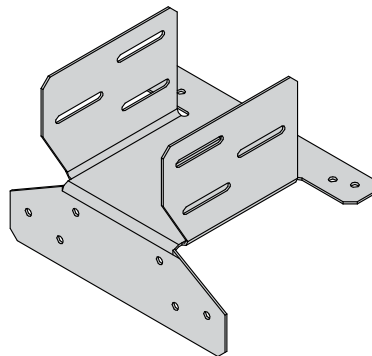

**SS**  
Page 126

## RAISED TIE / SCISSOR TRUSSES

## Truss Clip



The TC is our standard truss clip for securing trussed rafters to single wall plates.

### Features & Benefits

- Eliminates damage from skew nailing into the wall plate

### Material Specification

- Galvanised mild steel - Z275

### Fixings

Code	Description	Box Qty
547389	3.4 x 35mm Square Twist Nails - LOOSE	500
141185	3.4 x 35mm Square Twist Nails - COLLATED*	2,500

\*For use with Paslode PPN35Ci

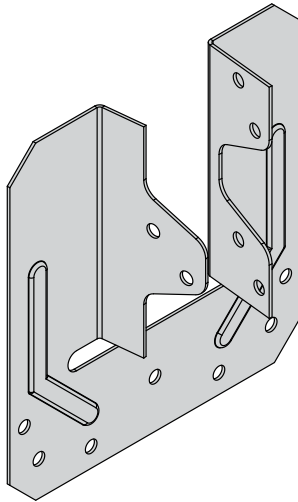

### Available Sizes

Product Code	Truss Width (mm)
TC-38	35
TC-50	44-47

### Dimensions (mm)

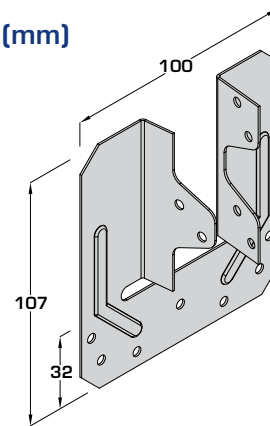

### In Situ

#### 1 No truss clip\*\*\*

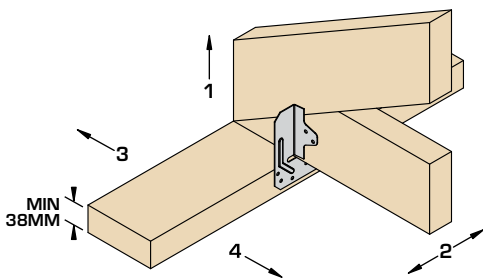

#### 2 No truss clips\*\*\*

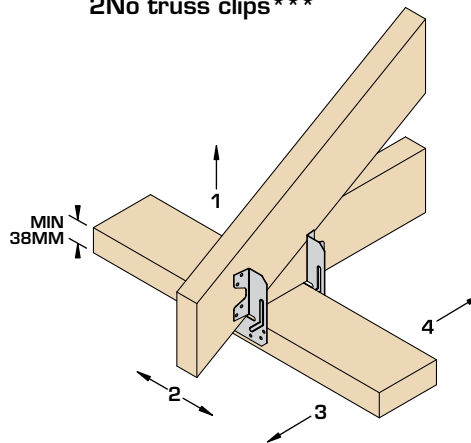

#### Incorrect Installation

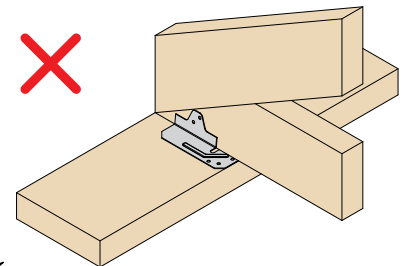

Do not install truss clips horizontally onto the wall plate

\*\*\*Also suitable to fix to the outside of the wall plate depending on truss heel detail.

(Plates omitted for clarity)

### Load Data

Product Code	Fixings (3.4 x 35mm)		Safe Working Loads (kN)		Characteristic Capacity (kN)
	Header	Incoming	Load Direction	Solid Timber Header (Min C16)	Solid Timber Header (Min C16)
				Short Term	
TC-38/TC-50	6	6	1	2.35 (4.70**)	5.13 (10.26**)
			2	0.90 (1.80**)	2.00 (4.00**)
			3	1.29 (1.74**)	0.70 (2.37**)
			4	0.45 (1.74**)	1.67 (2.37**)

\*\*Values for 2No truss clips.

## Truss Anchor



The TA secures trussed rafters to 2 ply wall plates or head binders whilst providing a positive fixing on two planes.

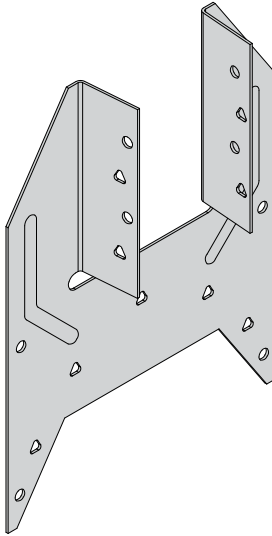

### Features & Benefits

- Eliminates damage from skew nailing into the wall plate
- “Push on” fit allows truss anchor to be retained in position prior to nailing
- Optional triangular nail holes for enhanced performance

### Material Specification

- Galvanised mild steel - Z275

### Fixings

Code	Description	Box Qty
547389	3.4 x 35mm Square Twist Nails - LOOSE	500
141185	3.4 x 35mm Square Twist Nails - COLLATED*	2,500

\*For use with Paslode PPN35Ci

### Available Sizes

Product Code	Truss Width (mm)	W (mm)
TA-38	35	100
TA-50	47	113

### In Situ

Double wall plate required for all installations (min 75mm) unless using in a timber frame application where the framing anchor can be fitted to the head binder.

### Dimensions (mm)

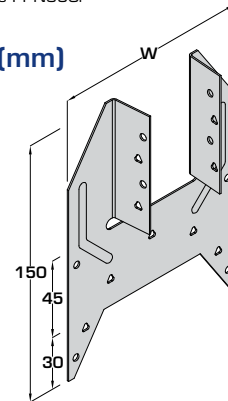

### Standard Installation

(Fill all circular nail holes)

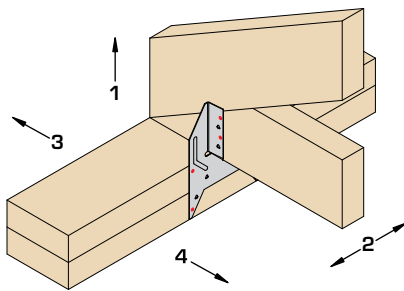

(Plates omitted for clarity)

### Enhanced Installation

(Fill all nail holes)

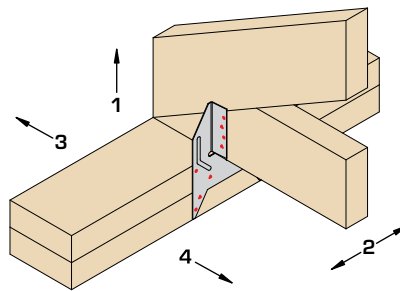

### 2No Truss Anchors

(Dependant on truss heel)

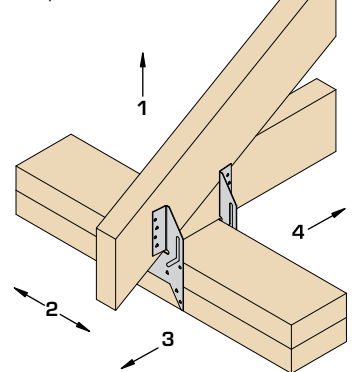

### Load Data

Product Code	Installation	Fixings (3.4 x 35mm)		Safe Working Loads (kN)		Characteristic Capacity (kN)
		Header	Incoming	Load Direction	Solid Timber Header (Min C16)	Solid Timber Header (Min C16)
					Short Term	
TA-38, TA-50	STANDARD INSTALL	4	4	1	2.40 (4.80**)	3.48 (6.96**)
				2	0.90 (1.80**)	3.39 (6.78**)
				3	1.29 (1.74**)	0.78 (1.35**)
				4	0.45 (1.74**)	0.57 (1.35**)
TA-38, TA-50	ENHANCED INSTALL	9	8	1	4.30 (8.60**)	7.54 (15.08**)
				2	1.93 (3.86**)	4.17 (8.34**)
				3	1.29 (2.40**)	2.10 (4.29**)
				4	1.11 (2.40**)	2.19 (4.29**)

\*\*Values for 2No truss anchors

# TA-1



## Framing Anchor



The TA-1 provides a positive connection on two planes without encroaching into the internal space.

### Features & Benefits

- Eliminates damage from skew nailing
- Single anchor means the part is not width dependant

### Material Specification

- Galvanised mild steel - Z275

### Fixings

Code	Description	Box Qty
547389	3.4 x 35mm Square Twist Nails - LOOSE	500
141185	3.4 x 35mm Square Twist Nails - COLLATED*	2,500

\*For use with Paslode PPN35CI

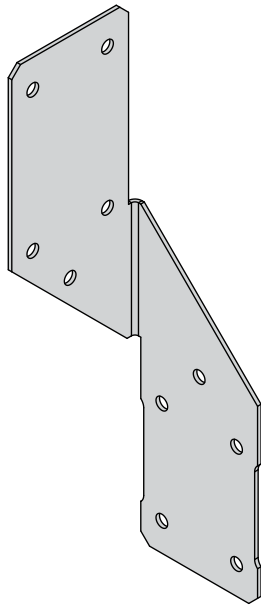

### Dimensions (mm)

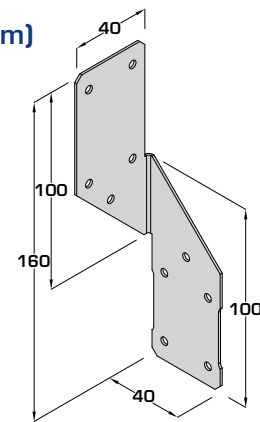

### In Situ

Double wall plate required for all installations (min 75mm) unless using in a timber frame application where the framing anchor can be fitted to the head binder.

#### 1No TA-1 standard installation\*\*

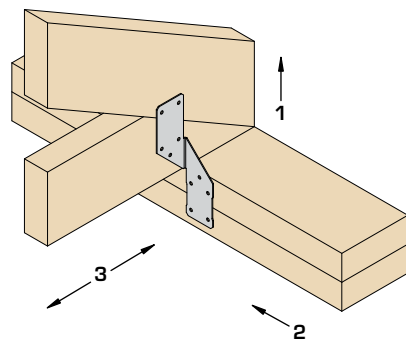

#### 1No TA-1 installed to opposite side\*\*

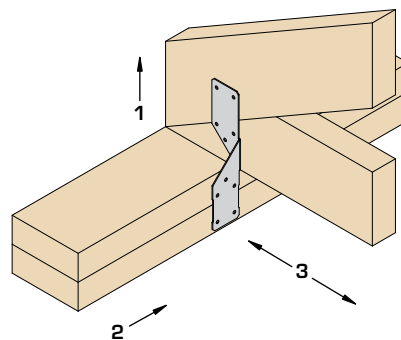

#### 1No TA-1 installed to outer face\*\*

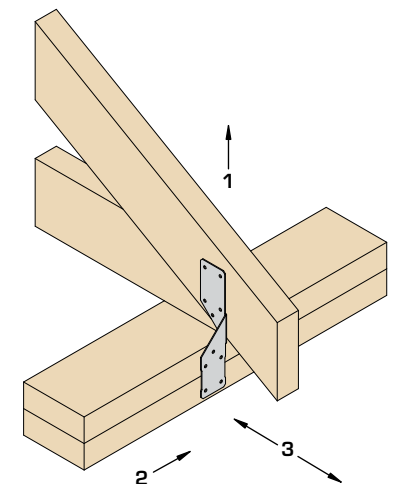

\*\*Also suitable to fix to the outside of the wall plate depending on truss heel detail.

(Plates omitted for clarity)

### Load Data

Product Code	Fixings (3.4 x 35mm)		Safe Working Loads (kN)		Characteristic Capacity (kN)
	Header	Incoming	Load Direction	Solid Timber Header (Min C20)	Solid Timber Header (Min C20)
				Short Term	
TA-1	5	5	1	1.53	3.12
			2	0.88	1.55
			3	1.10	1.84

All values are per anchor.



## Slide Shoe



The **SS** allows for a secure fixing and horizontal movement between raised tie/scissor trusses and the wallplate.

### Features & Benefits

- Provides a maximum of 26mm lateral movement without compromising its resistance to uplift

### Material Specification

- Galvanised mild steel - Z275

### Fixings

Code	Description	Box Qty
547389	3.4 x 35mm Square Twist Nails - LOOSE	500
141185	3.4 x 35mm Square Twist Nails - COLLATED*	2,500

\*For use with Paslode PPN35C

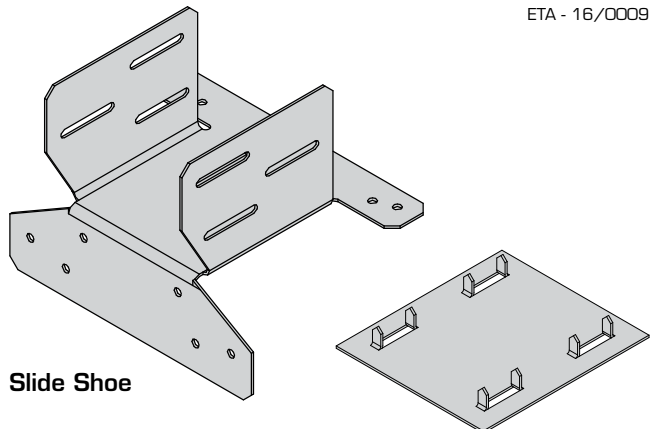

Slide Shoe

Plate (Supplied with SS)

### Available Sizes

Product Code	Truss Width (mm)	Hanger Width (W) (mm)
SS-38	35	38
SS-50	47	50
SS-75	70 (2 ply 35)	75
SS-100	94 (2 ply 47)	100
SS-150	141 (3 ply 47)	150
SS-200	188 (4 ply 47)	200

### Dimensions (mm)

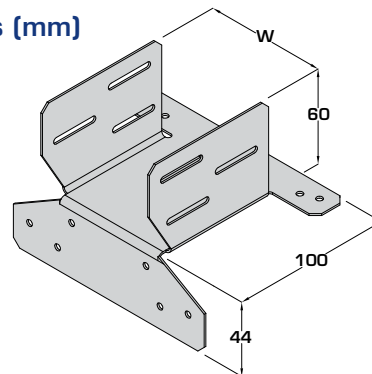

### Installation Instructions

Typically used on one or both ends of the truss as determined by the Truss Designer.

#### STAGE 1

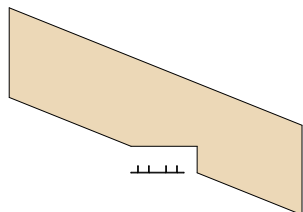

Tap bearing plate into position on underside of truss bearing area

#### STAGE 2

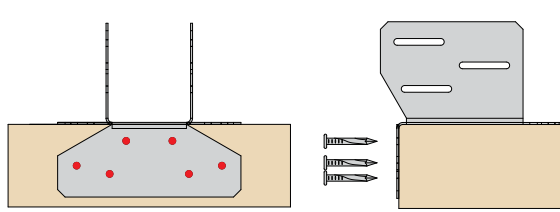

Position the slide shoe on the wall plate and nail to either face with 6No 3.4x35mm square twist nails

#### STAGE 3

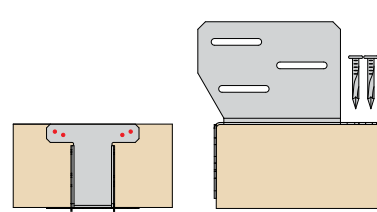

Nail to the top of the wall plate with 4No 3.4x35mm square twist nails

#### STAGE 4

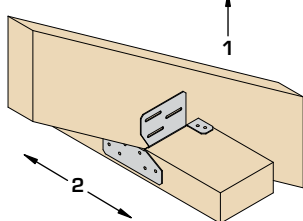

Locate truss in position

#### STAGE 5

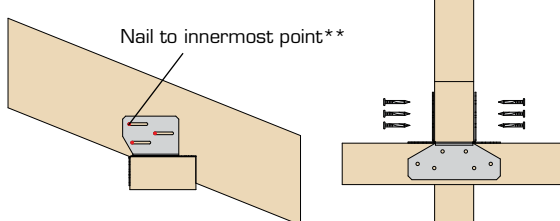

Nail through side flanges into the rafter with 6No 3.4x35mm square twist nails

\*\*Allows the rafter to deflect and therefore there is no horizontal thrust transferred into the wall head

### Load Data

Product Code	Fixings (3.4 x 35mm)		Safe Working Loads (kN)		Characteristic Capacity (kN)
	Header	Incoming	Load Direction	Solid Timber Header (Min TR26)	Solid Timber Header (Min TR26)
				Short Term	
SS-38, SS-50, SS-75, SS-100, SS-150, SS-200	10	6	1	2.42	4.10
			2	1.61	2.60

## Framing Anchor



The FAS is an adjustable connector for providing a positive fixing on two planes.

### Features & Benefits

- Eliminates damage from skew nailing
- Adjustable bend to accommodate various applications

### Material Specification

- Galvanised mild steel - Z275

### Fixings

Code	Description	Box Qty
547389	3.4 x 35mm Square Twist Nails - LOOSE	500
141185	3.4 x 35mm Square Twist Nails - COLLATED*	2,500

\*For use with Paslode PPN35CI

### Dimensions (mm)

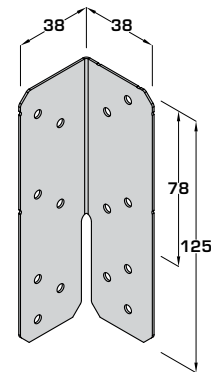

### In Situ

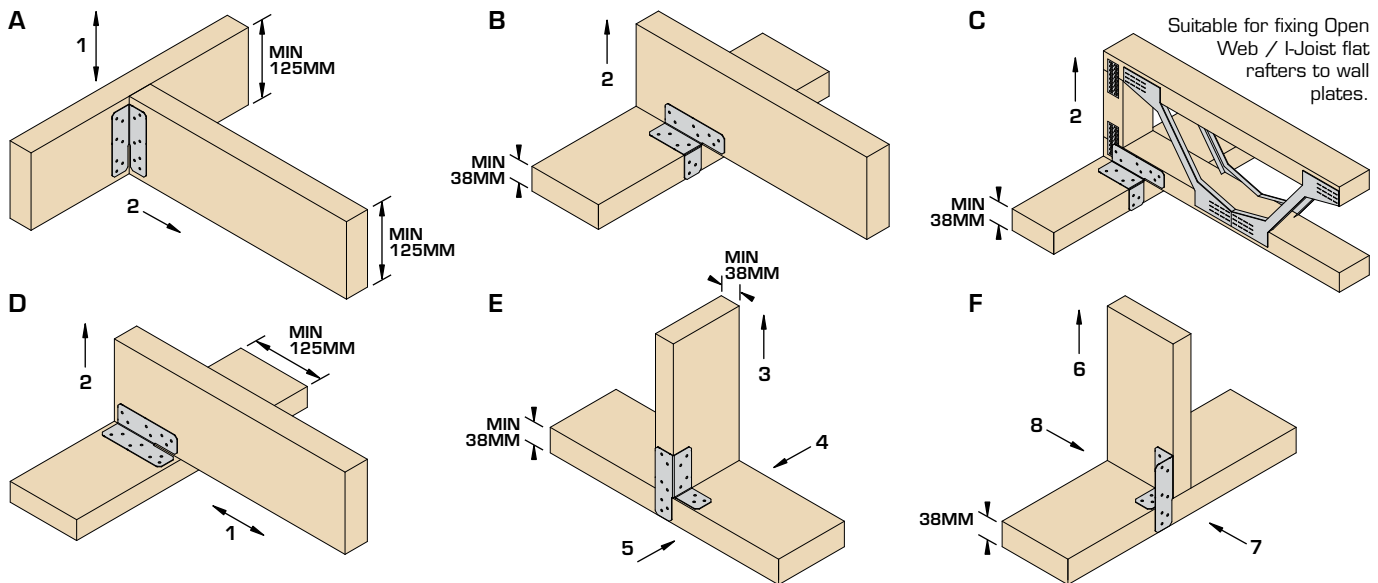

### Load Data

Product Code	Fixings (3.4 x 35mm)		Safe Working Loads (kN) - Per Pair of Anchors				Characteristic Capacity (kN) - Per Pair of Anchors
			Load Direction	Solid Timber Header (Min TR26)			
	Header	Incoming		Long Term	Medium Term	Short Term	Solid Timber Header (Min TR26)
FAS	7	7	1	3.84	4.40	4.60	5.83
			2	2.16	2.48	2.59	3.40
	6	8	3	2.74	3.14	3.28	8.10
			4	2.20	2.52	2.64	3.35
			5	1.24	1.42	1.48	1.44
	6	4	6	2.74	3.14	3.28	8.10
			7	0.94	1.08	1.12	1.16
			8	2.28	2.60	2.73	0.89

# Restraint Strap Overview

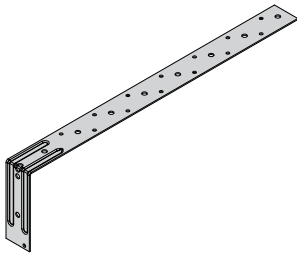

**PFS**  
Page 136

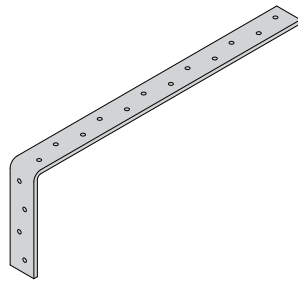

**HDGS**  
Page 139

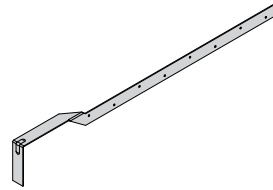

**PST**  
Page 137

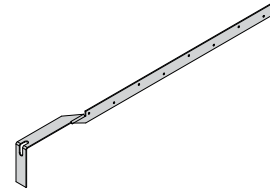

**PSC**  
Page 137

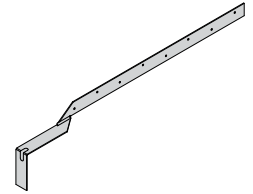

**PSB**  
Page 137

**LATERAL RESTRAINT PERPENDICULAR - FLOORS & ROOFS**

**LATERAL RESTRAINT PARALLEL - FLOORS**

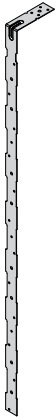

**VRS**  
Page 134

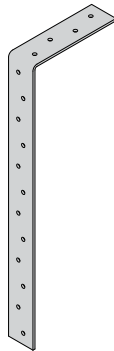

**LDGS**  
Page 138



**RST-1**  
Page 135

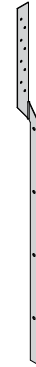

**RST-2**  
Page 135



**RST-3**  
Page 135

**VERTICAL RESTRAINT**

**UPLIFT RESISTANCE**

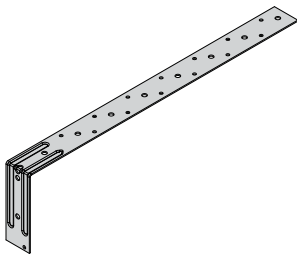

**ST-ST-PFS**  
Page 140

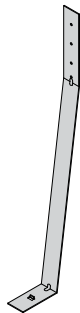

**ST-PFS-50-100-M**  
Page 33



**ST-PFS-50-100**  
Page 33

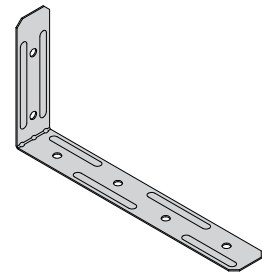

**WBR**  
Page 141

**STAINLESS STEEL**

**MISC**



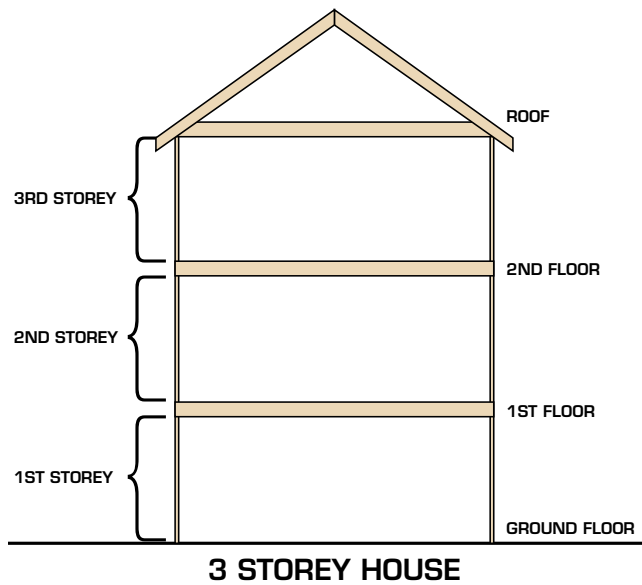

Lateral restraint of the walls can be provided by the roof, the restraint must be provided perpendicular to the roof trusses.

The information we provide has been compiled using the minimum requirement from Building Regulations 2010 approved document A, Scottish Building regulation domestic, NHBC standards and British Standard BS 5628-1;2005 Annex D.

These have been issued as guidance only, the overall responsibility lies with the Building Designer.

## VERTICAL RESTRAINT

### Bent Strap To Wall Plate

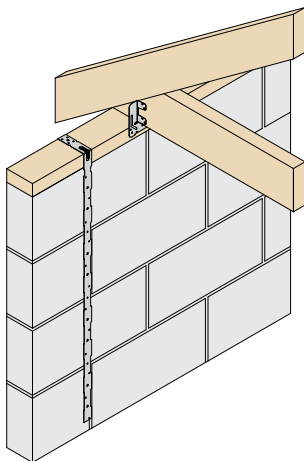

Fix VRS or LDGS to the wall plate with 2No 3.4 x 35mm square twist nails. Fixings into masonry to be specified by building designer.

### Twisted Strap To Truss

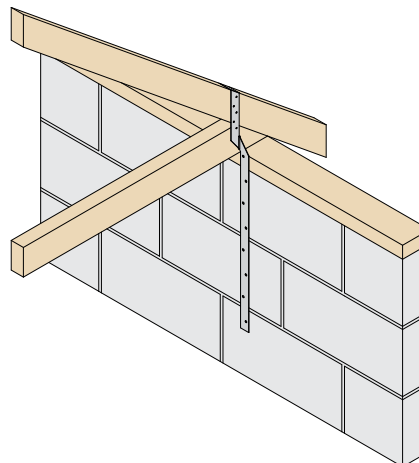

RST strap to be nailed to truss with 3.4 x 35mm square twist nails. Nail quantity dependant on uplift value. Fixings into masonry to be specified by building designer.

## HORIZONTAL RESTRAINT (MASONRY & TIMBER GABLES)

Detail	Region	Floor Level		
		Up to and including 2 storeys	3 storeys	4 storeys
Perpendicular	England & Wales	PFS or HDGS or RST* required at 2m max centres		PFS or HDGS or RST* required at 1.25m max centres
	Scotland	PFS or HDGS or RST* required at 2m max centres	PFS or HDGS or RST* required at 1.25m max centres	

\*For timber gables

- Straps to be installed at not more than 2m centres (or 1.25m where appropriate) along gable end.
- Strap to be of sufficient length to be fixed to a minimum of 3no. Trusses.
- Longitudinal bracing to be fixed to each truss with 2no. 3.35 x 65mm round wire nails (in all details 3.1 x 90mm long mechanically driven nails may be substituted for 3.35 x 65mm long wire nails).
- Where the position of the strap does not coincide with an existing longitudinal truss brace, then the strap may be fixed to an additional 25 x 100mm longitudinal binder (as shown in detail X). The binder to be fixed over a minimum of four trusses and fixed to each truss with 2no. 3.35 x 65mm round wire nails.
- Fix straps to longitudinal bracing with 8no. 3.4 x 35mm square twist nails, evenly spaced along the length of the strap (for NHBC warranted buildings, in accordance with NHBC Standards 2017 section 7.2.8, 8no. 25 x 4mm steel screws shall be used instead of square twist nails).

## HORIZONTAL RESTRAINT (MASONRY GABLES)

### Fixing to Longitudinal Truss Bracing (Fixed to Truss Web)

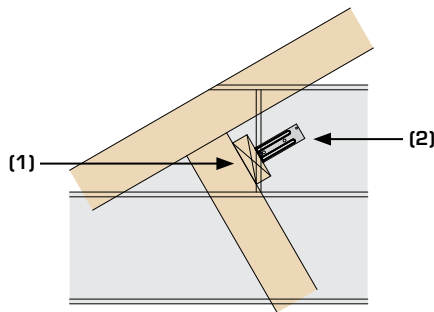

- Install PFS or HDGS on the 25 x 100mm longitudinal truss bracing (1).
- Ensure the position of the longitudinal bracing and strap coincide with the blocks vertical joint.
- The 90deg bend of the strap is to be held tight against the cavity face of the inner leaf of blockwork (2), preferably located on the full block. Notch the blocks to accommodate the angle of the strap and ensure notch is fully mortared.

### Fixing to Longitudinal Truss Bracing / Additional Longitudinal Binder (Fixed to Truss Web)

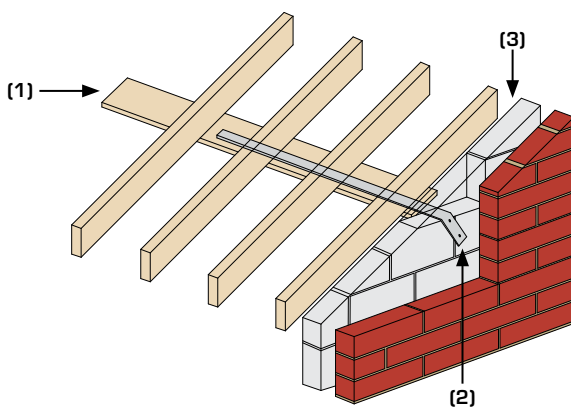

- Install PFS or HDGS on the 25 x 100mm longitudinal truss bracing (1).
- Ensure the position of the longitudinal bracing and strap coincide with a horizontal blockwork joint.
- The 90deg bend of the strap is to be held tight against the cavity face of the inner leaf of blockwork (2), preferably located on a substantial piece of blockwork, i.e. over the centre of a full block, with a single cut block over the strap (3). Notch the blocks to accommodate the angle of the strap and ensure notch is fully mortared.

### Fixing to Solid Noggins (Between Trusses)

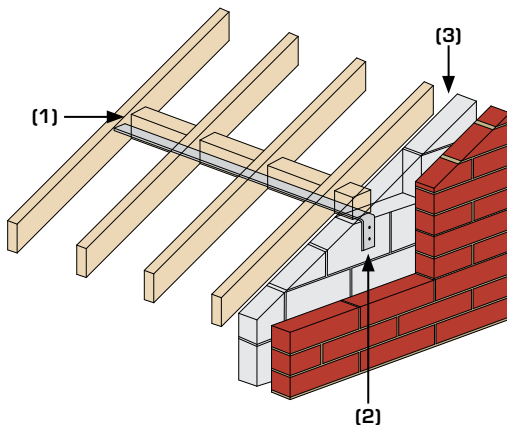

- Ensure the position of the straps coincides with the horizontal blockwork joint.
- Install PFS or HDGS to underside of solid noggins (1). Noggins to be fixed horizontally to avoid twisting of the restraint straps.
- The 90deg bend of the strap is to be held tight against the cavity face of the inner leaf of blockwork (2), preferably located on a substantial piece of blockwork, i.e. over the centre of a full block, with a single cut block over the strap (3). Notch the blocks to accommodate the angle of the strap and ensure notch is fully mortared.
- Fix straps to noggins/trusses with 8no. 3.4 x 35mm square twist nails, evenly spaced along the length of the strap (for NHBC warrantied buildings, in accordance with NHBC Standards 2017 section 7.2.8, 4no. 50 x 4mm steel screws or 4no. 75 x 4mm round wire nails, with one fixing into the third rafter, shall be used instead of square twist nails).

### Fixing to Longitudinal Truss Bracing / Additional Longitudinal Binder (Fixed to Truss Ceiling)

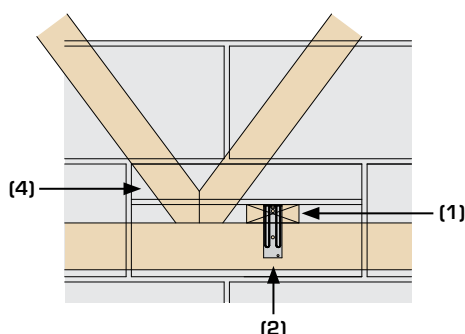

- Install PFS or HDGS on the 25 x 100mm longitudinal truss bracing (1). Bracing to be fixed to each truss with 2no. 3.35 x 65mm round wire nails.
- Ensure the position of the longitudinal bracing and strap coincide with a horizontal blockwork joint, where this is not possible inserted a cut block to suit strap location (4).
- The 90deg bend of the strap is to be held tight against the cavity face of the inner leaf of blockwork (2), preferably located on a substantial piece of blockwork, i.e. over the centre of a full block.

## HORIZONTAL RESTRAINT (TIMBER GABLES)

- Gable panel to be restrained vertical using VRS or LDGS holding down straps at suitable centres.
- External masonry to be connected to gable panel using suitable FT timber frame wall ties.
- Solid blocking required between truss and wall.

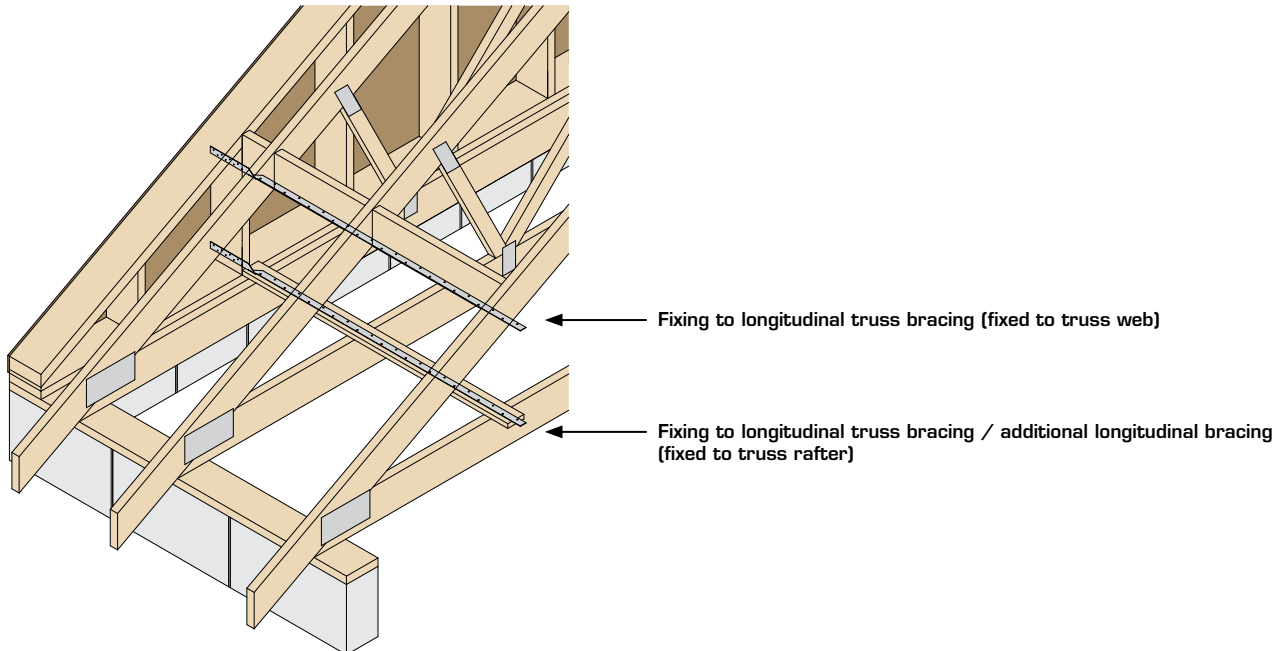

### Fixing to Longitudinal Truss Bracing (Fixed to Truss Web)

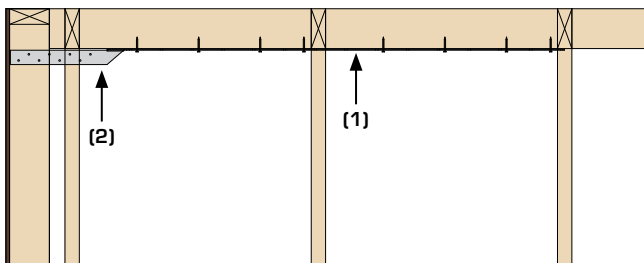

- Install RST-3 to underside of solid noggins (1). Noggins to be fixed horizontally to avoid twisting of the restraint straps.
- Strap to be fixed to face of vertical stud (within gable panel) with 3no. 3.4 x 35mm square twist nails (2).
- Fix straps to noggins/trusses with 8no. 3.4 x 35mm square twist nails, evenly spaced along the length of the strap (for NHBC warrantied buildings, in accordance with NHBC Standards 2017 section 7.2.8, 4no. 50 x 4mm steel screws or 4no. 75 x 4mm round wire nails, with one fixing into the third rafter, shall be used instead of square twist nails).

### Fixing to Longitudinal Truss Bracing / Additional Longitudinal Binder (Fixed to Truss Rafter)

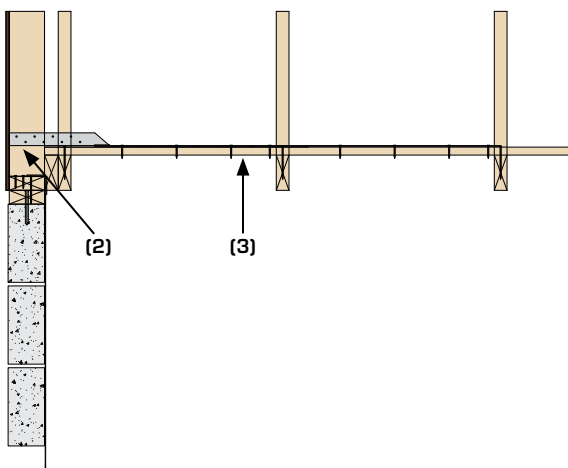

- Install RST-3 on the 25 x 100mm longitudinal truss bracing (3).
- Ensure the position of the longitudinal bracing and strap coincide with vertical timber studs (within gable panel).
- Strap to be fixed to face of vertical stud (within gable panel) with 3no. 3.4 x 35mm square twist nails (2).
- Fix straps to longitudinal bracing with 8no. 3.4 x 35mm square twist nails, evenly spaced along the length of the strap (for NHBC warrantied buildings, in accordance with NHBC Standards 2017 section 7.2.8, 8no. 25 x 4mm steel screws shall be used instead of square twist nails).

# Restraint Straps (Domestic Floors)

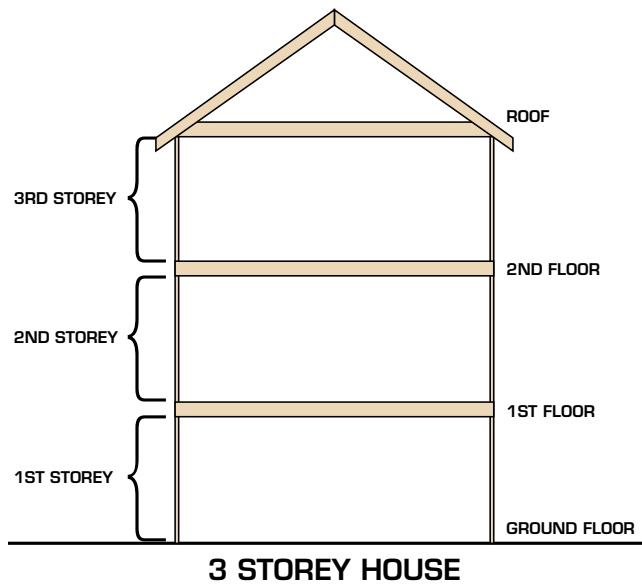

Lateral restraint of the walls can be provided by the floor; the restraint must be provided parallel and perpendicular to the floor joists.

The type of restraint straps required and the centres at which they are placed depend on the joist end detail and region in which the house is built.

The information we provide has been compiled using the minimum requirement from Building Regulations 2010 approved document A, Scottish Building regulation domestic, NHBC standards and British Standard BS 5628-1;2005 Annex D.

These have been issued as guidance only, the overall responsibility lies with the Building Designer.

For 3rd floor and above please refer to the building standards or building designer for guidance.

All straps require a full storey of block work above to achieve the full 8kN declared load capacity.

## PARALLEL RESTRAINT

### PSB strap with built in detail

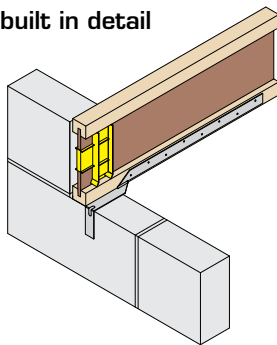

- The strap should be nailed with a minimum of 8No 3.4 x 35mm Square Twist Nails into the joist top flange/chord

Detail	Region	Floor Level		
		Ground Floor	1st Floor	2nd Floor
Built in	England & Wales	Where joists have a minimum bearing of 90mm no additional restraint is required (additional PSB straps required each side of opening where openings exceed 600mm)		PSB straps required at 2m max centres
	Scotland			

Please refer to page 137 for further information on PSB straps

### PST strap with non-restraint hanger

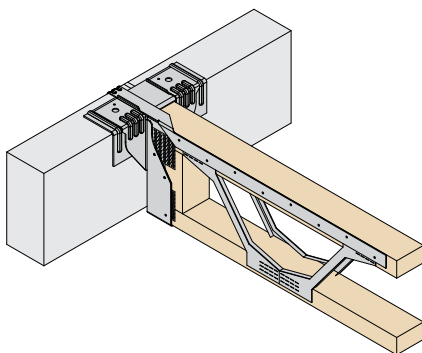

- The strap should be nailed with a minimum of 8No 3.4 x 35mm Square Twist Nails into the joist top flange/chord

Detail	Region	Floor Level		
		Ground Floor	1st Floor	2nd Floor
Non-Restraint Hangers (JHI/JHIR/RB-JHI/RB-JHIR)	England & Wales	PST or PSC required at 2m max centres		
	Scotland	PST or PSC required at 2m max centres	PST or PSC required at 1.25m max centres	

Please refer to page 137 for further information on PST/PSC straps

### PSB strap with restraint hanger

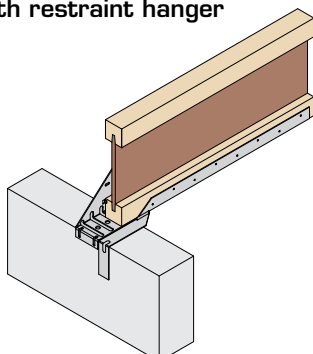

- The strap should be nailed with a minimum of 8No 3.4 x 35mm Square Twist Nails into the joist top flange/chord

Detail	Region	Floor Level		
		Ground Floor	1st Floor	2nd Floor
Restraint Hangers (RA/HRAD/RADS)	England & Wales	No additional restraint is required (additional PSB straps required each side of opening where openings exceed 600mm)		PSB required at 2m max centres
	Scotland	PSB required at 1.25m max centres		

Please refer to page 137 for further information on PSB straps

## PERPENDICULAR RESTRAINT

Detail	Region	Floor Level		
		Ground Floor	1st Floor	2nd Floor
Perpendicular	England & Wales	PFS or HDGS required at 2m max centres		
	Scotland	PFS or HDGS required at 2m max centres		PFS or HDGS required at 1.25m max centres

### PFS surface fixed to I-Joist

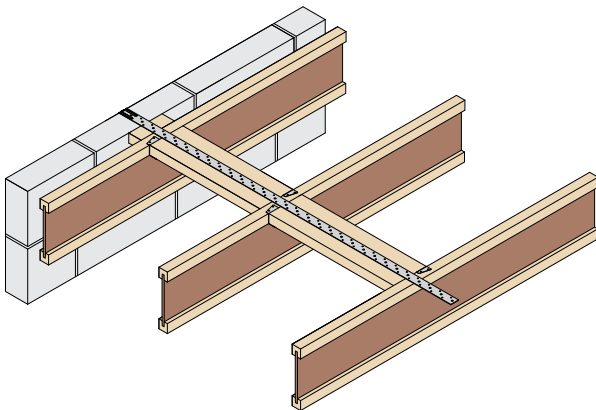

- Noggins to be installed between the I-Joists with 2No UZ Clips staggered either side (Noggins to be minimum half the depth of the joists x depth of flange)
- Once nailed into position a skew nail is placed in the opposite corner to secure connection
- After fitting all noggins the PFS strap can then be located tight to the block work and centred on the noggins
- The strap should be nailed with a minimum of 8No 3.4 x 35mm square twist nails evenly spaced and into at least every joist
- Strap must extend over a minimum 3No joists

### PFS through web of I-Joist

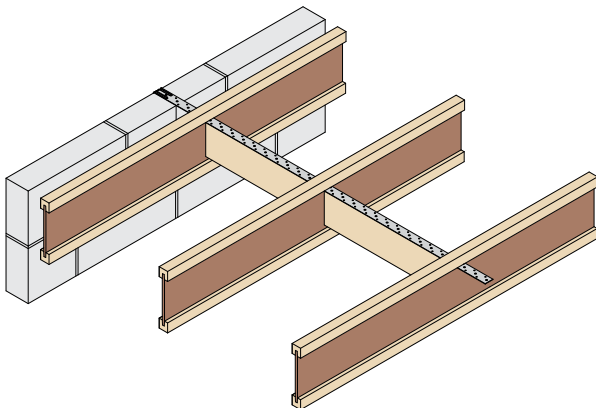

- Cut a small slot in the I-Joist web, just under the top flange
- Slide the PFS through the slots and position tight against the block work
- To provide a fixing for the PFS, noggins must be installed between the I-Joists (Noggins to be at least half the I-Joist depth, to a maximum of 150mm x minimum 38mm wide)
- Each noggin should be nailed in place through the I-Joist web
- The strap should be nailed with a minimum of 8No 3.4 x 35mm square twist nails evenly spaced into the noggins
- Strap must extend over a minimum 3No joists

### PFS through web of Open Web Joist

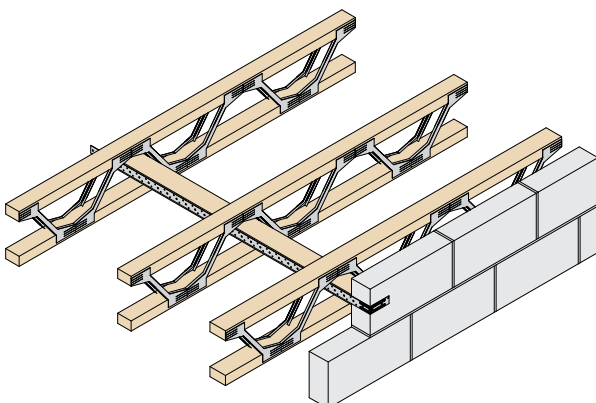

- Strongback to be installed as per manufacturer's guidelines
- Position PFS tight to block work and centred on block
- The strap should be nailed with a minimum of 8No 3.4 x 35mm square twist nails evenly spaced into the noggins
- Strap must extend over a minimum 3No joists

## Vertical Restraint Strap



The VRS is an engineered strap that has been designed to provide a convenient and secure method of fixing wall plates to timber and masonry walls.

### Features & Benefits

- Designed to provide optimum performance
- Thinner profile than a standard tie-down strap with strengthening ribs, achieving the same performance as a traditional 30 x 2.5mm strap

### Material Specification

- 30 x 1.2mm Galvanised mild steel - Z600

### Approvals

- CE marked and tested in accordance with EN846-4
- Meets NHBC Technical requirements

### Fixings

Dependant on application.

### Dimensions (mm)

4mm Ø and 6mm Ø holes

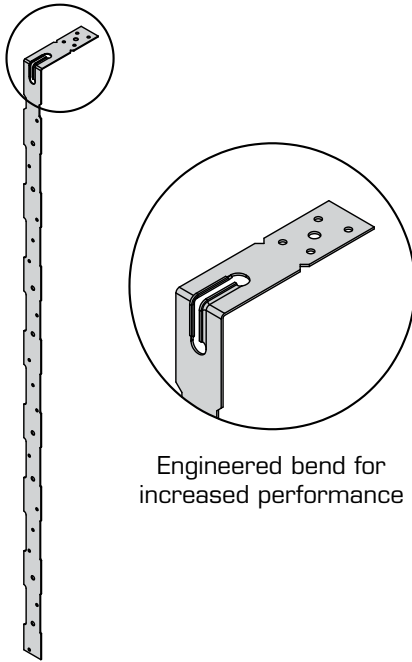

Engineered bend for increased performance

### Available Sizes

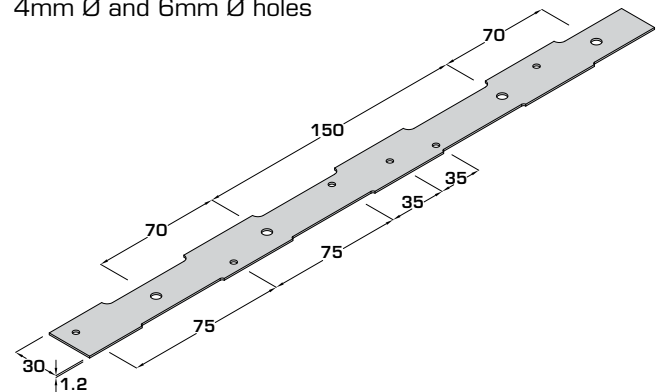
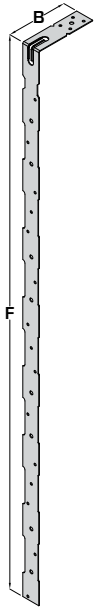

Product Code	F (mm)	B (mm)
VRS-900-100	900	100

### Load Data

Performance	Fixings (3.4 x 35mm)			Characteristic Tensile Capacity (kN)
	Wall Plate (3.4 x 35mm)	Timber Stud (3.4 x 35mm)	Wall (#8/6mm Nylong Plugs)	
Fixed to 3.5N/mm <sup>2</sup> block work & nailed to min C16 grade timber wall plate*	2	n/a	6*	4.80
Nailed to timber stud & wall plate (min C16 grade)	2	8	n/a	4.80

\*Fixings to be specified by building designer

## Restraint Strap Twist

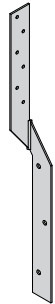

RST-1



RST-2



RST-3

The RST is a high performance strap which can be used to resist uplift.

### Features & Benefits

- Unique geometry allows a fixing on two planes without the clash issues of standard twist straps
- Suitable for timber frame and masonry walls
- Can be used independently or in addition to truss clips/framing anchors/hangers
- Also a suitable strap for providing lateral restraint to timber gables (see page 131)

### Material Specification

- 30 x 1.2mm Galvanised mild steel - Z275

### Fixings

To be specified by building designer

### Dimensions (mm)

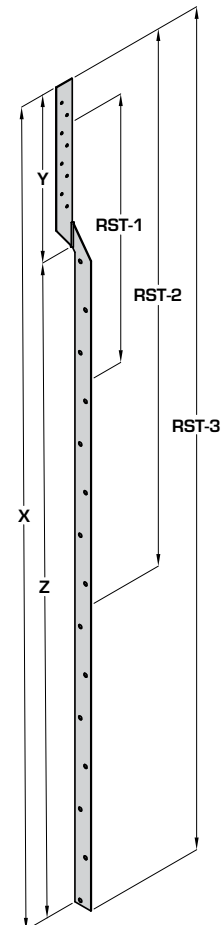

### Available Sizes

Product Code	Dimensions (mm)		
	X	Y	Z
RST-1	405	205	200
RST-2	848	275	573
RST-3	1350	275	1075

Product Code	Fixing Hole Qty	
	4mm Ø	6mm Ø
	Y	Z
RST-1	6	3
RST-2	8	8
RST-3	8	15

### Load Data

Performance	Tensile Capacity (kN)	Characteristic Tensile Capacity (kN)
Strap only	7.50	11.80

## Pre Formed Strap



The **PFS** is an engineered strap that has been designed to provide enhanced performance and greater flexibility of use.

### Features & Benefits

- Typically used for lateral restraint in floor and roof applications
- Exceeds performance of traditional 30 x 5mm strap

### Material Specification

- 35 x 1.5mm Galvanised mild steel - Z600 or Z275 (with edge protection)

### Approvals

- CE marked and tested in accordance with EN846-4
- Meets NHBC Technical requirements
- Meets Homebond technical requirements

### Fixings

Dependant on application

Code	Description	Box Qty
547389	3.4 x 35mm Square Twist Nails - LOOSE	500
141185	3.4 x 35mm Square Twist Nails - COLLATED*	2,500

\*For use with Paslode PPN35Ci

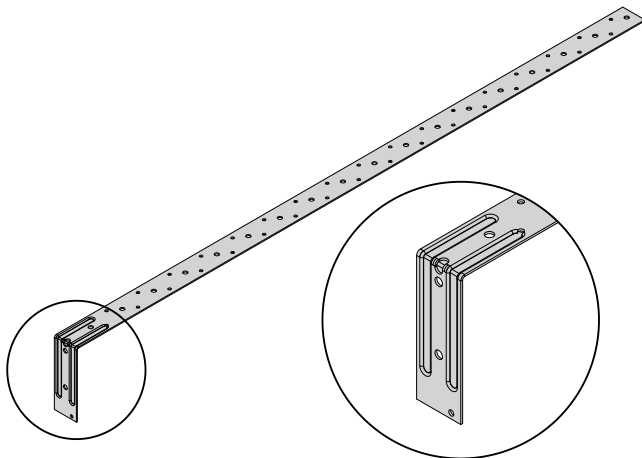

Engineered bend for increased performance

### Available Sizes

#### FLAT STRAP

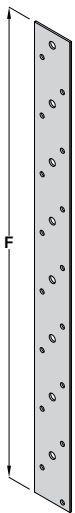

#### BENT STRAP

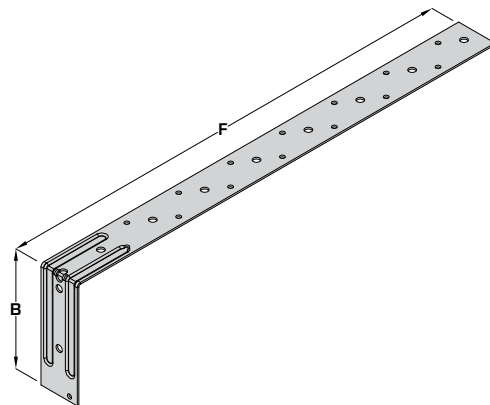

### Dimensions (mm)

4mm Ø and 6mm Ø holes

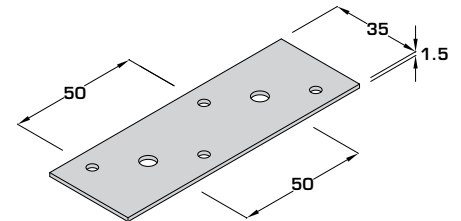

Product Code	F (mm)
PFS-1000-F	1000
PFS-1200-F	1200
PFS-1600-F	1600
PFS-2000-F	2000

Product Code	F (mm)	B (mm)
PFS-900-100-B	900	100
PFS-1100-100-B	1100	100
PFS-1500-100-B	1500	100
PFS-1900-100-B	1900	100

### Load Data

Performance	Fixings	Characteristic Tensile Capacity (kN)
	(3.4 x 35mm)	
Built into 3.5N/mm <sup>2</sup> block work & nailed to min C16 grade timber**	BN0	8.80
Flat Strap	n/a	10.80

\*\*Full storey of block work required above the strap to meet performance.



# PS RANGE



## Pre Formed Strap



The **PS** range provides required parallel restraint to block work for joist hangers and, where required, build-in details.

### Features & Benefits

- Typically used for lateral restraint
- Straps suit various blockwork sizes

### Material Specification

- 30 x 2mm Galvanised mild steel - Z600

### Approvals

- CE marked and tested in accordance with EN846-4
- Meets NHBC Technical requirements

### Fixings

Code	Description	Box Qty
547389	3.4 x 35mm Square Twist Nails - LOOSE	500
141185	3.4 x 35mm Square Twist Nails - COLLATED*	2,500

\*For use with Paslode PPN35Ci

### Dimensions (mm)

4mm Ø holes

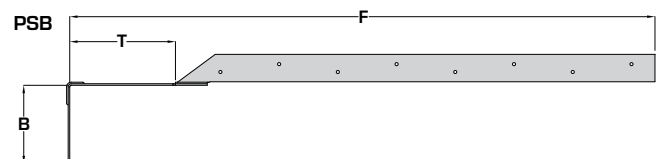
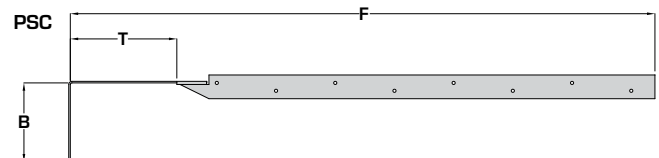
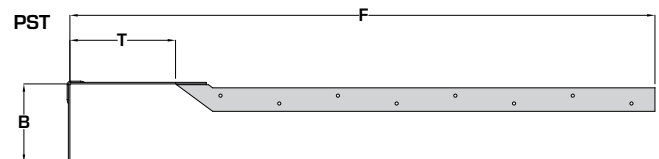

### Available Sizes

Product Code	Minimum Block Work Width (mm)	Maximum Block Work Width (mm)	B (mm)	F (mm)	T (mm)
PST-135	100	125	100	747	135
PST-220	140	215	100	840	220
PSC-135	100	125	100	740	135
PSC-220	140	215	100	825	220
PSB	n/a	n/a	100	747	135

Please refer to page 132 for guidance on strap requirement

### Strap Selection

Hanger Depth	I-Joist Depth (mm)					
	195/200	220	240	300	350/360	400
195	PST					
225		PST	PSC			
240			PST			
250						
300				PST		
350					PST	
400						PST

Hanger Depth	Open Web Joist Depth (mm)					
	195/202	219/230	253/254	304	375/380	418/424
195	PST					
225		PST	PSC			
240			PST			
250			PST			
300				PST		
350					PSC	
400						PSC

### Load Data

Performance	Fixings	Characteristic Tensile Capacity (kN)
	(3.4 x 35mm)	
Built into 3.5N/mm <sup>2</sup> block work & nailed to min C16 grade timber**	8No	8.00

\*\*Full storey of block work required above the strap to meet performance.



## Light Duty Galvanised Strap

The **LDGS** is a light duty traditional strap.

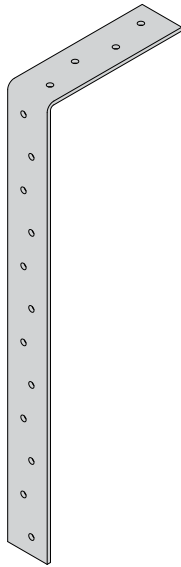

### Features & Benefits

- Typically used for vertical restraint

### Material Specification

- 30 x 2.5mm Galvanised mild steel - Z275

### Fixings

To be specified by building designer

### Dimensions (mm)

6mm Ø holes spaced at 25mm centres

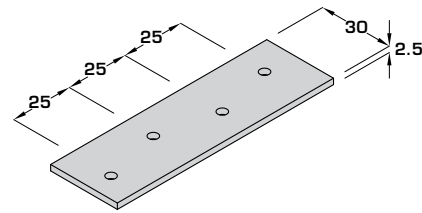

### Available Sizes

#### FLAT STRAP

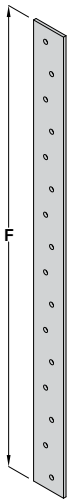

#### BENT STRAP

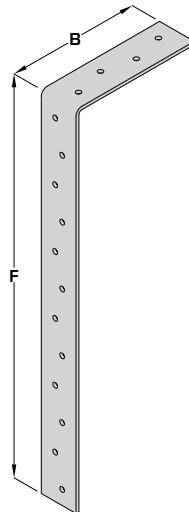

#### TWIST STRAP

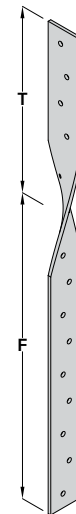

Product Code	F (mm)
LDGS-200-F	200
LDGS-300-F	300
LDGS-400-F	400
LDGS-600-F	600
LDGS-800-F	800
LDGS-900-F	900
LDGS-1000-F	1000
LDGS-1200-F	1200
LDGS-1600-F	1600
LDGS-2000-F	2000

Product Code	F (mm)	B (mm)
LDGS-200-100-B	200	100
LDGS-250-100-B	250	100
LDGS-300-100-B	300	100
LDGS-500-100-B	500	100
LDGS-800-100-B	800	100
LDGS-900-100-B	900	100
LDGS-1100-100-B	1100	100
LDGS-1300-100-B	1300	100
LDGS-1500-100-B	1500	100
LDGS-1900-100-B	1900	100

Product Code	F (mm)	T (mm)
LDGS-500-100-T	500	100
LDGS-800-100-T	800	100
LDGS-900-100-T	900	100
LDGS-1100-100-T	1100	100

### Load Data

Performance	Fixings	Characteristic Tensile Capacity (kN)
	(3.4 x 35mm)	
Fixed timber wall plate (min C16 grade timber)*	2	2.80
Flat Strap	n/a	17.28

\*Full storey of block work required above the strap to meet performance.

## Heavy Duty Galvanised Strap

The HDGS is a heavy duty traditional strap.

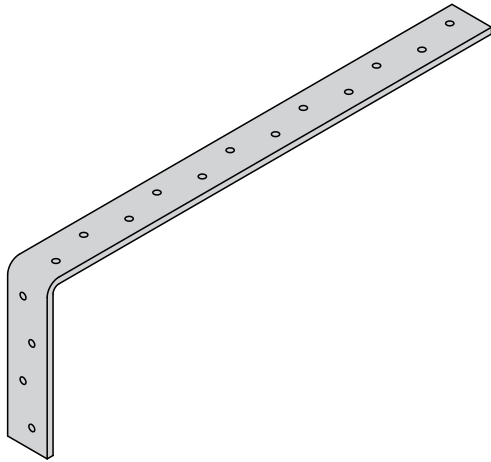

### Features & Benefits

- Typically used for lateral restraint.

### Material Specification

- 27 x 4mm Galvanised mild steel - Z275

### Fixings

To be specified by building designer

### Dimensions (mm)

6mm Ø holes spaced at 25mm centres

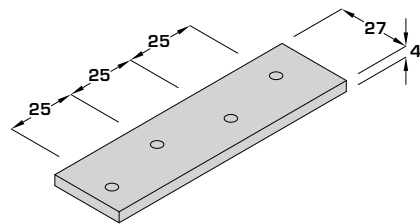

### Available Sizes

#### FLAT STRAP

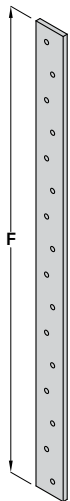

Product Code	F (mm)
HDGS-450-F	450
HDGS-600-F	600
HDGS-900-F	900
HDGS-1000-F	1000
HDGS-1200-F	1200
HDGS-1500-F	1500
HDGS-1600-F	1600
HDGS-2000-F	2000

#### BENT STRAP

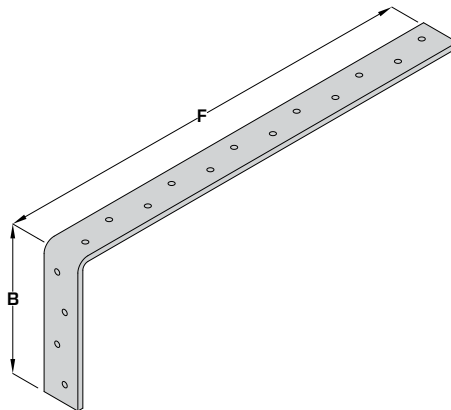

Product Code	F (mm)	B (mm)
HDGS-500-100-B	500	100
HDGS-800-100-B	800	100
HDGS-900-100-B	900	100
HDGS-1100-100-B	1100	100
HDGS-1200-100-B	1200	100
HDGS-1450-150-B	1450	150
HDGS-1500-100-B	1500	100
HDGS-1900-100-B	1900	100

#### TWIST STRAP

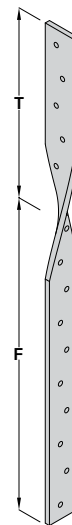

Product Code	F (mm)	B (mm)
HDGS-800-100-T	800	100

### Load Data

Provides a minimum load requirement of 8kN per strap at 2m centres to meet BS EN845-1

Performance	Fixings	Characteristic Tensile Capacity (kN)
	(3.4 x 35mm)	
Built into 3.5N/mm <sup>2</sup> block work & nailed to min C16 grade timber*	8No	10.5
Flat Strap	n/a	25.2

\*Full storey of block work required above the strap to meet performance.

# ST-ST-PFS



## Stainless Steel Pre Formed Strap

The **ST-ST-PFS** is an engineered stainless steel strap.

### Features & Benefits

- Stainless steel allows for varied applications

### Material Specification

- 35 x 1.2mm Austenitic Stainless Steel

### Fixings

To be specified by building designer

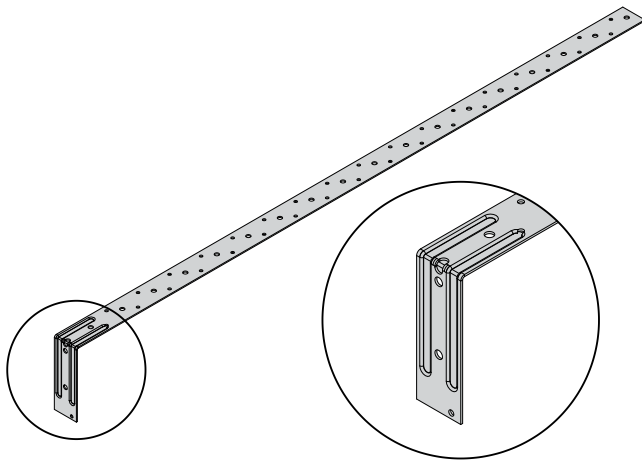

### Available Sizes

#### FLAT STRAP

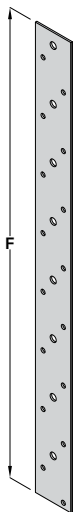

Product Code	F (mm)
ST-ST-PFS-600-F	600
ST-ST-PFS-1000-F	1000
ST-ST-PFS-1200-F	1200
ST-ST-PFS-1300-F	1300
ST-ST-PFS-2000-F	2000

#### BENT STRAP

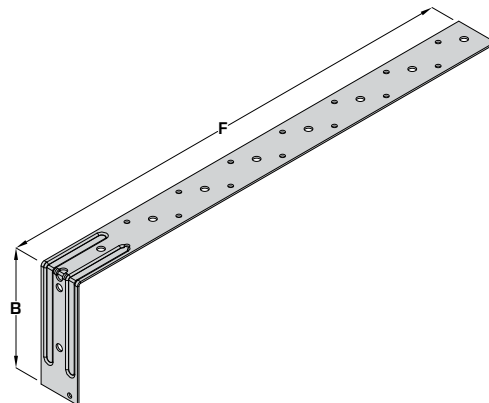

Product Code	F (mm)	B (mm)
ST-ST-PFS-900-100-B	900	100
ST-ST-PFS-1100-100-B	1100	100
ST-ST-PFS-1500-100-B	1500	100
ST-ST-PFS-1900-100-B	1900	100

### Dimensions (mm)

4mm Ø and 6mm Ø holes

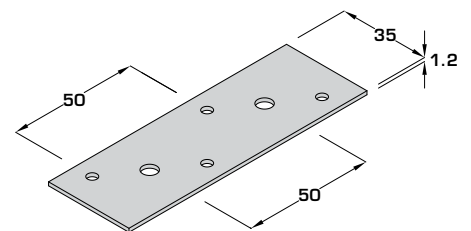

## Window Bracket

The WBR window bracket attaches timber window boards to the internal face of a masonry wall.

### Features & Benefits

- Specially designed solution to a common application

### Material Specification

- 30 x 1mm Galvanised mild steel - Z275

### Fixings

To be specified by building designer

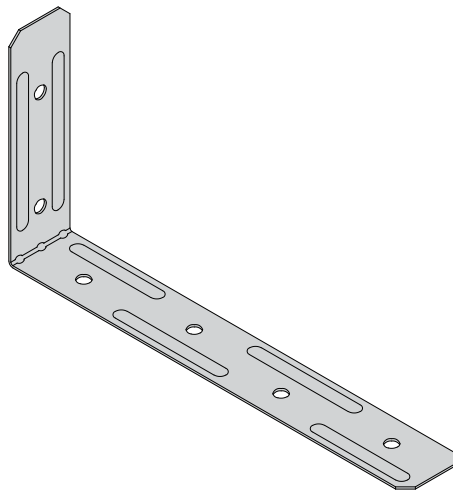

### Available Sizes

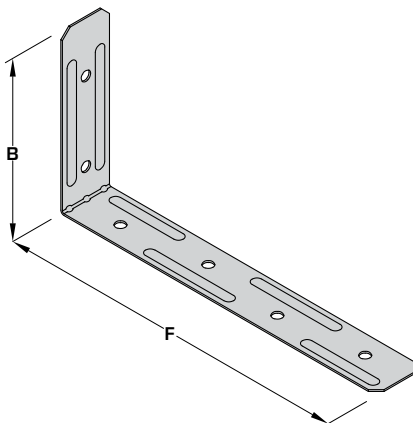

Product Code	F (mm)	B (mm)
WBR	200	100

### Dimensions (mm)

6mm Ø holes

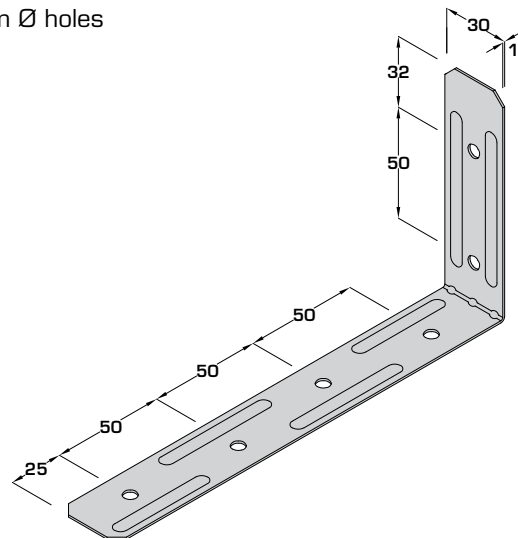

### In Situ

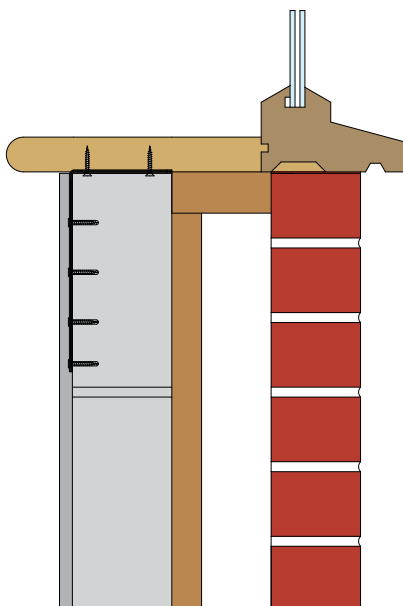





# Product Range Index



	<b>Page</b>		<b>Page</b>
<b>45L/R</b> Face Fix 45° Hanger (EWP)	89	<b>PSTS</b> Paslode Structural Screw (EWP)	96 - 100
<b>45L/R</b> Face Fix 45° Hanger (Solid Timber/Roof Truss)	117	<b>PSTS</b> Paslode Structural Screw (Timber Frame)	38
<b>ACE</b> Adjustable Connector Eaves	88	<b>PWS</b> Party Wall Strap	37
<b>AWS</b> Acoustic Wall Strap	36	<b>RA RANGE</b> Restraint Angle Range	26 - 29
<b>FAS</b> Framing Anchor	127	<b>RB-JHI</b> Rapid Build Masonry Joist Hanger	18 - 19
<b>FFI</b> Face Fix I-Joist Hanger	63 - 66	<b>RD-CDCR</b> Corner Disproportionate Collapse Restraint	42
<b>FMHI</b> Flexible Masonry Hanger	20 - 22	<b>RD-DCR</b> Disproportionate Collapse Restraint	40
<b>FT</b> Timber Frame / SIPs Wall Tie	44	<b>RD-HDCR</b> Heavy Disproportionate Collapse Restraint	41
<b>FTHI</b> Flexible Timber Hanger (EWP)	83	<b>RST</b> Restraint Strap Twist	135
<b>FTHI</b> Flexible Timber Hanger (Solid Timber/Roof Truss)	114	<b>SA-45</b> Skewed Angle 45° Hanger	116
<b>HDGS</b> Heavy Duty Galvanised Strap	139	<b>SB</b> Support Bracket	121
<b>HGG</b> Heavy Girder To Girder	108	<b>SB-JHIR</b> Safe Build Masonry Joist Hanger	16 - 17
<b>HMH</b> Heavy Multi Hanger	107	<b>SHI</b> Service Hole I-Joist	101
<b>HMT</b> High Movement Timber Frame Wall Tie	45	<b>SP</b> Sole Plate Anchor	34
<b>HUH</b> Heavy Universal Hanger (I-Joist)	67 - 70	<b>SS</b> Slide Shoe	126
<b>HUH</b> Heavy Universal Hanger (Open Web)	71 - 77	<b>ST-ST-PFS</b> Stainless Steel Pre Formed Strap	140
<b>HV-GR</b> Hi-Vis Gripper	30 - 31	<b>ST-PFS/ST-PFS-M</b> Timber Frame Holding Down Strap	33
<b>I-Clip</b> Multiple I-Joist Connector	92 - 93	<b>TA</b> Truss Anchor	124
<b>IR-CLIP</b> Insulation Retaining Clip	35	<b>TA-1</b> Framing Anchor	125
<b>JHI</b> Masonry Joist Hanger	16 - 17	<b>TC</b> Truss Clip	123
<b>KH</b> Kwiki Hanger Standard Leg	110	<b>TM</b> Midi Shoe	105
<b>KHL</b> Kwiki Hanger Long Leg	111	<b>TS</b> Truss Shoe	106
<b>KM</b> Mini Hanger (EWP)	82	<b>UH</b> Universal Hanger (I-Joist)	49 - 56
<b>KM</b> Mini Hanger (Solid Timber/Roof Truss)	104	<b>UH</b> Universal Hanger (Open Web)	57 - 62
<b>LAB</b> Angle Bracket	115	<b>UZ-Clip</b> Noggin Support	90 - 91
<b>LDGS</b> Light Duty Galvanised Strap	138	<b>VHGG</b> Very Heavy Girder To Girder	109
<b>MH RANGE</b> Multi Hanger (EWP)	80 - 81	<b>VRC</b> Variable Ridge Connector	86 - 87
<b>MH RANGE</b> Multi Hanger (Solid Timber/Roof Truss)	112 - 113	<b>VRS</b> Vertical Restraint Strap	134
<b>M-STD/M-RTN</b> Very High Load Masonry Hanger	23	<b>VS</b> Variable Skewed Timber Hanger (EWP)	84 - 85
<b>NP</b> Nail Plate	120	<b>VS</b> Variable Skewed Timber Hanger (Solid Timber)	118 - 119
<b>OW-Clip</b> Multiple Joist Connector	94 - 95	<b>VSM</b> Variable Skew Masonry Hanger	24 - 25
<b>PFS</b> Pre Formed Strap	136	<b>WBR</b> Window Bracket	141
<b>PS RANGE</b> Pre Formed Strap	137		



The information given in this document is believed to be current and accurate as at the date of publication. As part of our continuous product development, we reserve the right to revise specifications without notice.

**Copyright © 2017 ITW**

All rights reserved. This document (including text, material, pictures, specifications and dimensions contained in it) may not be reproduced, transmitted or distributed or otherwise used in any way or by any means, except with the prior express permission of ITW Construction Products.



### Customer Services

ITW Construction Products  
1 Wheatstone Place  
Southfield Industrial Estate  
Glenrothes  
Fife  
KY6 2SW  
United Kingdom

t : +44 (0) 1592 771132  
f : +44 (0) 1592 771182  
e : orders@itwcp.com

### Cullen Technical Support

t : +44 (0) 1592 777570  
f : +44 (0) 1592 777575  
e : cullentechnical@itwcp.com

© ITW Construction Products  
No part of this publication may be reproduced  
without prior permission from ITWCP.

ITW Construction Products - division of ITW Ltd.

[www.itwcp.com](http://www.itwcp.com)

